

# Heat Treatment of Gears

---

A Practical Guide for Engineers

**A.K. Rakhit**



ASM International®  
Materials Park, OH 44073-0002  
[www.asminternational.org](http://www.asminternational.org)

Copyright © 2000  
by  
ASM International®  
All rights reserved

No part of this book may be reproduced, stored in a retrieval system, or transmitted, in any form or by any means, electronic, mechanical, photocopying, recording, or otherwise, without the written permission of the copyright owner.

First printing, December 2000

Great care is taken in the compilation and production of this book, but it should be made clear that NO WARRANTIES, EXPRESS OR IMPLIED, INCLUDING, WITHOUT LIMITATION, WARRANTIES OF MERCHANTABILITY OR FITNESS FOR A PARTICULAR PURPOSE, ARE GIVEN IN CONNECTION WITH THIS PUBLICATION. Although this information is believed to be accurate by ASM, ASM cannot guarantee that favorable results will be obtained from the use of this publication alone. This publication is intended for use by persons having technical skill, at their sole discretion and risk. Since the conditions of product or material use are outside of ASM's control, ASM assumes no liability or obligation in connection with any use of this information. No claim of any kind, whether as to products or information in this publication, and whether or not based on negligence, shall be greater in amount than the purchase price of this product or publication in respect of which damages are claimed. THE REMEDY HEREBY PROVIDED SHALL BE THE EXCLUSIVE AND SOLE REMEDY OF BUYER, AND IN NO EVENT SHALL EITHER PARTY BE LIABLE FOR SPECIAL, INDIRECT OR CONSEQUENTIAL DAMAGES WHETHER OR NOT CAUSED BY OR RESULTING FROM THE NEGLIGENCE OF SUCH PARTY. As with any material, evaluation of the material under end-use conditions prior to specification is essential. Therefore, specific testing under actual conditions is recommended.

Nothing contained in this book shall be construed as a grant of any right of manufacture, sale, use, or reproduction, in connection with any method, process, apparatus, product, composition, or system, whether or not covered by letters patent, copyright, or trademark, and nothing contained in this book shall be construed as a defense against any alleged infringement of letters patent, copyright, or trademark, or as a defense against liability for such infringement.

Comments, criticisms, and suggestions are invited, and should be forwarded to ASM International.

*ASM International staff who worked on this project included Veronica Flint, Manager, Book Acquisitions; Bonnie Sanders, Manager, Production; Carol Terman, Copy Editor; Kathy Dragolich, Production Supervisor; and Scott Henry, Assistant Director, Reference Publications.*

Library of Congress Cataloging-in-Publication Data

Rakhit, A.K.  
Heat treatment of gears / A.K. Rakhit.  
p. cm.  
Includes bibliographical references and index.  
1. Gearing—Heat Treatment. I. ASM International. II. Title.  
TJ184.R35 2000 621.8'33—dc21 00-059341

ISBN: 0-87170-694-6  
SAN: 204-7586

**ASM International®**  
Materials Park, OH 44073-0002  
www.asminternational.org

Printed in the United States of America

This book is dedicated to my parents, Mr. and Mrs. Upendra C. Rakhit; my wife, Ratna, for her understanding and inspiration; and my son, Amit, and daughter, Roma, for their love and support.

---

---

# ASM International Technical Books Committee (1999–2000)

**Sunniva R. Collins (Chair)**

Swagelok/Nupro Company

**Eugen Abramovici**

Bombardier Aerospace (Canadair)

**A.S. Brar**

Seagate Technology Inc.

**Ngai Mun Chow**

Det Norske Veritas Pte Ltd.

**Seetharama C. Deevi**

Philip Morris, USA

**Bradley J. Diak**

Queen's University

**James C. Foley**

Ames Laboratory

**Dov B. Goldman**

Precision World Products

**James F.R. Grochmal**

Metallurgical Perspectives

**Nguyen P. Hung**

Nanyang Technological University

**Serope Kalpakjian**

Illinois Institute of Technology

**Gordon Lippa**

North Star Casteel

**Jacques Masounave**

Université du Québec

**Charles A. Parker, FASM (Vice  
Chair)**

AlliedSignal Aircraft Landing  
Systems

**K. Bhanu Sankara Rao**

Indira Gandhi Centre for Atomic  
Research

**Mel M. Schwartz**

Sikorsky Aircraft Corporation  
(retired)

**Peter F. Timmins**

University College of the Fraser  
Valley

**George F. Vander Voort**

Buehler Ltd.

---

---

# Contents

<b>Preface</b> .....	<b>x</b>
<b>CHAPTER 1: Introduction to Gear Heat Treatment</b> .....	<b>1</b>
<b>CHAPTER 2: Properties of Iron</b> .....	<b>5</b>
Alloys of Iron and Carbon .....	7
Transformation (Decomposition) of Austenite .....	10
<b>CHAPTER 3: Heat Treatment of Gears</b> .....	<b>17</b>
Major Heat Treat Processes .....	18
<b>CHAPTER 4: Through-Hardening Gears</b> .....	<b>21</b>
Through-Hardening Processes .....	22
Some Hints on Through-Hardened Gear Design .....	24
Hardness Measurement .....	25
Heat Treat Distortion of Through-Hardened Gears .....	25
Applications .....	26
Case History: Design and Manufacture of a Rack .....	27
Material Selection .....	27
Process Selection .....	29
<b>CHAPTER 5: Carburizing and Hardening Gears</b> .....	<b>33</b>
Gas Carburizing .....	34
Carburizing Temperature .....	34
Furnaces and Equipment for Gas Carburizing .....	36
Hardening .....	37
Direct Quenching .....	38
Reheating of Carburized Gears and Quenching .....	39
Surface Hardness Variations after Quenching .....	40
Tempering of Carburized and Quenched Gears .....	40
Recarburizing .....	42
Cold Treatment .....	43
Selection of Materials for Carburized Gears .....	44
Hardness and Hardenability .....	45
Carbon Content and Case Property .....	50
Core Hardness of Gear Teeth .....	62
Microstructure of Carburized Cases .....	68
Some Carburizing Problems .....	68

Heat Treat Distortion of Carburized and Hardened Gears . . . . .	76
Mechanics of Heat Treat Distortion . . . . .	77
Material and Heat Treat Process Factors . . . . .	77
Vacuum-Melted versus Air-Melted Alloy Steels . . . . .	81
Measurement of Gear Distortions . . . . .	85
Some Recommendations to Minimize Distortion . . . . .	86
Preheating of Gears . . . . .	90
Distortion Characteristics of Some Gear Materials . . . . .	90
Improvement in Gear Design to Control Heat Treat Distortion . . . . .	91
Grinding Stock Allowance on Tooth Flanks to Compensate for Distortion . . . . .	100
Grinding of Distorted Gears . . . . .	101
Actual Stock Removal and Tooth Surface Hardness . . . . .	103
New Pitting Life . . . . .	105
Distortion Derating Factor . . . . .	107
Side Effects of Grinding Carburized and Hardened Gears . . . . .	108
Shot Peening of Carburized and Hardened Gears . . . . .	111
Heat Treat Characteristics of Two Commonly Used Gear Materials: AISI 4320 and 9310 . . . . .	121
Carburizing Cost . . . . .	122
Applications . . . . .	123
Case History: Distortion Control of Carburized and Hardened Gears . . . . .	123
New Heat Treat Facilities . . . . .	124
Tests . . . . .	125
Conclusions . . . . .	131
<b>CHAPTER 6: Nitriding Gears . . . . .</b>	<b>133</b>
Gas Nitriding Process . . . . .	133
Recommended Tip and Edge Radii of Teeth . . . . .	137
White Layer in Nitrided Gears . . . . .	137
General Recommendations of Nitrided Gears . . . . .	140
Microstructure of Nitrided Cases and Cores . . . . .	141
Overload and Fatigue Damage of Nitrided Gears . . . . .	143
Bending-Fatigue Life of Nitrided Gears . . . . .	144
Nitriding Cost . . . . .	145
Distortion in Nitriding . . . . .	145
European Nitriding Steels . . . . .	146
Applications . . . . .	147
Case History A: Nitriding . . . . .	148
Case History B: Failure of Nitrided Gears . . . . .	152
<b>CHAPTER 7: Modern Nitriding Processes . . . . .</b>	<b>159</b>
Ion/Plasma Nitriding Gears . . . . .	159

Case History: Application of Ion Nitriding to an Internal Ring Gear at an Epicyclic Gear Box . . . . .	164
<b>CHAPTER 8: Carbonitriding Gears . . . . .</b>	<b>171</b>
Case Depth in Carbonitriding . . . . .	172
Measurement of Case Depth . . . . .	172
Materials . . . . .	172
Distortion . . . . .	172
Applications . . . . .	173
<b>CHAPTER 9: Induction Hardening Gears . . . . .</b>	<b>175</b>
Materials . . . . .	176
Pre-Heat Treatment . . . . .	176
Hardening Patterns . . . . .	176
Heating with Induction . . . . .	177
Quenching . . . . .	178
Tempering . . . . .	178
Surface Hardness and Case Depth . . . . .	178
Induction Hardening Problems . . . . .	180
Applications . . . . .	182
Recent Advancements in Induction Hardening . . . . .	182
Dual-Frequency Process . . . . .	182
Flame Hardening . . . . .	184
<b>CHAPTER 10: Selection of Heat Treat Process for Optimum Gear Design . . . . .</b>	<b>185</b>
Materials Selection . . . . .	185
Gear Design Feature . . . . .	187
General Conclusions . . . . .	188
<b>CHAPTER 11: Selected References . . . . .</b>	<b>189</b>
<b>Index . . . . .</b>	<b>193</b>

---

---

# Preface

At the beginning of my career in gear design and manufacturing, I experienced a great deal of difficulty learning the art of gear heat treatment. I struggled a lot, attended a number of seminars on the subject, and spent a great deal of time experimenting with gear heat treatment. Over the last 50 years, a great deal of research has been carried out and published in the disciplines. Unfortunately, very little has been published on heat treatment of gears that is both easy to understand and useful to the gear engineer. This book has been specially written for the benefit of gear engineers engaged in design and manufacturing because I thought it would be beneficial to share my experience with the gear engineers of the future. I believe the information presented in this book will give them a good start in their careers.

Gears have been in existence for a long time. Before the invention of steel, gears were made of materials that were readily available and easily machinable, such as wood. Obviously, these gears did not last long and required frequent replacement. Cost was not as important as it is now.

Today there is continual demand for gear designs that transmit more power through smaller, lighter, quieter, and more reliable packages that must operate over a wide range of service conditions, with an increased emphasis on cost containment. The average life requirement for a gear in industrial service is now measured in millions of cycles. These requirements have accelerated the development and use of high-strength materials. Gears made of certain steels are found to meet these demands and to become especially effective when they are heat treated and finish machined for high geometric accuracy. This makes gear design and manufacturing more complex. In order to perform these tasks efficiently, a gear engineer needs to excel in various other disciplines besides design, such as manufacturing, lubrication, life and failure analysis, and machine dynamics.

Designing gears is a process of synthesis where gear size and geometry, materials, machining processes, and heat treatment are selected to meet the expected level of quality in the finished gears. These considerations are critical if the gears are to perform satisfactorily under anticipated service conditions. This led to the development of various design guidelines for an optimum gear set. However, in my opinion, the quality of gear heat treatment and its effect on gear performance and related cost are still not addressed.



In this book, I discuss gear heat treat distortion for the major heat processes in detail because my experience is that distortion of gears after heat treatment always presents difficulty in minimizing manufacturing cost. Hence, distortion control offers a challenging opportunity to a gear engineer not only in ensuring a high-quality product but also in controlling cost. A case history of each successful gear heat treat process is included. These case histories will provide important information on the quality of gear that can be expected with proper control of material and processes. This information will be beneficial not only in understanding distortion, but also in the selection of the proper gear material and appropriate heat treat process for a wide range of applications.

Writing a book takes a great deal of support and cooperation from many people. I wish to acknowledge all those who helped me with this project, with special thanks to Solar Turbines, Inc; to Mr. Bruce Kravitz of Kravitz Communications for proofreading and making many valuable editorial suggestions; and to Mrs. Sharon Jackson of Solar Turbines Inc., for typing the manuscript. I am also very grateful to Mr. Darle W. Dudley of Dudley Technical Group, Inc. for his guidance and encouragement with this project.

Finally, I would like to thank my many colleagues at the various gear manufacturing organizations with which I am associated for their help and inspiration.

A.K. Rakhit  
June 2000



The Materials  
Information Society

**ASM International** is the society for materials engineers and scientists, a worldwide network dedicated to advancing industry, technology, and applications of metals and materials.

ASM International, Materials Park, Ohio, USA  
www.asminternational.org

This publication is copyright © ASM International®. All rights reserved.

Publication title	Product code
<b>Heat Treatment of Gears: A Practical Guide for Engineers</b>	<b>#06732G</b>

**To order products from ASM International:**

**Online** Visit [www.asminternational.org/bookstore](http://www.asminternational.org/bookstore)

**Telephone** 1-800-336-5152 (US) or 1-440-338-5151 (Outside US)

**Fax** 1-440-338-4634

**Mail** Customer Service, ASM International  
9639 Kinsman Rd, Materials Park, Ohio 44073-0002, USA

**Email** [CustomerService@asminternational.org](mailto:CustomerService@asminternational.org)

**In Europe** American Technical Publishers Ltd.  
27-29 Knowl Piece, Wilbury Way, Hitchin Hertfordshire SG4 0SX,  
United Kingdom  
Telephone: 01462 437933 (account holders), 01462 431525 (credit card)  
[www.ameritech.co.uk](http://www.ameritech.co.uk)

**In Japan** Neutrino Inc.  
Takahashi Bldg., 44-3 Fuda 1-chome, Chofu-Shi, Tokyo 182 Japan  
Telephone: 81 (0) 424 84 5550

**Terms of Use.** This publication is being made available in PDF format as a benefit to members and customers of ASM International. You may download and print a copy of this publication for your personal use only. Other use and distribution is prohibited without the express written permission of ASM International.

No warranties, express or implied, including, without limitation, warranties of merchantability or fitness for a particular purpose, are given in connection with this publication. Although this information is believed to be accurate by ASM, ASM cannot guarantee that favorable results will be obtained from the use of this publication alone. This publication is intended for use by persons having technical skill, at their sole discretion and risk. Since the conditions of product or material use are outside of ASM's control, ASM assumes no liability or obligation in connection with any use of this information. As with any material, evaluation of the material under end-use conditions prior to specification is essential. Therefore, specific testing under actual conditions is recommended.

Nothing contained in this publication shall be construed as a grant of any right of manufacture, sale, use, or reproduction, in connection with any method, process, apparatus, product, composition, or system, whether or not covered by letters patent, copyright, or trademark, and nothing contained in this publication shall be construed as a defense against any alleged infringement of letters patent, copyright, or trademark, or as a defense against liability for such infringement.

# CHAPTER 1

---

---

## Introduction to Gear Heat Treatment

MODERN GEARS are made from a wide variety of materials. Of all these, steel has the outstanding characteristics of high strength per unit volume and low cost per pound. These are the primary reasons that steel gears are used predominantly in industry today. Furthermore, the vast majority of gears made from either plain carbon or alloy steels is heat treated to increase strength and life. Although both plain carbon and alloy steels with equal hardness exhibit equal tensile strengths, alloy steels are preferred because of higher hardenability and the desired microstructures of the hardened case and core needed for high fatigue strength of gears. Over 90% of the gears used in industrial applications today are made from alloy steels. Hence, the scope of this guide is limited to the heat treatment of alloy steel gears.

Heat treatment of alloy steel gears is a complex process, and its scope lies from surface hardening to core treatment with proper control of both case and core microstructures. A well-controlled heat treatment produces the desirable surface and core properties for resistance to various failure modes. These failure modes include bending and contact (pitting) fatigues, and failures due to simple surface wear of gear teeth. The type of heat treatment used significantly affects metallurgical properties of the gears and the subsequent failure modes of the gears.

In addition to hardness and acceptable case/core microstructures, a gear design engineer expects gears to maintain pre-heat-treat tooth geometry after heat treatment, if possible. This allows gears to be finished with such minor operations as honing or lapping at acceptable quality and cost. But, unfortunately, the quality of gear geometry after heat treatment, carburizing in particular, deteriorates due to distortion to the extent that grinding of gear teeth becomes essential; the degree of distortion depends on the material, heat treat process, and equipment used. Although grinding can improve the geometry of gear teeth even with high distortion, this increases manufacturing cost significantly. Furthermore, ground gears

with high distortion may not perform satisfactorily due to the fact that grinding may remove the required case and lower the surface hardness of teeth. Thus, for optimal gear performance and reasonable manufacturing cost, it is essential that gear designers and manufacturing engineers have a good understanding of the various heat treatment processes that are used primarily for industrial and aerospace gears.

Of the various heat treating processes currently available, five are frequently used to heat treat alloy steel gears. These processes are through hardening, case carburizing and hardening, nitriding, carbonitriding, and induction hardening. Analyses of these processes show case carburizing and hardening offers the highest torque-carrying capacity of gears. In fact, the torque capacity of a carburized and hardened gear set can be three to four times higher than that of a similar through-hardened gear set. It is also significantly higher than a nitrided or an induction-hardened set. For this reason, case carburized and hardened gears are extensively used in industrial, automotive, and aerospace applications. Nitriding process is used primarily because of low distortion and in applications where gears are not heavily stressed and do not require high case depths, for which nitriding is not cost effective. High case depths often produce unacceptable microstructures of the nitrided case detrimental to gear life.

Until recently, carburized and ground gears were not considered economical because of high finishing cost. This concept was based on some inefficient carburizing equipment and processes. With the recent development of improved heat treat equipment and some high-quality carburizing grade steels, it is now possible to control and predict heat treat distortion during carburizing and quenching to the extent that grinding time is significantly reduced. In some cases, minor modifications of pre-heat treat gear-cutting tools (hobs, shaper cutters) help to compensate heat treat distortion that reduce grind time even further. Also, carburized and hardened gear sizes are smaller compared with those heat treated by other processes for the same horsepower (hp) because of higher allowable stresses in design. This results in smaller gear units with lower cost/hp and shorter center distances between the gears. Hence, the use of carburized gears is increasing continually.

In spite of the fact that more gears are being carburized than in the past, the process is not yet fully understood from a distortion point of view. A large number of heat treating organizations still regard the process as a black art. These manufacturers forget that case carburizing, like any other manufacturing process, is very much a scientific process. The problems associated with this process are easily identifiable with proper explanation. This book has been specially prepared for this purpose. It is expected to provide a better understanding of the carburizing process to gear engineers. In this regard, problems associated with commonly used gear materials such as American Iron and Steel Institute (AISI) 8620 and AISI 9310 are discussed. Also discussed are problems with high-alloy steels

such as AISI 4330 and HP 9-4-30 that are used extensively in the aerospace industry. In many of these applications, even with high material cost per pound, an optimal design is achieved with gears made from these steels. This is due largely to controllable heat treat distortion of these materials that helps to reduce gear finishing cost.

To appreciate the advantages of the carburizing process, other heat processes such as through hardening, nitriding, carbonitriding, and induction hardening also are discussed, especially the limitations of these processes to optimal gear design. The distortion in the nitriding process, sometimes considered an alternative to carburizing, is comparatively less but cannot be ignored, particularly when conventional gas nitriding is used. For example, the quality of gas-nitrided gears may drop from American Gear Manufacturers Association (AGMA) class 10 to class 9 after nitriding, whereas the quality of similar carburized gears may go down to AGMA class 8. From the last decade to date, the use of through-hardened gears has been reduced significantly. On the other hand, induction hardening, particularly the dual frequency method, sometimes provides an alternative to carburizing and nitriding for large-sized gears.

As already mentioned, minor modification of pre-heat treat cutting tools designed to accommodate the expected distortion minimizes finishing operation and thus, gear cost. But this is possible only with known and consistent distortion of gears. Unfortunately, distortion characteristics of gears for various heat treat processes and materials are not easily available. For an optimal design, therefore, it is imperative that both design and manufacturing engineers become familiar with the various gear heat treat processes and understand the mechanism of heat treat distortion, for which some knowledge of the properties of iron (the basic ingredient of steel), iron-carbon phase diagram, and the properties of some common alloying elements is considered helpful.



## CHAPTER 2

---

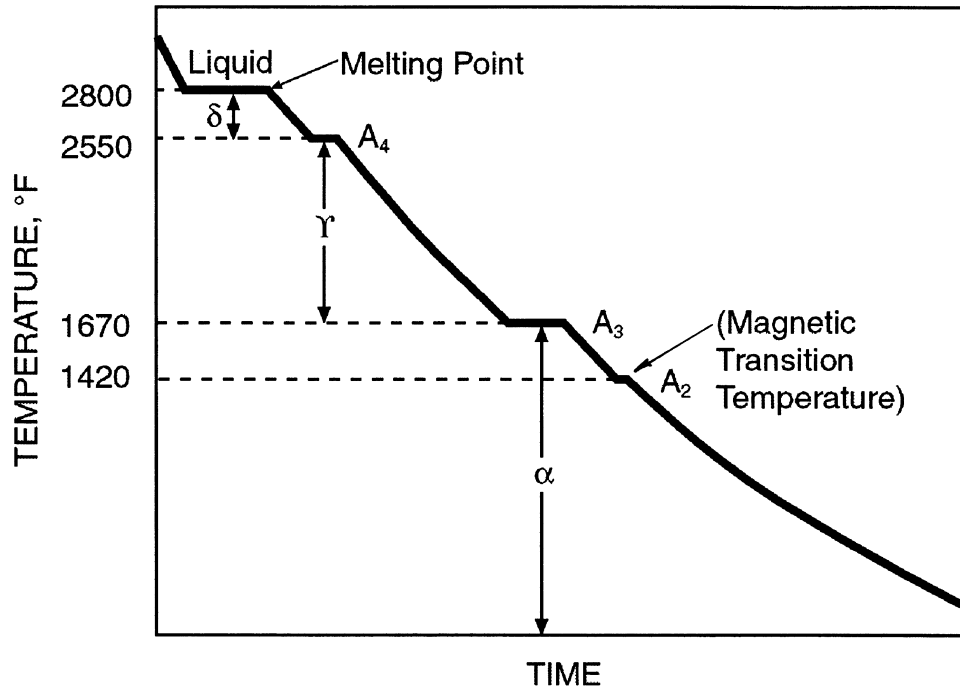
---

# Properties of Iron

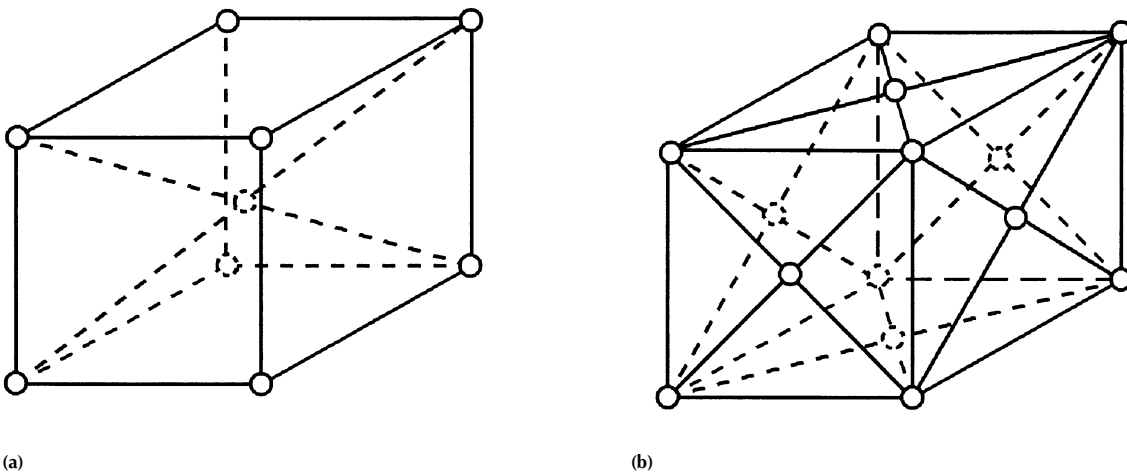
HEATING PURE IRON to its melting point and then allowing it to cool slowly results in an idealized time-temperature relationship (Fig. 2.1). As the iron cools, some discontinuation or temperature arrests are observed. These discontinuations are caused by physical changes of iron crystals. Some of the temperatures at which these changes take place are important for heat treatment of gears.

The first arrest at 1540 °C (2800 °F) marks the temperature at which the iron freezes or solidifies. Immediately after freezing, the iron atoms are arranged in what is termed the body-centered cubic (bcc) pattern. In this crystal structure, an iron atom is located at each of the eight corners and one in the center (Fig. 2.2a). This form of iron is known as delta ( $\delta$ ) iron. Then, at 1400 °C (2550 °F) ( $A_4$ , Fig. 2.1), iron undergoes an allotropic transformation, that is, rearrangement of atoms in the crystal. The new crystal structure becomes face-centered cubic (fcc) with an iron atom at each of the eight corners and also with an atom in the center of the six faces instead of one in the center of the cube (Fig. 2.2b). This form is known as gamma ( $\gamma$ ) iron. At 910 °C (1670 °F) ( $A_3$ , Fig. 2.1), iron undergoes another allotropic transformation and reverts to the bcc system. This structure, which is crystallographically the same as delta iron, is stable at all temperatures below the  $A_3$  point (Fig. 2.1) and is known as alpha ( $\alpha$ ) iron. The next arrest at 770 °C (1420 °F) ( $A_2$ , Fig. 2.1) is not caused by any allotropic change. It marks the temperature at which iron becomes ferromagnetic and is therefore termed the magnetic transition. Above this temperature, iron is non-magnetic.

These various temperature arrests on the cooling of iron are caused by evolutions of heat. On heating, the arrests occur in reverse order and are caused by absorption of heat. The critical points also may be detected by sudden changes in other physical properties, for instance, expansivity or electrical conductivity.



**Fig. 2.1** Idealized cooling curve for pure iron



**Fig. 2.2** Crystal structure of iron. (a) Body-centered cubic (alpha and delta iron). (b) Face-centered cubic (gamma iron)



## Alloys of Iron and Carbon

Steels are basically alloys of iron and carbon. The properties of iron and, hence, the steel are affected markedly as the percentage of carbon varies.

An iron-carbon phase diagram represents the relationship between temperatures, compositions, and crystal structures of all phases that may be formed by iron and carbon. Thus, it is felt some knowledge of the iron-carbon phase diagram is helpful for better understanding of gear heat treatment. A portion of this diagram for alloys ranging up to 6.7% of carbon is reproduced in Fig. 2.3; the upper limit of carbon in cast iron is usually not in excess of 5%. The left-hand boundary of the diagram represents pure iron, and the right-hand boundary represents the compound iron carbide,  $\text{Fe}_3\text{C}$ , commonly called cementite.

The beginning of freezing of the various iron-carbon alloys is given by the curve  $ABCD$ , termed the liquidus curve. The ending of freezing is given by the curve  $AHJEFC$ , termed the solidus curve. The freezing point of iron is lowered by the addition of carbon (up to 4.3%), and the resultant alloys freeze over a temperature range instead of at a constant temperature as does pure iron metal. The alloy containing 4.3% carbon, called the eutectic alloy of iron and cementite, freezes at a constant temperature as

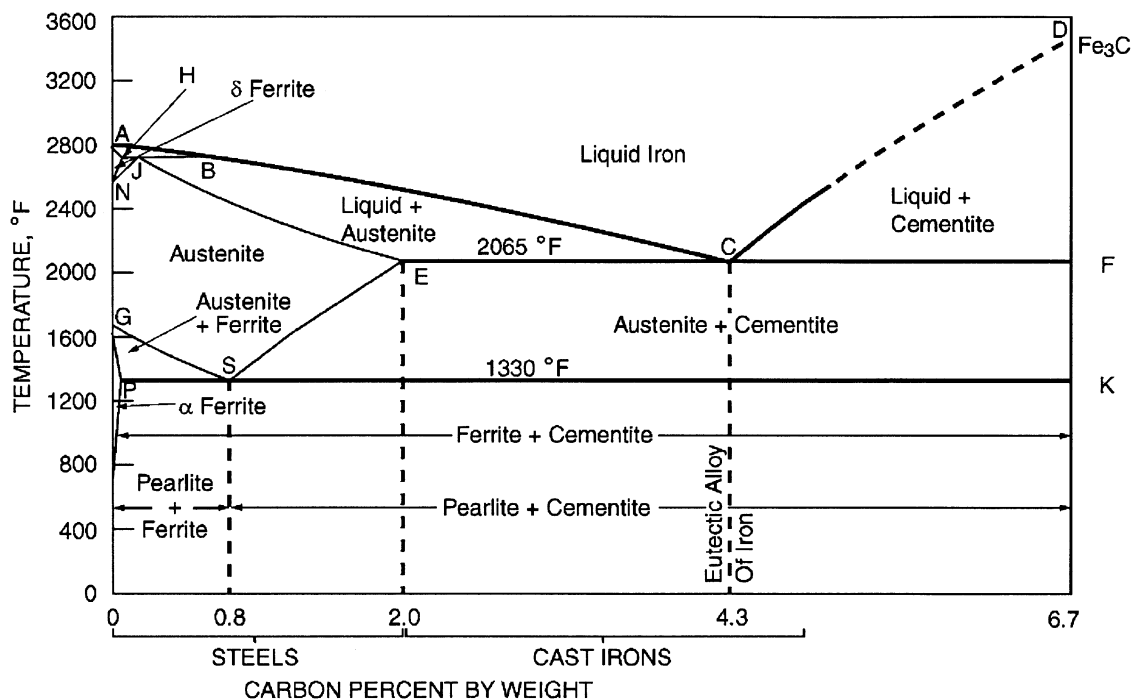


Fig. 2.3 Iron-carbon phase diagram

indicated by the point *C*. This temperature is 1130 °C (2065 °F), considerably below the freezing point of pure iron.

Carbon has an important effect on the transformation temperatures (critical points) of iron. It raises the  $A_4$  (Fig. 2.1) temperature and lowers the  $A_3$  (Fig. 2.1) temperature. The effect on the  $A_3$  (Fig. 2.1) temperature is significant in the heat treatment of carbon and low-alloy steels, while that on the  $A_4$  (Fig. 2.1) is important in the heat treatment of certain high-alloy steels.

It is possible for solid iron to absorb or dissolve carbon, the amount being dependent on the crystal structure of the iron and its temperature. The body-centered (alpha or delta) iron can dissolve only small amounts of carbon, whereas the face-centered (gamma) iron can dissolve a considerable amount, the maximum being about 2.0% at 1130 °C (2065 °F) (Fig. 2.3). This solid solution of carbon in gamma iron is termed austenite. The solid solution of carbon in delta iron is termed delta ferrite, and the solid solution of carbon in alpha iron is termed alpha ferrite or, more simply, ferrite.

The mechanism of solidification of iron-carbon alloys, especially those containing less than 0.6% carbon, is rather complicated and is of no importance in the heat treatment of carbon steels. It is sufficient to know that all iron-carbon alloys containing less than 2.0% carbon steel immediately or soon after solidification consist of the single-phase austenite.

The part of the iron-carbon diagram that is of concern with the heat treatment of steel is reproduced on an expanded scale in Fig. 2.4. Regardless of the carbon content, steel exists as austenite above the line *GOSE*. Steel of composition *S* (0.80% of carbon) is designated as “eutectoid” steel, and those with lower or higher carbon as “hypoeutectoid” and “hypereutectoid,” respectively.

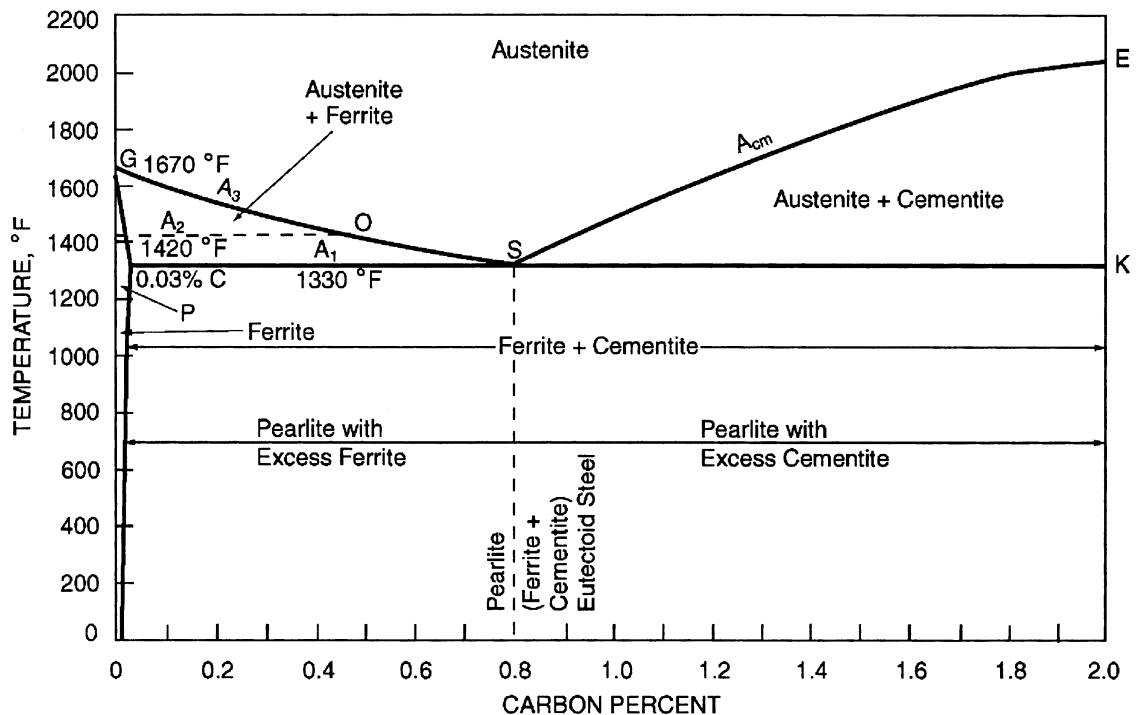
A eutectoid steel, when cooled at very slow rates from temperatures within the austenitic region, undergoes no change until the temperature denoted by *PSK* is reached. At this temperature of 720 °C (1330 °F), also known as the  $A_1$  temperature, the austenite transforms completely to an aggregate of ferrite and cementite. This aggregate is also known as pearlite. The  $A_1$  temperature is, therefore, frequently referred to as the pearlite point. Because the  $A_1$  temperature involves the transformation of austenite to pearlite (which contains cementite,  $Fe_3C$ ), pure iron does not possess an  $A_1$  transformation. Theoretically, iron must be alloyed with a minimum of 0.03% of carbon before the first minute traces of pearlite can be formed on cooling (point *P*). If the steel is held at a temperature just below  $A_1$  (either during cooling or heating), the carbide in the pearlite tends to coalesce into globules or spheroids. This phenomenon is known as spheroidization, which later helps to form martensitic steel structure.

Hypoeutectoid steels (less than 0.80% carbon), when slowly cooled from temperatures above the  $A_3$ , begin to precipitate ferrite when the  $A_3$  (*GOS*)

line is reached. As the temperature drops from the  $A_3$  to  $A_1$ , the precipitation of ferrite increases progressively, and the amount of the remaining austenite reaches eutectoid composition and, upon further cooling, transforms completely into pearlite. The lower the carbon content, the higher the temperature at which ferrite begins to precipitate and the greater the amount in the final crystal structure.

Hypereutectoid steels (more than 0.80% of carbon), when slowly cooled from temperatures above the line  $SE$  ( $A_{cm}$ ), begin to precipitate cementite when the  $A_{cm}$  line is reached. As the temperature drops from the  $A_{cm}$  to  $A_1$ , the precipitation of cementite increases progressively, and the amount of the remaining austenite decreases accordingly, its carbon content having been depleted. At the  $A_1$  temperature, the remaining austenite reaches eutectoid composition and upon further cooling transforms completely into pearlite. The higher the carbon content, the higher the temperature at which cementite begins to precipitate and the greater the amount in the final crystal structure.

The temperature range between the  $A_1$  and  $A_3$  is called the critical transformation range. Theoretically, the critical points in any steel should occur at about the same temperatures on either heating or cooling very slowly. Practically, however, they do not because the  $A_3$  and  $A_1$  points are affected slightly by the rate of heating but tremendously by the rate of cooling. Thus, rapid rates of heating raise these points only slightly, but



**Fig. 2.4** Phase diagram for carbon steels

rapid rates of cooling lower the temperatures of transformation considerably. To differentiate between the critical points on heating and cooling, the small letters “c” (for *chauffage*, from the French, meaning *heating*) and “r” (for *refroidissement*, from the French, meaning *cooling*) are added. The terminology of the critical points thus becomes  $Ac_3$ ,  $Ar_3$ ,  $Ac_1$ ,  $Ar_1$ , and so on. The letter “e” is used to designate the occurrence of the points under conditions of extremely slow cooling on the assumption that this represents equilibrium conditions (“e” for *equilibrium*), for instance, the  $Ae_3$ ,  $Ae_1$ , and  $Ae_{cm}$ .

It is important to remember that the iron-carbon phase diagram represents transformation and crystal structures in slowly cooled steel under equilibrium conditions. Any departure from equilibrium conditions, as by rapid cooling, changes transformation characteristics, forming different grades of heat treated steels.

---

## Transformation (Decomposition) of Austenite

---

In alloys of iron and carbon, austenite is stable only at temperatures above the  $Ae_1$  (720 °C, or 1330 °F). Below this temperature it decomposes into mixtures of ferrite and cementite. The end product or final structure is greatly influenced by the temperature at which the transformation occurs, and this, in turn, is influenced by the rate of cooling. Because the mechanical properties may vary widely depending on the decomposition products of the parent austenite, a knowledge of how austenite decomposes and the factors influencing it is necessary for a clear understanding of the heat treatment of steel. The progressive transformation of austenite under equilibrium conditions (extremely slow cooling) has been described already. Practically, however, steel is not cooled under equilibrium conditions, and consequently, the critical points on cooling always occur at temperatures lower than indicated in Fig. 2.4.

If samples of steel, for example of eutectoid carbon content for the sake of simplicity, are cooled from above the  $Ae_1$  at gradually increasing rates, the corresponding  $Ar$  transformation occurs at progressively lower temperatures (Fig. 2.5). This transformation is distinguished from that occurring under extremely slow rates of cooling ( $Ar_1$ ) by the designation  $Ar'$ . As the rate of cooling of this steel is increased, an additional transformation (termed the  $Ar''$ ) appears at relatively low temperature (approximately 220 °C, or 430 °F). If the rate of cooling is still further increased, the  $Ar'$  transformation is suppressed entirely, and only the  $Ar''$  transformation is evident. It should be noted that the temperature of the  $Ar''$  is not affected by the rate of cooling, whereas the temperature of the  $Ar'$  may be depressed to as low as 565 °C (1050 °F) in a particular steel.

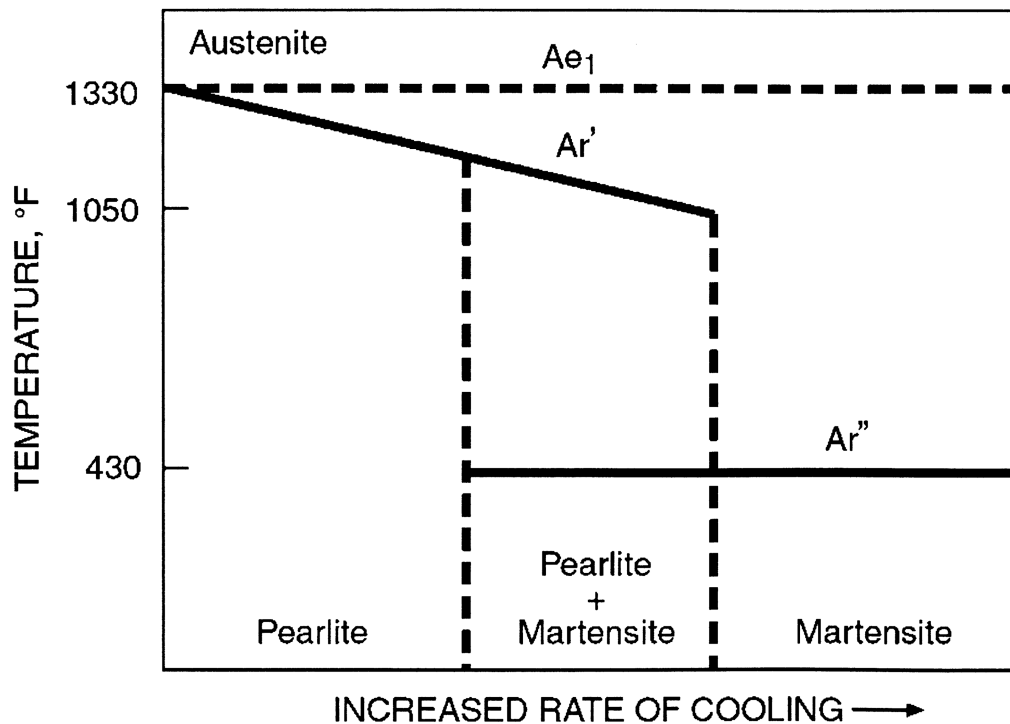
The product of the  $Ar'$  transformation is fine pearlite. As the temperature of the  $Ar'$  is gradually lowered, the lamellar structure of the resulting

pearlite becomes correspondingly finer, and the steel becomes harder and stronger. The product of the  $Ar''$  transformation is martensite, which is the hardest and most brittle of the transformation products of austenite and is characterized by a typical acicular crystal structure.

The phenomenon of the occurrence of both the  $Ar'$  and  $Ar''$  transformations is known as the split transformation. The actual amounts of these two constituents are functions of the rates of cooling, the slower rates resulting in more pearlite and less martensite and the faster rates resulting in more martensite and less pearlite.

The course of transformation of austenite when the steel is quenched to and held at various constant elevated temperature levels (isothermal transformation) is conveniently shown by a diagram known as the S-curve (also termed the TTT diagram, for time, temperature, and transformation). Such a diagram for eutectoid carbon steel is shown in Fig. 2.6.

**Austenite to Pearlite.** Austenite containing 0.80% carbon, cooled quickly to and held at 700 °C (1300 °F), does not begin to decompose (transform) until after about 15 min and does not completely decompose until after approximately 5 h (Fig. 2.6). Thus, at temperatures just below the  $Ae_1$ , austenite is stable for a considerable length of time. The product

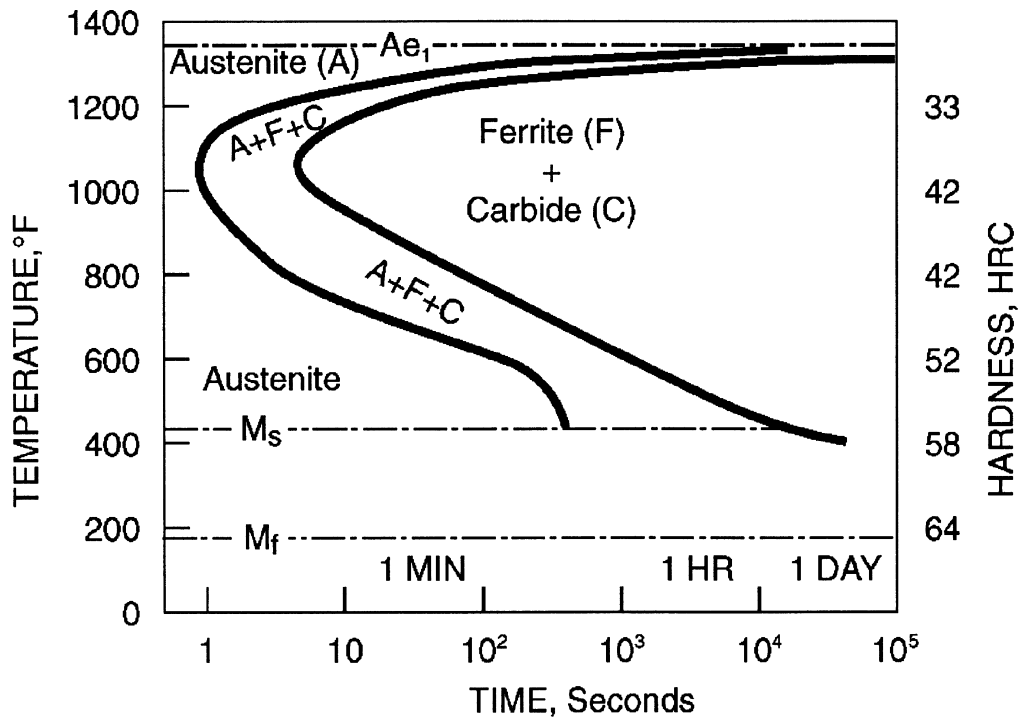


**Fig. 2.5** Schematic showing the effect of cooling rate on the transformation temperatures and decomposition products of austenite of eutectoid carbon steel

of the decomposition of austenite at this temperature is coarse pearlite of relatively low hardness. If the austenite is cooled quickly and held at a somewhat lower temperature, approximately 650 °C (1200 °F), decomposition begins in approximately 5 s and is completed after about 30 s. The resultant pearlite is finer and harder than pearlite formed at 700 °C (1300 °F). At a temperature close to 565 °C (1050 °F), the austenite decomposes extremely rapidly, only about 1 s elapsing before the transformation starts and 5 s until it is completed. The resultant pearlite is extremely fine and its hardness is relatively high. This region of the S-curve where the decomposition of austenite to fine pearlite proceeds so rapidly is termed the “nose” of the curve because of its appearance.

**Austenite to Bainite.** When austenite cools to temperatures below the nose of the S-curve (565 °C, or 1050 °F), the time for its decomposition begins to increase (Fig. 2.6). The final product of decomposition now is not pearlite, but a new acicular constituent called bainite. Bainite possesses unusual toughness with hardness even greater than that of very fine pearlite.

Depending on the temperature, a certain finite interval of time is necessary before austenite starts to transform into either pearlite or



**Fig. 2.6** Isothermal transformation diagram (S-curve) for eutectoid carbon steel

bainite. Additional time is necessary before the transformations are completed.

**Austenite to Martensite.** If the austenite is cooled to a relatively low temperature (below 220 °C, or 430 °F) for the eutectoid carbon steel, partial transformation takes place instantaneously (with the speed of an elastic wave). The product of this transformation is martensite. Martensite transformation continues over a temperature range, and the amount that transforms is a function of the temperature. Only minute amounts transform at 220 °C (430 °F); practically all of the austenite is transformed at 80 °C (175 °F). The beginning of this transformation range is termed the  $M_s$  (martensite, start), and the end of the range is termed the  $M_f$  (martensite, finish). As long as the temperature is held constant within the  $M_s$ – $M_f$  range, that portion of the austenite that does not transform instantaneously to martensite remains untransformed for a considerable length of time, eventually transforming to bainite. Martensite has a body-centered tetragonal crystal structure, which is a distortion of the normal bcc crystal. In some steels, the reaction is accompanied by a large increase in volume resulting in a highly stressed structure. Hardness of martensite is, in general, much higher than austenite. The degree of hardening is a direct function of increasing carbon content.

In ordinary heat treatment of the plain carbon steels, austenite does not transform into bainite. Transformation of the austenite takes place either above or at the nose of the S-curve, forming pearlite, or in passing through the  $M_s$ – $M_f$  range, forming martensite, or both. It is evident that in order for austenite to be transformed entirely into martensite, it must be cooled sufficiently rapidly so that the temperature of the steel is lowered past the nose of the S-curve in less time than is necessary for transformation to start at this temperature. If this is not accomplished, part of the steel transforms into pearlite at the high temperature ( $Ar'$ ), and the remainder transforms into martensite at the low temperature ( $Ar''$ , or  $M_s$ – $M_f$ , temperature range).

**Continuous Cooling and Transformation of Steel.** Figure 2.7 represents a theoretical S-curve on which are superimposed five theoretical cooling curves. Curves *A* to *E* represent successively slower rates of cooling, as would be obtained, for instance, by cooling in iced brine, water, oil, air, and in the furnace, respectively.

The steel cooled according to curve *E* begins to transform at temperature  $t_1$  and completes transformation at  $t_2$ . The final product is coarse pearlite with relatively low hardness. When cooled according to curve *D*, transformation begins at  $t_3$  and is completed at  $t_4$ . The final product is fine pearlite, and its hardness is greater than the steel cooled according to curve *E*. When cooled according to curve *C*, transformation begins at  $t_5$  and is only partially complete when temperature  $t_6$  is reached. The product of this partial transformation is very fine pearlite. The remainder of the austenite does not decompose until the  $M_s$  temperature is reached,

when it begins to transform to martensite, completing this transformation at the  $M_f$  temperature. The final structure is then a mixture of fine pearlite and martensite (typical of incompletely hardened steel, frequently termed “slack-quenched” steel) with a higher hardness than is obtained with the steel cooled according to curve  $D$ . The rate of cooling represented by curve  $B$  is just sufficient to intersect the nose of the S-curve; consequently, only a minute amount of the austenite decomposes into fine pearlite at temperature  $t_7$ . The remainder of the austenite is unchanged until the martensite transformation range is reached. If the steel is cooled at a slightly faster rate so that no transformation takes place at the nose of the S-curve, the steel is completely hardened. This rate is termed the critical cooling rate and is defined as the slowest rate at which the steel can be cooled and yet be completely hardened. Because this rate cannot be directly determined, the rate indicated by curve  $B$ , producing only a trace of fine pearlite, is frequently used as the critical cooling rate. The hardness of the resultant martensite is equivalent to the maximum that can be obtained. Samples cooled at a faster rate, such as that indicated by curve  $A$ , are also completely martensitic, but no harder than the sample cooled according to the critical cooling rate.

The rate at which a steel cools through the temperature range in the vicinity of the nose of the S-curve is of critical importance. Somewhat

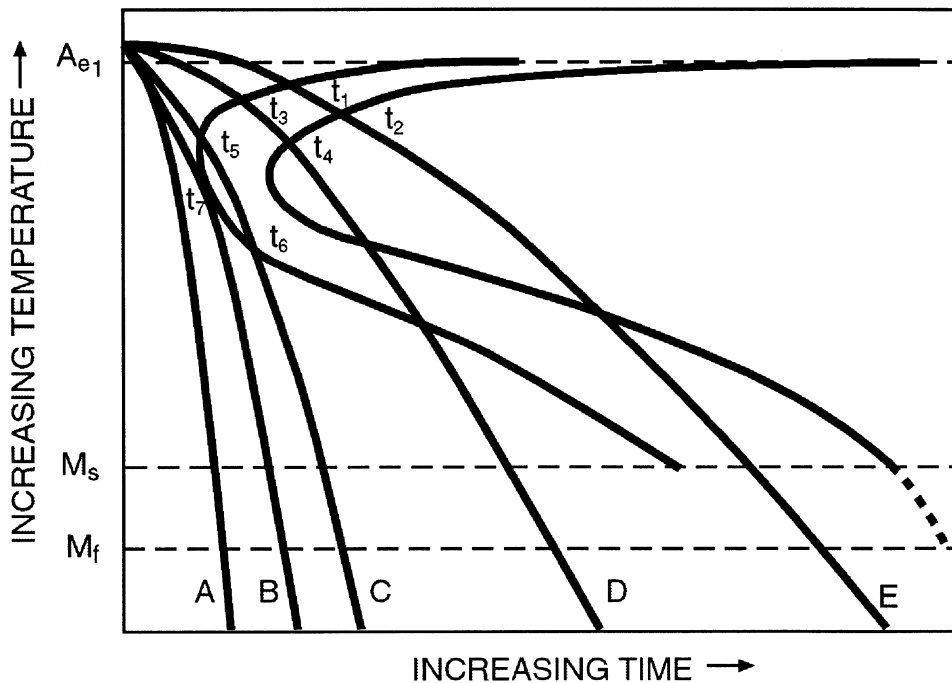


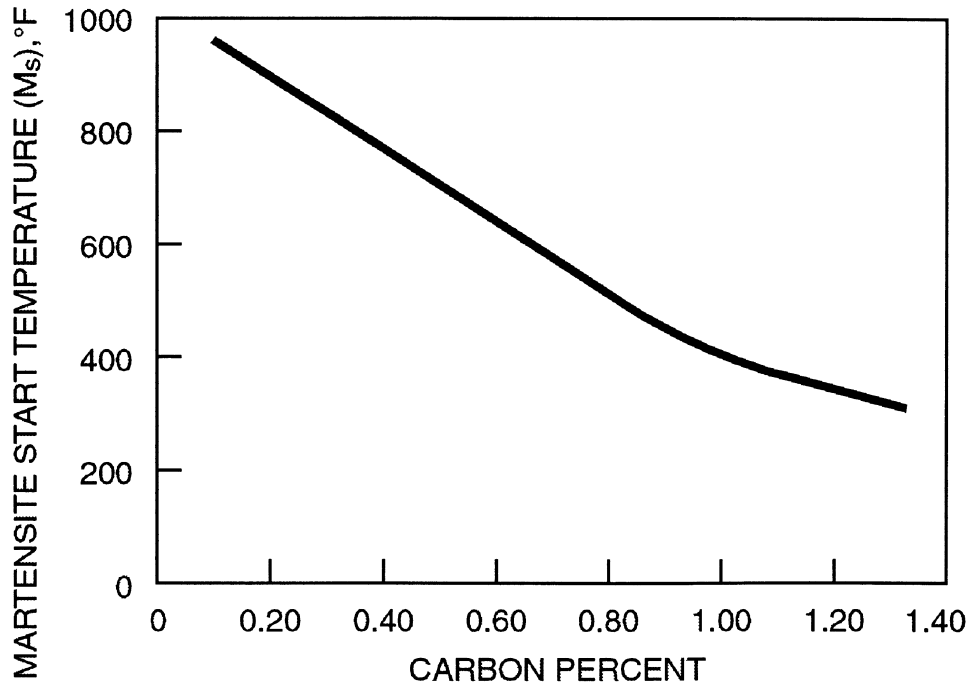
Fig. 2.7 Schematic illustrating the relationship between the S-curve and continuous cooling curves



slower rates of cooling above and below this temperature range can be tolerated and yet obtain a completely hardened steel, provided the cooling through the temperature interval at the nose of the S-curve is sufficiently fast. In practice, however, steels usually are cooled rapidly from the quenching temperature to relatively low temperatures (approximately 260 °C, or 500 °F) and then allowed to cool in air.

Although these discussions of the decomposition of austenite have been limited to a steel of eutectoid composition, other steels behave in a similar manner, the temperatures and times of reactions being different. In hypoeutectoid steels, free ferrite and pearlite are formed if transformation begins above the temperature range of the nose of the S-curve; the amount of free ferrite decreases as the temperature of transformation approaches the nose of the curve. In hypereutectoid steels, free cementite plus pearlite are formed if transformation occurs above the nose. The time for the start of the transformation at the nose increases as the carbon increases up to the eutectoid composition and then decreases with further increase in carbon. That is, the nose is shifted to the right with respect to the time axis (Fig. 2.6) as the carbon is increased to 0.8% and to the left with further increase in carbon content.

Both the  $M_s$  and  $M_f$  temperatures are markedly lowered by increasing carbon content, as is shown for  $M_s$  in Fig. 2.8. The  $M_f$  temperatures of the



**Fig. 2.8** Influence of carbon on the start of the martensite transformation of high-purity iron-carbon alloys

plain carbon steels have not been adequately determined; available information indicates that the  $M_f$  of high carbon steels is actually below room temperature. Slight amounts of austenite are thus frequently retained in quenched steels, especially in the higher-carbon grades, even when cooled to room temperature.

With this background in the properties of iron, iron-carbon phase diagram, it is expected that it will now be easier to appreciate the mechanics and problems of gear heat treat processes.

# CHAPTER 3

---

---

## Heat Treatment of Gears

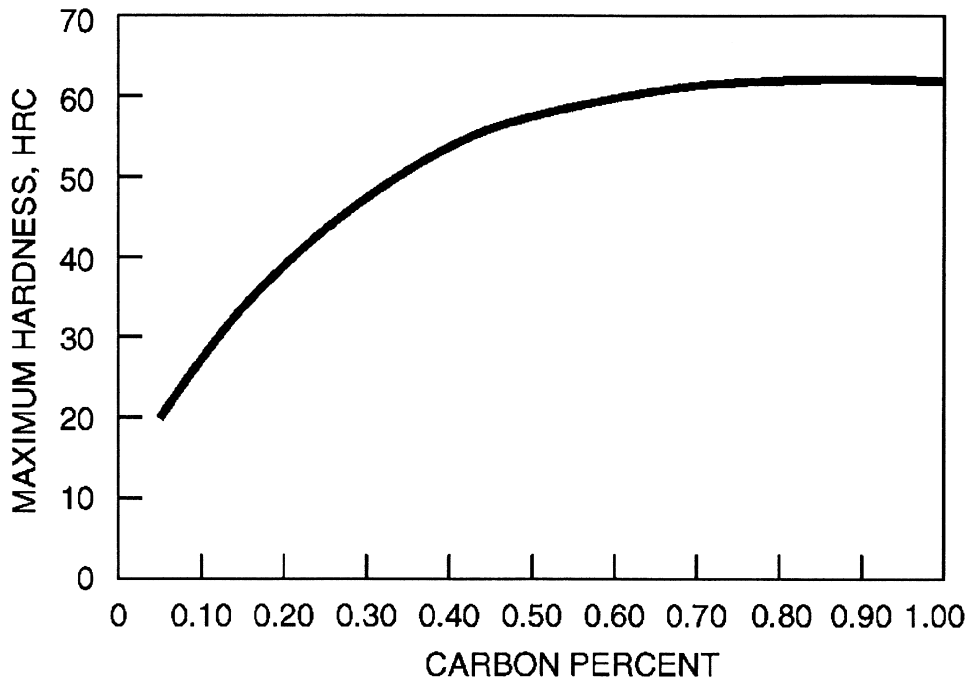
GEAR HEAT TREATING operations consist of subjecting the gears to a definite time-temperature cycle as for any steel, which may be divided into three parts: heating, holding at temperature (soaking), and cooling. Individual cases vary, but certain fundamental objectives need to be stated.

The rate of heating is not particularly important unless a gear is in a highly stressed condition, such as is imparted by severe cold working or prior hardening. In such instances, the rate of heating should be slow. Frequently, this is impracticable because furnaces already may be at operating temperatures. Placing gears at room temperature in the hot furnace may cause distortion or even cracking. This danger can be minimized by the use of a preheating furnace maintained at a temperature below the  $A_1$  (720 °C, or 1330 °F). Gears preheated for a sufficient period can be transferred to the furnace at operating temperature without any detrimental effect. This procedure is also advantageous when treating gears with considerable variations in section thickness.

The objective of holding a gear at any heat treating temperature is to ensure uniformity of temperature throughout its entire volume. Obviously, thin section gears need not be soaked as long as thick section ones, but if different thicknesses exist in the same piece, the period required to heat the thickest section uniformly governs the time at a temperature. A rule frequently used is to soak a half hour for every 25 mm (1 in.) of gear blank thickness.

On the other hand, the rate of cooling affects the crystal structure and properties of a steel and this, in turn, is governed by such factors as mass, quenching media, and so on. It must be realized that the thicker the section is, the slower the rate of cooling will be regardless of the method of cooling used.

The maximum hardness that can be obtained in completely hardened steels depends primarily on the carbon content. The relationship of maximum hardness to carbon content is shown in Fig. 3.1. It is to be noted the maximum hardness of any steel does not increase significantly above



**Fig. 3.1** Relation of maximum attainable hardness of quenched steels to carbon content. Courtesy Darle W. Dudley, *Handbook of Practical Gear Design*, Technomic Publishing Company, Inc., 1994

60 HRC after a carbon content of 0.60% as illustrated in this figure. Greater amounts of carbon put more carbides in the gear surface. This makes the gear more wear resistant but does not help to increase the hardness of the gear. The “eutectoid” point (0.85% carbon on the surface) is considered an optimum for case-carburized and hardened gears. Carbon in the range of 0.10 to 0.20% considerably reduces the maximum hardness that can be attained in steels. This range is generally beneficial in the core of carburized and hardened gears for high bending fatigue life.

## Major Heat Treat Processes

A great majority of industrial, automotive, and aerospace gears are heat treated by one of the following processes:

- Through-hardening
- Carburizing and hardening
- Nitriding
- Carbonitriding
- Induction hardening

Each of these processes has its benefits and limitations when applied to gears. It is up to the gear design engineer to select a particular process for an optimal design. In applications requiring high load capacity and long life for gears under occasional overload conditions, the carburizing and hardening process followed by finish grinding may be selected, whereas nitriding, offering low distortion, may be the right choice for gears that are not subjected to very high load and do not require high quality.

In the following chapters, each of the processes is discussed in detail with special emphasis on the limitations of the process to gear design and manufacturing.

# CHAPTER 4

---

---

## Through-Hardening Gears

THE THROUGH-HARDENING PROCESS is generally used for gears that do not require high surface hardness. Typical gear tooth hardness after through hardening ranges from 32 to 48 HRC. Most steels that are used for through-hardened gears have medium carbon (0.3–0.6%) and a relatively low alloy content (up to 3%). The purpose of alloy content is to increase hardenability. The higher the hardenability, the deeper is through hardening of gear teeth. Since strength increases directly with hardness, high hardenability is essential for through hardening steels. High hardenability, again, has some adverse effect on material ductility and impact resistance. The other drawback of through-hardened gears is lower allowable contact stresses than those of surface-hardened gears. This tends to increase the size of through-hardened gears for the same torque capacity compared with those with surface hardened.

In through hardening, gears are first heated to a required temperature and then cooled either in the furnace or quenched in air, gas, or liquid. The process may be used before or after the gear teeth are cut. If applied before cutting the teeth, the hardness usually is governed and limited by the most feasible machining process. Since these gear teeth are cut after heat treatment, no further finishing operation is needed. On the other hand, gears that are designed for hardness above the machining limit are first cut to semifinish dimensions and then through hardened. In case of some minor heat treat distortion, a finishing operation such as lapping or grinding is very often used to improve the quality of these gears (AGMA class 10 and above); for quality up to class 9, gears are finished cut at least one AGMA class above the requirement prior to heat treatment.

Four different methods of heat treatment are primarily used for through-hardened gears. In ascending order of achievable hardness, these methods are annealing, normalizing and annealing, normalizing and tempering, and quenching and tempering. Sometimes, hardnesses of through-hardened gears are specified and measured in other scales besides

**Table 4.1 Approximate relation between various hardness-test scales**

Brinell(a)	Rockwell						Vickers pyramid	Tukon (Knoop)
	C	A	30-N	15-N	B	30-T		
...	70	86.5	86.0	94.0	...	...	1076	...
...	65	84.0	82.0	92.0	...	...	820	840
...	63	83.0	80.0	91.5	...	...	763	790
614	60	81.0	77.5	90.0	...	...	695	725
587	58	80.0	75.5	89.3	...	...	655	680
547	55	78.5	73.0	88.0	...	...	598	620
522	54	77.5	71.0	87.0	...	...	562	580
484	50	76.0	68.5	85.5	...	...	513	530
460	48	74.5	66.5	84.5	...	...	485	500
426	45	73.0	64.0	83.0	...	...	446	460
393	52	71.5	61.5	81.5	...	...	413	425
352	38	69.5	57.5	79.5	...	...	373	390
301	33	67.0	53.0	76.5	...	...	323	355
250	24	62.5	45.0	71.5	...	...	257	...
230	20	60.5	41.5	69.5	...	...	236	...
200	...	...	...	...	93	78.0	91.0	210
180	...	...	...	...	89	75.5	89.5	189
150	...	...	...	...	80	70.0	86.5	158
100	...	...	...	...	56	54.0	79.0	105
80	...	...	...	...	47	47.7	75.7	...
70	...	...	...	...	34	38.5	71.5	...

(a) Load, 3000 kgf; diam, 10 mm (0.4 in.)

Rockwell, such as Vickers and Brinell. Table 4.1 shows an approximate relationship among the various commonly used hardness scales.

## Through-Hardening Processes

**Annealing** refers to any heating and cooling operation that is usually applied to induce softening. There are two types of annealing—full and process. In full annealing, the steel is heated usually to approximately 38 °C (100 °F) above the upper critical temperature and held for the desired length of time, followed by very slow cooling as in the furnace. The purposes of full annealing are to:

- Soften the steel and improve ductility and machinability
- Relieve internal stresses caused by previous treatment and improve dimensional stability
- Refine the grain structure

In process annealing, the steel is heated to a temperature below or close to the lower critical temperature followed by the desired rate of cooling. The purpose here is to soften the steel partially and to release the internal stresses. In this treatment, grain refinement by phase transformation is not accomplished as it is in full annealing. Process annealing uses temperatures between 550 and 650 °C (1020 and 1200 °F).

**Table 4.2 Typical Brinell hardness ranges of gears after through hardening**

Material (AISI steel)	Brinell hardness (HB)			Material (AISI steel)	Brinell hardness (HB)		
	Annealed; normalized and annealed	Normalized and tempered	Maximum Brinell hardness, quench and tempered		Annealed; normalized and annealed	Normalized and tempered	Maximum Brinell hardness, quench and tempered
4130	155–200	170–215	350	4145	195–240	285–330	450
8630	155–200	170–215	350	4150	195–240	285–330	450
4140	185–230	260–300	425	4340	210–255	300–340	480
4142	185–230	260–300	425	HP 9-4-30	200–240	(a)	520
8640	185–230	260–300	425	Maraging steel	200–240	(a)	485

(a) Process generally is not used with these types of materials.

Gears with hardness up to 34 HRC are fully annealed by heating to 800 to 900 °C (1475 to 1650 °F) and then furnace cooled to a prescribed temperature, generally below 315 °C (600 °F). Typical hardnesses obtained after full annealing gears of different materials are shown in Table 4.2.

**Normalizing and Annealing.** In general, the term *normalizing* refers to the heating of steel to approximately 38 °C (100 °F) above the upper critical temperature, followed by cooling in still air. The normalizing and annealing process is used, either singularly or in a combination, as a grain structure homogenizing for alloy steel gears. The process also is used to reduce metallurgical nonuniformity such as segregated alloy microstructures from previous mechanical working. A hypoeutectoid steel consisting of a structure of ferrite and coarse pearlite may be made easier to machine if the ferrite and cementite are more finely distributed. A very soft steel has a tendency to tear in machining; therefore, some increase in hardening obtained by normalizing leads to a more brittle chip and thus improves machinability. Some through-hardened gears may just require hardness obtained with normalizing and annealing.

**Normalizing and Tempering.** Normalizing consists of heating gears to 870 to 980 °C (1600 to 1800 °F) and then furnace cooling in still or circulated air. This process results in higher hardness than annealing, with hardness being a function of the grade of steel and gear tooth size. However, normalizing does not increase hardness significantly more than annealing does, regardless of tooth size for plain carbon steels containing up to 0.4% carbon. But it definitely helps to ensure homogeneous microstructure of steels. After normalizing, alloy steel gears are tempered at 540 to 680 °C (1000 to 1250 °F) for uniform hardness and dimensional stability.

**Quench and Temper.** The quench and temper process involves heating the gears to form austenite at 800 to 900 °C (1475 to 1650 °F), followed by quenching in a suitable media such as oil. The rapid cooling causes the gears to become harder and stronger by the formation of martensite. Hardened gears then are tempered at a temperature, generally below 690 °C (1275 °F), to achieve the desired mechanical properties. This process is the most commonly used for through-hardened gears.

Tempering lowers both the hardness and strength of quenched steels but improves materials properties such as ductility, toughness, and impact



resistance. The tempering temperature must be carefully selected based on the specified hardness range, the quenched hardness of the part, and the material. Normally, the optimum tempering temperature is the highest temperature possible while maintaining the specified hardness range. It is to be remembered that hardness after tempering varies inversely with the tempering temperature used. After tempering, parts usually are air cooled at room temperature.

Some steels can become brittle and unsuitable for service if tempered in the temperature range of 430 to 650 °C (800 to 1200 °F). This phenomenon is called temper brittleness and generally is considered to be caused by segregation of alloying elements or precipitation of compounds at ferrite and austenite grain boundaries. If the gear materials under consideration must be tempered in this range, investigation to determine their susceptibility to temper brittleness is needed. Molybdenum content of 0.25 to 0.50% has been shown to eliminate temper brittleness in most steels. (Note: Temper brittleness should not be confused with the tempering embrittlement phenomenon that sometimes results from tempering at a lower temperature range, such as 260 to 320 °C, or 500 to 600 °F.)

The major factors of the quench and temper process that influence hardness and material strength are:

- Material chemistry and hardenability
- Quench severity
- Section size
- Time at temper temperature

Of the four commonly used through-hardening processes, the quench and temper method is used widely, particularly when:

- The hardness and mechanical properties required for a given application cannot be achieved by any of the other three processes.
- It is necessary to develop mechanical properties (core properties) in gears that will not be altered by any subsequent heat treatment such as nitriding or induction hardening.

Typical hardness ranges achieved for different materials after through hardening by different processes are illustrated in Table 4.2.

---

## Some Hints on Through-Hardened Gear Design

---

After finalizing a design, a gear designer needs to specify the following information on a through-hardened gear drawing. This information will

help to minimize confusion for all involved with gear manufacturing and material procurement:

- Grade of steel with Aerospace Material Specification (AMS), if applicable
- AMS specification for material cleanliness, if required
- Hardnesses on tooth surface and at the core
- Gear quality level

Each hardness callout should have at least a range of 4 points in HRC scale or 40 points in Brinell hardness (HB). Also, specify a tempering temperature range on the drawing. This allows gear manufacturing engineers to select a particular tempering temperature for a specified hardness.

## Hardness Measurement

---

The hardness of through-hardened gears generally is measured either on the gear tooth end face or rim section. This is the hardness that is used for gear rating purposes. Sometimes, achieving specified hardness on tooth end face may not necessarily assure the desired hardness at the roots of teeth because of grade of steel, tooth size, and heat treat practice. If gear tooth root hardness is critical to a design, then it should be specified and measured on a sample (coupon) processed with the gears. However, needless increase of material cost by selecting a higher grade of steel should be avoided.

## Heat Treat Distortion of Through-Hardened Gears

---

All steel gears experience distortion during a heat treat process. It is a physical phenomenon and cannot be eliminated from any heat treat operation, although distortion of through-hardened gears is not as severe as in other processes discussed in Chapters 5, 6, and 7. Still, through-hardened gears, particularly quench and tempered class, experience enough distortion that will eventually lower the quality level of gears after heat treatment. This necessitates a finishing operation for higher quality. In general, some materials expand after a through-hardening operation while others contract. This requires a suitable stock allowance to be provided on teeth for finish machining before heat treatment of gears that are likely to distort. The allowance needs to include expansion or contraction of material and also distortion of tooth geometry. For materials with predictable and uniform distortion, gears could be cut to include the distortion so that no finishing operation is required, possibly up to AGMA class 10 gear tooth quality. A great majority of materials

**Table 4.3 Distortion ratings of through-hardened gears**

Material	AMS specification	AMS quality	Hardness (HRC)	Distortion rating
AISI 4340	6414	2300	48/50	Good(a)
Maraging 250	6520	2300	49/52	Predictable and good(a)
Maraging 300	6521/6514	2300	52/56	Predictable and good(a)
AISI 4140	6382	2300	48/50	Good(a)

(a) Within one AGMA class of gear quality.

listed in Table 4.2 seem to expand during the through-hardening process, whereas a few materials such as maraging steel are found to contract. The amount of expansion or contraction depends on alloy content, quality of steel, and configuration of gears. In this regard, knowledge of distortion characteristics is helpful in optimizing the manufacturing process of gears. When gears are made from a material without any previous heat treat distortion data, an experimental investigation is beneficial to establish the distortion characteristics of the material. With such data, cost-effective manufacturing methods can be established. An investigation of this nature carried out by an aerospace company to determine the heat treat distortion characteristics of a through-hardened gear rack for an aerospace application is discussed at the end of this chapter. Table 4.3 shows a comparative distortion rating of some preferred through-hardening materials for gears.

## Applications

Of the four different through-hardening processes described, those gears hardened by quenching and tempering have some limited use in power transmission applications. The other three processes are only employed to either improve machinability or to enhance homogeneous grain structure of the gear steel. Use of through-hardened gears is limited because of the low surface hardness that results in low gear pitting life and low power density gearbox compared with the one made with case-hardened gears. Also, for similar torque capacity, through-hardened gears are larger with higher pitch line velocity. This increases dynamic problems substantially in a gearbox. However, in a bending strength limited design, through-hardened gears sometimes are successfully used, particularly for large gears (over 508 mm, or 20 in., OD) that normally exhibit high distortion if a case hardening process is used. An example for such an application is the internal ring gear of an epicyclic gearbox. These gears are usually designed with hardness in the range of 32 to 34 HRC that can be finish cut after hardening, thus eliminating costly finishing operations. Through-hardened gears also are found to be effective in applications susceptible to gear scuffing. It is claimed that profile conformance of through-hardened gears, because of their low surface hardness, reduces sliding friction and thereby helps to increase scuffing resistance.

Overall, through-hardened gears are used in gearboxes that require large gears that cannot be economically case hardened, such as large marine propulsion gears and railway power transmission gears.

## Case History: Design and Manufacture of a Rack

As explained in this chapter, all steel gears distort after any type of heat treat process. Carburizing imparts the highest distortion, while through hardening imparts the least distortion. Even then, distorted gears require a finishing operation for higher tooth quality. Sometimes, for through-hardened gears, the knowledge of distortion characteristics may be included in the design of gear cutting tools such that gears after heat treatment meet the desired quality. Such a case history is presented here.

The project was to develop a low-cost, high-bending strength (minimum of 250 ksi, or 1720 MPa, ultimate tensile strength) corrosion-resistant rack. For this application, the quality required was rack teeth of AGMA class 9. To minimize manufacturing cost, it was decided not to consider any post-heat-treat finishing operation. To meet these criteria, selection of a proper material and a process was vital, for which the following investigation was carried out. The dimensions and configuration of the rack are shown in Fig. 4.1.

### Material Selection

Table 4.4 shows the chemical compositions of various materials with the positive and negative attributes of each and the associated heat treat process considered before selecting the material for racks.

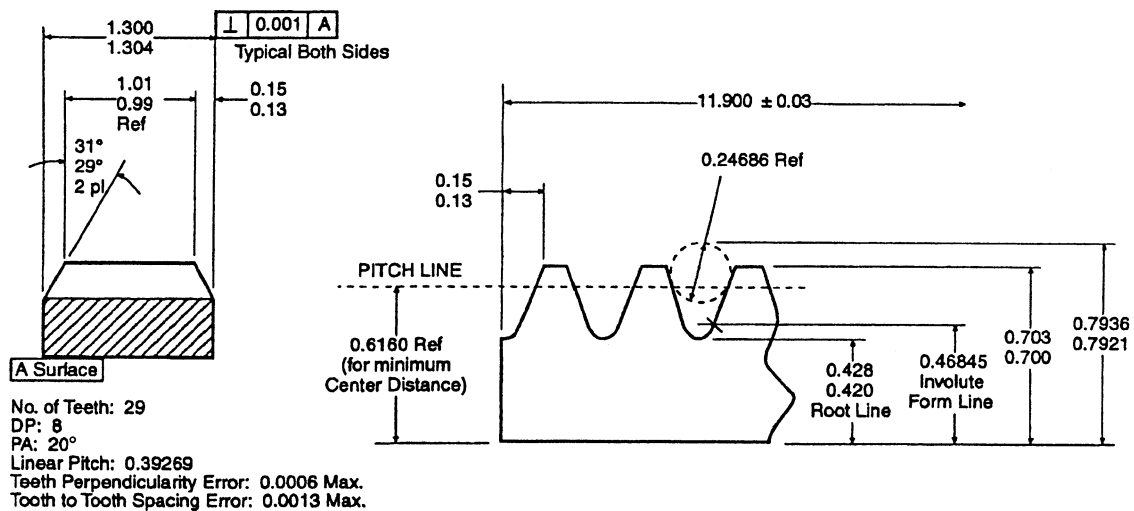


Fig. 4.1 Rack dimensions (in.) for preliminary tests. DP, diametral pitch; PA, pressure angle

**Option 1: Use of Quench-Hardening Steels.** The following steels were considered:

- AISI 4340
- 300M
- HP 9-4-30
- H-11

An excellent survey was made from published literature to determine the various properties of each, with the following results and conclusion:

*Results.* High heat treat distortion:

- Grinding of rack is necessary after heat treatment to attain the required accuracy of teeth.
- High cost of material
- Poor corrosion resistance; additional process needed to make racks corrosion resistant

*Conclusion.* None of these materials was found suitable for the application.

**Option 2: Use a Precipitation Hardening Steel.** Steels considered:

- 17-4 PH
- 13-8 Mo

*Results* were as follows:

- Attainable mechanical properties were not at specified strength level.
- Heat treat distortion was not predictable.
- Sensitive to grind burns
- Problems with alloy segregation for any post-heat treat finishing, in section size needed

*Conclusion.* Materials were not suitable.

**Table 4.4 Chemical composition of steels considered for racks**

Material	C	Mn	Si	P	S	Ni	Cr	Mo	V	Co	W	Cu
<b>Quench-hardening steels</b>												
AISI 4340	...	0.60/0.80	0.20/0.35	...	...	1.65/2.00	0.70/0.90	0.20/0.30	...	...	...	...
HP 9-4-30 <sup>(a)</sup>	0.30	0.20	0.01	0.005	0.0007	7.50	1.00	1.00	0.08	4.0	...	...
H-11	0.35	...	...	...	...	...	5.00	2.50	0.40	...	...	...
300M	0.42	0.68	1.61	0.005	0.006	1.77	0.85	0.40	0.09	...	...	...
<b>Precipitation-hardening steels</b>												
17-4 PH	...	...	...	...	...	4.00	16.50	...	...	...	...	4.00
13-8 Mo	...	...	...	...	...	8.00	12.80	2.30	...	...	...	...
<b>Age-hardening steels</b>												
Maraging C-250	0.026	0.10	0.11	...	...	18.5	...	4.30	...	7.0	...	...

(a) Courtesy Republic Steel Corporation, Cleveland, Ohio

**Option 3: Use an Age-Hardening Steel (Maraging C-250).** This maraging steel has high nickel (18% or more), very low carbon (under 0.03%), and is capable of developing very high tensile and yield strengths by means of an aging process. It is sold in the martensitic state, which, because of the low carbon, is soft enough to be readily machinable. Heating to approximately 480 °C (900 °F ) for aging, and cooling in the furnace, causes a change in material microstructure that increases the hardness up to 52 HRC. This meets the required tensile strength.

*Results* were as follows:

- Published literature indicated distortion of maraging C-250 steel is predictable.
- The material is available as forged, as well as in bar form, to AMS 6412. Sheet or plate stock available to AMS 6420 was not acceptable due to nonuniform distribution of mechanical properties.

*Conclusion.* Maraging C-250 forgings met the design requirements and were selected for this application.

### ***Process Selection***

**Heat Treat Distortion of Racks Made of C-250.** Although published literature indicated distortion of maraging C-250 material is predictable, it was still necessary to find out how much the distortion would be for a rack tooth used in this application. To determine these characteristics, a preliminary investigation was undertaken with racks made from readily available C-250 of shorter lengths (305 mm, or 12 in., long); longer lengths were not commercially available at the time of this investigation. To expedite the program further, a standard shaper cutter was used to cut the teeth. The racks were then heat treated.

**Heat Treatment of Racks.** Some preliminary experiments were conducted to select a suitable heat treat furnace. The following furnaces were considered:

- Partial vacuum furnace
- Full vacuum furnace
- Air furnace

Heat treatment in the air furnace was not acceptable due to:

- Oxidation of racks
- Scale removal resulted in size change.

Both full and partial vacuum furnaces produced oxidation-free racks.

*Conclusion.* Full vacuum furnace that ensures oxidation-free parts was selected to determine heat distortion.

Twelve racks were selected for heat treatment. All critical dimensions of the racks were inspected and recorded before heat treatment.

**The heat treat procedure** consisted of the following steps:

- Vapor degrease racks
- Wipe racks with a cleaning chemical such as acetone
- Select any two racks
- Hold the racks together back to back with nickel-plated bolts—processed horizontally on a flat base in the furnace
- Heat treat racks along with one tensile test bar in each production lot, at  $480 \pm 6$  °C ( $900 \pm 10$  °F) for 4.5 h at this temperature
- Furnace cool racks

*Inspection* consisted of:

- Critical rack dimensions after heat treatment
- Mechanical properties of material such as hardness and tensile strength

*Results.* From the experimental results and inspection, the following conclusions were made:

- Contraction rate of maraging steel was between 0.0005 and 0.0007 mm/mm (in./in.) and found to be linear and consistent in each lot.
- Parts remained flat after the hardening process.
- Pitch and accumulative pitch errors were within acceptable limit.
- Teeth perpendicularity (lead errors) were between 0.013 and 0.025 mm (0.0005 and 0.001 in.).
- Pitch dimensions measured over a pin were held to 0.038 to 0.076 mm (0.0015 to 0.003 in.).

*Recommendations* included:

- Design of rack to include 0.076 mm (0.003 in.) tolerance for pitch dimension over the pin
- Tooth perpendicularity (lead) error to 0.025 mm (0.001 in.)
- A shaper cutter to be developed to include 0.0006 mm/mm (in./in.) contraction rate of rack tooth geometry with the expectation that this might eliminate finish processing of racks after heat treatment.

**New Shaper Cutter.** With the proposed contraction rate, a shaper cutter was designed and manufactured by a cutter manufacturing company. Figure 4.2 shows the dimensions of this special cutter. An investigation was then carried out with full-length racks.

**Manufacturing method for full-length racks** consisted of the following steps:

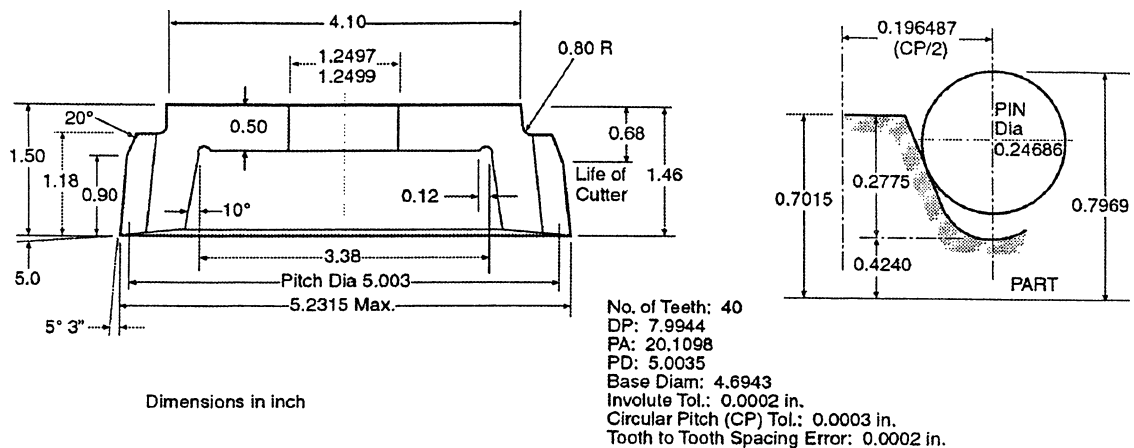
- Forge blanks
- Solution anneal to 35 HRC
- Machine (mill and drill), leaving grind stock on sliding surfaces only
- Shape rack teeth to final dimensions—rough, semifinish, and finish
- Straighten to 0.16 mm/m (0.002 in./ft)
- Inspect
- Heat treat (age) to 50 HRC—two pieces bolted back to back
- Clean
- Grind sliding surfaces locating from the pitch line of rack teeth
- Inspect all rack dimensions before and after heat treatment

*Test results* are shown in Tables 4.5 and 4.6. Analysis of the results indicates:

- Part remained flat after heat treatment within 0.25 mm (0.010 in.).
- Pitch and accumulative pitch errors were within the specified tolerance.
- Tooth perpendicularity (lead) error was within 0.025 mm (0.001 in.).
- Measurements of pitch line over the pin were within the new tolerance.

*Conclusions.* Racks met the required quality level (AGMA class 9). In this case, the modified cutter and superior heat treat facilities made it possible to manufacture the racks to AGMA class 9 without any subsequent finishing operation such as grinding.

Experiments of this nature are definitely useful in determining the distortion of heat treated gears and planning for subsequent finishing operation, if needed. When the quantity of gears to be produced is limited, and the allocated production development time is short, there may not be



**Fig. 4.2** Modified shaper cutter



many choices other than to finish the gear after heat treatment. For low distortion, honing is useful, while grinding is necessary for large distortion. However, grinding after through hardening is not recommended. Some manufacturers, instead of honing a gear and the mating pinion individually, lap the gear and pinion together with a slurry of fine abrasive compound in the mesh until the desired quality is obtained.

In general, gears designed and manufactured to AGMA class 7 and below do not require any such process development due to the fact that the hobbing or shaping process can produce gears to AGMA class 8 and above. It is expected that gears so produced will meet AGMA class 7 after heat treatment.

**Table 4.5 Experimental results: full-sized racks dimensions before heat treat**

Item	Drawing dimension	Rack 1		Rack 2	
		Left flank	Right flank	Left flank	Right flank
Linear pitch, mm (in.)	9.9746 (0.3927)	9.9720–10 (0.3927–0.3936)	9.977–9.9949 (0.3936–0.3927)	9.9771–9.9949 (0.3928–0.3935)	9.9771–9.9924 (0.3928–0.3934)
Spacing error, mm (in.)	0.0330 (0.0013) max	0.0178 (0.0007) max	0.0229 (0.0009) max	0.0203 (0.0008) max	0.0178 (0.0007) max
Accumulated spacing error, mm (in.)	0.0762 (0.003) max, over any 12 teeth	0.1778 (0.007) max	0.1778 (0.007) max	0.0152 (0.006) max	0.0152 (0.006) max
Tooth perpendicularity (lead error), mm (in.)	0.0127 (0.0005) max	0–0.0533 (0–0.0021)	0–0.0533 (0–0.0021)	0–0.0406 (0–0.0016)	0–0.0406 (0–0.0016)
Dimension over pin, mm (in.)	20.1193–20.1574 (0.7921–0.7936)	20.2946–20.7518 (0.799–0.817)	20.2946–20.7518 (0.799–0.817)	20.2692–20.5994 (0.798–0.811)	20.2692–20.5994 (0.798–0.811)
Surface finish, rms	63	≅45	≅45	≅45	≅45

**Table 4.6 Experimental results: full-sized racks dimensions after heat treat and grinding back face**

Item	Drawing dimension	Rack 1		Rack 2	
		Left flank	Right flank	Left flank	Right flank
Linear pitch, mm (in.)	9.9746 (0.3927)	9.9670–9.9873 (0.3924–0.3932)	9.9720–9.990 (0.3926–0.3933)	9.9593–9.9873 (0.3921–0.3932)	9.9670–9.9924 (0.3924–0.3934)
Spacing error, mm (in.)	0.0330 (0.0013) max	0.0152 (0.0006) max	0.0152 (0.0006) max	0.0152 (0.0006) max	0.0178 (0.0007) max
Accumulated spacing error, mm (in.)	0.0762 (0.003) max, over any 12 teeth	0.1778 (0.007) max	0.1778 (0.007) max	0.1143 (0.0045) max	0.1143 (0.0045) max
Tooth perpendicularity (lead error), mm (in.)	0.0127 (0.0005) max	0–0.0533 (0–0.0021)	0–0.0533 (0–0.0021)	0.0025–0.0279 (0.0001–0.0011)	0.0025–0.0279 (0.0001–0.0011)
Dimension over pin, mm (in.)	20.1193–20.1574 (0.7921–0.7936)	20.1016–20.1422 (0.7914–0.7930)	20.1016–20.1422 (0.7914–0.7930)	20.1270–20.1955 (0.7924–0.7951)	20.1270–20.1955 (0.7924–0.7951)
Surface finish, rms	63	≅45	≅45	≅45	≅45

# CHAPTER 5

---

---

## Carburizing and Hardening Gears

CARBURIZING is a process in which austenitized ferrous metal is brought into contact with an environment of sufficient carbon potential to cause absorption of carbon at the surface and, by diffusion, create a carbon concentration gradient between the surface and interior of the metal. The depth of penetration of carbon is dependent on temperature, time at temperature, and the composition of the carburizing agent. As a rough approximation, a carburized depth of approximately 0.76 to 1.3 mm (0.030–0.050 in.) on a 6 diametral pitch (DP) gear tooth can be obtained in about 4 h at 930 °C (1700 °F) with a carburizing agent, which may be solid, liquid, or gas.

The primary objective of carburizing and hardening gears is to secure a hard case and a relatively soft but tough core. For this process, low-carbon steels (up to a maximum of approximately 0.30% carbon), either with or without alloying elements (nickel, chromium, manganese, molybdenum), normally are used. After case carburizing, the gear teeth will have high carbon at the surface graduating into the low-carbon core.

Sometimes to prevent through hardening of the tooth tip, carbon penetration through tip of tooth needs to be controlled. This is accomplished by plating or spraying the outside diameter of gear before cutting the teeth with some material that prevents the passage of the carburizing agent. However, the most widely used method is copper plating. Several proprietary solutions and pastes, which are quite effective in preventing carburization, also are available.

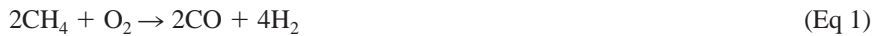
There are three general methods of carburizing, depending on the form of the carburizing medium. These methods are solid or pack carburizing, employing solid carburizing material; liquid carburizing, employing fused baths of carburizing salts; and gas carburizing, employing suitable hydrocarbon gases. The choice of the method that is used in carburizing depends mostly on the characterization of the case required, the available equipment, and the quantity of parts to be carburized. Nowadays, gears

are mostly gas carburized and, hence, this method is described in detail below.

## Gas Carburizing

---

It is estimated that 90% of gear carburizing is performed in a carbonaceous gas atmosphere. In this type of carburizing, carbon is induced into the ferrous base material heated in the gaseous atmosphere with a carbon potential that allows the surface to absorb carbon. The most commonly used medium is endothermic (commonly known as “endo”) gas produced by reacting natural gas (mainly methane, CH<sub>4</sub>) with air (1:2.5–2.7 ratio) over a heated catalyst. The important chemical reactions that take place can be expressed as:



Varying the ratio of methane to air alters the composition of endo and the chemical reactions slightly.

Free carbon resulting from chemical reaction is then dissolved in the austenite that is formed when gears are heated above 720 °C (1330 °F) and precipitates as iron carbide (Fe<sub>3</sub>C).

Recently, nitrogen-methanol has been used for supplying the carburizing atmosphere. This type of system offers a number of benefits over the conventional endo gas generator. Here, N<sub>2</sub> plays the most important function to keep air out of the furnace and prevents the gears from being oxidized. Typically, N<sub>2</sub> is more than 90% of the nitrogen-methanol atmosphere. Carburizing in nitrogen-methanol systems also ensures accurate carbon potential for improved carburized case properties. Because of higher cost with nitrogen methanol system, most of the gears are still carburized in endo gas.

### ***Carburizing Temperature***

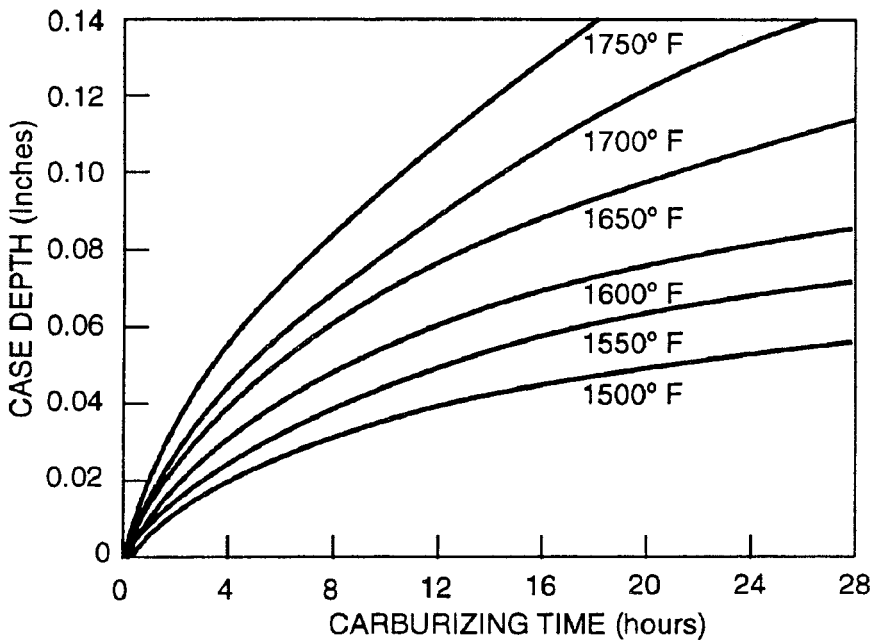
The penetration of carbon into the steel depends on the carburizing temperature, the time at temperature, and the carburizing agent. Since the solubility of carbon is greatest above the *A*<sub>c3</sub> temperature, carburization takes place most readily above this temperature. Furthermore, the higher the temperature is, the greater the rate of carbon penetration will be, since the rate of diffusion is greater. It is thus customary to select a temperature approximately 40 °C (100 °F) above the *A*<sub>c3</sub> point (Chapter 2). Again, the time at the carburizing temperature is the most influential factor in the control of the depth of carbon penetration as illustrated in Fig. 5.1.

Temperatures as low as 790 °C (1450 °F) and as high as 985 °C (1800 °F) have been used for carburizing gears, although it should be kept in mind that the life of a furnace deteriorates rapidly above 955 °C (1750 °F). With the desired amount of carbon absorbed into the tooth surface, gears are quenched in a suitable medium (generally oil) to obtain the required case hardness. Quenching may be performed either directly from the carburizing temperature or from a somewhat lower temperature. In some instances, parts after carburizing are completely cooled to room temperature, reheated to the austenitizing temperatures, and then quenched. As already mentioned, the depth of case is dependent on time and temperature selected during carburizing. The following equation generally satisfies the relationship between the case depth and carburizing time:

$$d = \varphi \sqrt{t} \dots \quad (\text{Eq 3})$$

where  $d$  is the total case depth in inches,  $t$  is the carburizing time in hours at temperature with saturated austenite at the surface, and  $\varphi$  is the proportionality factor of material that varies with the carburizing temperature.

For low carbon and alloy steels, the value of  $\varphi$  is found to be approximately 0.025 for gas carburizing at approximately 930 °C (1700°F). Thus, Eq 3 can be rewritten for most alloy steels as:



**Fig. 5.1** Depth of carbon penetration for different times and different temperatures in gas carburizing a gear steel

$$d = 0.025 \sqrt{t} \dots \quad (\text{Eq 4})$$

Another relationship used to determine  $d$  is:

$$d = \frac{31.6\sqrt{t}}{10 \left( \frac{6700}{T + 460} \right)} \quad (\text{Eq 5})$$

where  $T$  is the carburizing temperature °F. Both Eq (4) and (5) are used in industry and provide satisfactory results.

Besides time and temperature, the quality of case also depends on the type of carburizing furnace and equipment used. A proper selection is thus essential for successful carburizing and hardening.

### ***Furnaces and Equipment for Gas Carburizing***

There are three basic types of furnaces used for gas carburizing: atmospheric, vacuum, and fluidized bed. Each of these has its own advantages and disadvantages, although a great majority of gears are gas carburized in atmospheric furnaces because gas carburizing seems to offer acceptable control of case depth, surface carbon content, and diffusion of carbon into steel. The gas mixture may be adjusted to provide either a carburizing or neutral atmosphere, making it possible to diffuse the carbon in the case without the further addition of surface carbon.

**Atmospheric Furnaces.** Two types of atmospheric furnaces are used: batch and continuous. The fundamental difference between these, aside from size, is the method by which the work is handled. With a batch furnace, as the name implies, the workload is charged and discharged as a single unit or batch. With continuous furnaces, the load is fed on a continuous basis at the charged end and is received at the discharge end after processing. In a batch furnace, changes in composition of carburizing agent take place in both environment and workpieces until equilibrium is reached. In continuous furnaces, the heating chamber is divided into zones. These zones may be separated by internal doors. The atmospheres in each zone can be controlled to different carbon potentials. Coupled with different temperatures in each zone, atmosphere control provides the main means of controlling the carburizing and diffusion portion of the carburizing cycle. The chief advantage of a batch furnace is its adaptability to a variety of cycles. Each batch usually consists of several individual gears. Very large gears may be carburized one at a time; small gears may be loaded several hundred to a batch. One of the major disadvantages of this furnace is that gears are transferred from ambient temperature into a furnace usually operating at the carburizing temperature, causing thermal shock that may lead to uncontrolled distortion.

Besides atmospheric-type furnaces, carburizing also may be performed in vacuum furnaces or fluidized bed furnaces. In general, heat transfer characteristics of these furnaces are superior to atmospheric-type furnaces, assuring better case properties and uniformity of case. But the operating cost of these furnaces is much higher than atmospheric furnaces. Hence, such furnaces have limited use.

**Vacuum Furnaces.** Carburizing in a vacuum furnace is a relatively new process. Any carburizing done in an atmospheric furnace also can be accomplished in a vacuum furnace. However, vacuum carburizing offers some significant benefits in time, cost, and quality. A major reduction of time is in the heating-up phase of the process, where the parts are loaded into a cold furnace; parts and furnace are then heated up together. Furthermore, the process allows a stepped heat-up mode, which has also been found beneficial. As opposed to conventional carburizing in atmospheric furnaces, where the carburizing medium is adjusted to generate a near eutectoid surface composition, vacuum carburizing is based on a supersaturated carbon reaction.

Selecting the most suitable alloy for vacuum carburizing is very important for its success. Correct quench rates, commensurate with the alloy selection, offer a less drastic quench mode for fully hardened case and core, which atmospheric carburizing and quenching does not allow. This also results in reduced distortion of parts. The major advantage of vacuum carburizing is that it offers better control of case depth even at the root fillet of the gear tooth.

**Fluidized Bed Furnaces.** Carburizing in a fluidized bed furnace is very similar to vacuum carburizing, in that supersaturation through direct reaction with the carburizing media (natural gas, methane or propane) can take place at the surface to control the surface carbon level, together with the controlled case depth.

Details of the furnaces and equipment used in various carburizing processes are beyond the scope of this guidebook.

---

## Hardening

After carburizing, gears are quenched in a cooling medium for hardening. Quenching develops a martensitic or a bainitic case with core microstructures other than a mixture of proeutectoid ferrite and pearlite. Thus, the selection of a proper quenchant is of utmost importance, and the cooling rate, ideally, should be just fast enough to produce the desired core structure but not so fast that the case cracks or that an undue amount of austenite is retained. For industrial and automotive gears, however, quenching conditions often are chosen solely on the basis of developing required surface hardness, especially in applications where the core properties are known to have little or no effect on product performance.

Depending on part size and shape, and on transformation characteristics of the steel, gears may be quenched in water, oil, or any proprietary fluids. Most often oil is used because it is a suitable quenchant for most carburizing grades of steel, especially for relatively fine-pitch gears. Small DP gears may require a more drastic quench, particularly if densely packed, and often are susceptible to quench cracks. Regardless of the type of quenchant used, good circulation within the quench bath is extremely important to promote uniform cooling of gears.

Sometimes, for some materials, the desired properties of the case can be developed without resorting to a liquid quench, in which case air cooling, furnace cooling, or gas cooling may be appropriate. Any of these three cooling media can be used when parts are to be reheated for hardening. If intermediate operations such as straightening or machining are needed prior to hardening, furnace or gas cooling is preferred. Both are done under a protective atmosphere that keeps the gears clean and free of oxide scale and prevents decarburization of the surface.

### ***Direct Quenching***

Most gas-carburized gears are quenched directly after carburizing. Furnace temperature usually is reduced to normal austenitizing temperature (approximately 790 °C, or 1450 °F) prior to quenching. In certain cases, quenching directly from the carburizing temperature also is acceptable provided this does not induce thermal cracks in gears. On the other hand, sometimes gears made of some high-alloy steels (alloy content above 5%), are first cooled in air to room temperature after carburizing and then reheated and quenched for low distortion.

Nevertheless, direct quenching has gained wider acceptance, primarily because of economy and simplicity of the procedure. To minimize carbide network in the case, carburizing above the  $A_{cm}$  temperature is suggested. Direct quenching reduces the amount of energy used for heating and eliminates or avoids some of the equipment and operating expense of the hardening operation. Labor costs are reduced, and nicks and other part damage are minimized because the parts are handled less frequently. The use of fine-grain (ASTM 5 and above) steels, which exhibit a relatively uniform response to heat treatment, and the development of equipment and techniques for improved confidence in carbon control have led to wider acceptance of direct quenching as a means of hardening carburized gears made from a great variety of steels.

The fixtures required for adequately supporting and separating individual gears during carburizing also promote uniform direction and velocity of the quenchant movement relative to each part on the fixture. This leads to more consistent metallurgical and dimensional quality. Furthermore, a single direct-quench operation minimizes distortion by bringing about crystallographic phase changes during only one heating and one cooling cycle. Each such phase change results in volume change

of grain microstructure and increase in internal stress that may produce substantial dimensional change of a gear.

Both horizontal-batch and pusher-type continuous furnaces are well suited for direct quenching. Continuous furnaces sometimes are designed to remove one part at a time from the reduced-temperature section of the furnace for press quenching with a fixture to control distortion.

The degree of distortion in some gears, for example, varies with case depth and the amount of retained austenite in the case, as well as with alloy and process variables. Good control of carbon-gradient shape, case depth, and surface carbon content are essential for direct quenching of dimensionally sensitive gears. In case the temperature of gears is reduced prior to quenching to minimize thermal shock, carbon content near the surface must be held to below saturation; otherwise, carbides will precipitate. A grain-boundary network of carbides in the case is usually considered to be detrimental to gear life, although slow cooling after carburizing and then reheating before quench is one way to avoid or minimize the development of a carbide network.

In the case of severe quench sometimes required to obtain high core hardness, the shape of the gear section being quenched is of great importance since a combination of thick and thin sections (for example, annulus of epicyclic gearbox) may lead to cracking. Cracking results due to a difference in the rate of cooling of thick and thin sections. The transformation of thicker sections will take place when the thin sections are at a lower temperature. The expansion in the thick sections on transformation will set up very high stress concentrations, which may cause warpage or cracking. If proper core hardness cannot be achieved for a certain gear tooth size, an alternate material needs to be investigated.

### ***Reheating of Carburized Gears and Quenching***

Originally, only high-alloy steels were carburized, because of the relatively unsophisticated steel-producing techniques required for alloy additions to yield a steel with uniform response to heat treatment. At that time, carburizing was done only by pack carburizing, which has a different set of material-handling and carbon-control techniques than does gas carburizing. The original carburizing grade steels, which were high in nickel, required a reheat operation after pack carburizing to produce a uniform microstructure in the case. Reheating was also the only effective method of reducing the surface carbon content below saturation. Later, although low-alloy steels were introduced for gears, pack carburizing or crude gas-carburizing techniques still required gear reheating to control surface carbon and microstructure. Today, the modern carburizing equipment is capable of producing the desired microstructure in the case of both high- and low-alloy steels. Even then, certain types of gear steels are still reheated before quenching to ensure the quality of case microstructure and low distortion.



Gears requiring individual quenching in a fixture sometimes are reheated as a practical means of confining the tedious one-at-a-time hardening operation to a few simple hardening furnaces, while a larger, more-expensive continuous carburizing furnace is permitted to operate at its maximum capacity for direct quench. Sometimes, the total cost including labor and fuel can be lower for a carburize, cool, and reheat procedure than for direct quenching. Also, this technique of carburizing, followed by slow cooling, machining certain areas to remove the case, and then hardening the entire gear sometimes is used when selected areas must be free of a carburized hardened case.

Furthermore, reheating of gears occasionally is specified for “grain refinement.” However, there is considerable disagreement over the advantage of a reheated microstructure over a direct-quenched microstructure, and whether the former is preferred because of tradition, or because of a real need, is unknown. The amount of retained austenite is usually lower, or at least is less visible in microstructures of reheated gears. Again, the effect of retained austenite on gear performance is controversial, but clearly it is not always detrimental. Also, if reheating is used, there is always the danger of greater thermal distortion. The choice between direct quenching, and reheating and quenching should often be decided on the basis of a specific application. Reheating generally is recommended only after high-temperature carburizing (above 930 °C, or 1700 °F).

### ***Surface Hardness Variations after Quenching***

Variation in the surface hardness of gears within a lot is a problem that is often encountered when many small gears are heat treated in the same basket. This variation is due to the parts being too densely loaded, especially at the center of the load. This restricts the flow of quenchant in such a manner that gears near the basket’s perimeter may attain full surface hardness while those in the center do not. If it is not possible to space out the gears for economic reasons, at least divider screens should be inserted to “layer” the load.

Another possible cause of gear surface hardness variation in a lot is insufficient quench bath agitation. The obvious solution is to speed up the circulation system of the quench tank in order to move more quenchant through the load faster. Approximately 230 to 260 L/min (60–70 gal/min) of gear is considered an ideal rate. This establishes the rate of cooling to touch the nose of S-curve (Fig. 2.7) for ideal martensitic transformation of most gear steels.

## **Tempering of Carburized and Quenched Gears**

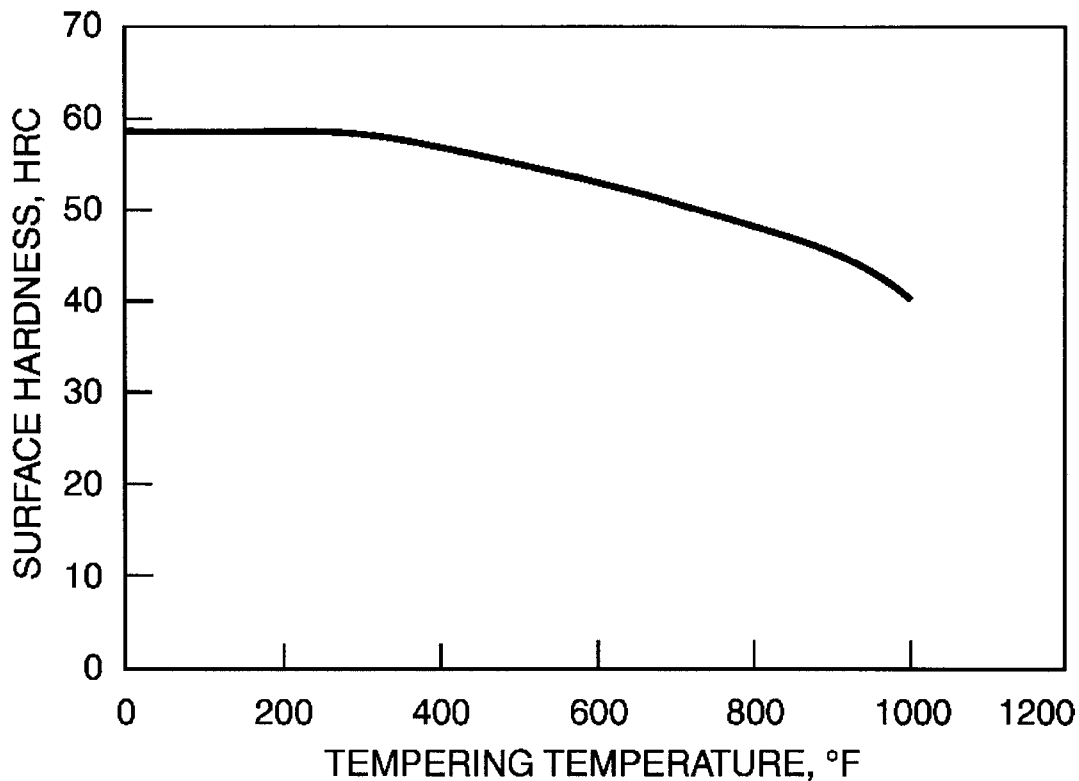
---

Tempering is a process of reheating quench-hardened gears to a temperature below the transformation range of steel and holding at this

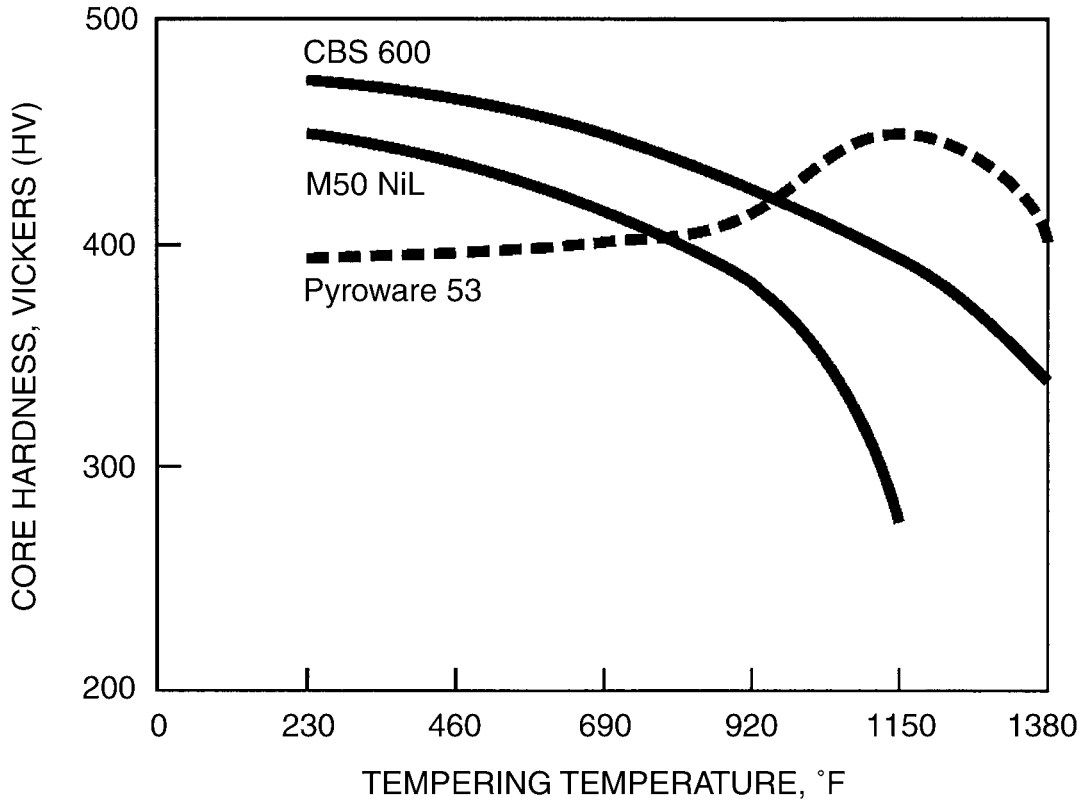
temperature to reduce thermal stresses induced during quenching and improve dimensional stability. Normal tempering temperature for carburized and quenched gears varies between 115 and 175 °C (240 and 350 °F). The surface hardness of quenched gears decreases as the tempering temperature increases as shown in Fig. 5.2. In addition, tempering temperature has a significant effect on core hardness, as illustrated in Fig. 5.3. Furthermore, higher tempering temperatures reduce both case hardness and case depth. In applications where gears are required to maintain high compressive and bending strengths at an elevated temperature, carburizing steels that are least affected by tempering temperature are preferred.

To enhance the effect of tempering, it should follow soon after the quench but not until the gears can be comfortably touched with bare hands. Tempering too early can cause serious problems by interrupting the martensitic transformation. To the other extreme, too long a delay before tempering might create a major distortion problem and even cracking of the gears.

Tempering is a necessary finishing treatment after hardening. However, it also involves heating and cooling. This may again generate new stresses



**Fig. 5.2** Variation of tooth surface hardness with tempering temperature of carburized and hardened AISI 8620H gears



**Fig. 5.3** Influence of tempering temperature on core hardness of some high alloy steels

in the gears being processed. Fortunately, the influence of these new stresses on geometric shapes of gears is very small due to low temperature levels involved. Nevertheless, uniform heating and cooling is advisable during tempering to keep distortion-causing stresses at a minimum.

Some controversy still exists concerning the value of tempering carburized and quenched gears. For critical applications, experience has proved that tempering is definitely beneficial. Carburized and hardened gears used in aerospace applications invariably need to be tempered. The reasoning is that tempering is not harmful and provides some benefit to resist cracking or chipping of gears under edge loading. However, in thousands of other less critical applications, it is difficult or sometimes impossible to prove the need of a tempering operation for carburized and hardened gears.

## Recarburizing

Occasionally after carburizing and hardening, gears in a certain lot are found to have lower surface carbon and case depth even when all the

furnace carburizing parameters are kept the same. To salvage these under-carburized gears by recarburizing sometimes creates a number of potential problems. For example:

- Every time a gear is heated, there is more distortion.
- If a hardened gear is charged into a hot furnace, it might crack.
- If the carburized case depth is shallow, carburizing the second time will increase case carbon content.

This also can result in excessive retained austenite or an undesirable carbide network. Thus, all scenarios are to be considered before recarburizing gears.

## Cold Treatment

---

The presence of retained austenite in a heat treated case can be the source of dimensional instability, excessive residual stress, or cracking, all of which may cause service problems with a carburized gear. Retained austenite is more prominent at high surface carbon and alloy contents, and in cases where gears have been direct quenched from high carburizing temperatures rather than cooled, reheated, and quenched. High-carbon and high-alloy contents in steels depress the temperatures at which martensitic transformation begins and ends. In some instances, the transformation temperature may be well below room temperature, which favors the retention of large amounts of austenite.

One way of reducing the amount of retained austenite in the case microstructure is to cold treat a gear following quenching. Cold treatment is basically a continuation of quenching, during which retained austenite in the case is transformed to martensite. The percentage of transformation is related to temperature rather than to time at a temperature—lower temperatures yield higher levels of transformation. Multiple treatments produce diminishing improvement. Almost all of the significant transformation is achieved by the first cold treatment.

The specific amount of martensitic transformation achieved by a given subzero treatment is extremely difficult to predict. The degree of reluctance to transform at a given temperature is influenced by:

- The amount of retained austenite at the start of cold treatment
- The elapsed time between quenching and cold treating
- Any intermediate thermal treatment, such as tempering
- The general level of residual compressive stress in the part
- Any cold working of the material, such as straightening of long slender pinions after carburizing and quenching

Temperatures in the range  $-75$  to  $-100$  °C ( $-100$  to  $-150$  °F) are routinely used in cold treating. Equipment for cold treatment up to  $-75$  °C ( $-100$  °F) can be as simple as dry ice mixed with kerosene, trichloroethylene, or alcohol in a bucket. Temperatures down to  $-100$  °C ( $-150$  °F) is reached with relatively simple mechanical refrigeration. Liquid nitrogen can be used for chilling to any temperature down to  $-195$  °C ( $-320$  °F) but is seldom used.

## Selection of Materials for Carburized Gears

There is a wide variety of carburizing grade materials that offer different mechanical properties (Table 5.1a). Heat treat data for some of these steels are given in Table 5.1(b). In general, a material that can attain a tooth surface hardness around 60 HRC and a core hardness between 32 and 48 HRC after carburizing and hardening is selected. The choice determines the surface case and core hardnesses. A low surface hardness of tooth reduces the pitting life of gears. On the other hand, low core hardness reduces bending fatigue life. As already discussed, the surface hardness of a gear tooth is strictly dependent on the percentage of carbon at the surface, whereas the core hardness is related to the hardenability of

**Table 5.1(a) Chemical compositions of frequently used carburizing grade gear steels, %**

Material (AISI)	C	Mn	P	S	Si	Ni	Cr	Mo	V	W	Co
3310	0.08–0.13	0.45–0.60	0.025 max.	0.025 max.	0.20–0.35	3.25–3.75	1.40–1.75	...	...	...	...
3310H	0.07–0.13	0.30–0.70	0.035 max.	0.040 max.	0.20–0.35	3.20–3.80	1.30–1.80	...	...	...	...
4023	0.20–0.25	0.70–0.90	0.035 max.	0.040 max.	...	...	...	0.20–0.30	...	...	...
4027	0.25–0.30	0.70–0.90	0.035 max.	0.040 max.	...	...	...	0.20–0.30	...	...	...
4118	0.18–0.23	0.70–0.90	0.035 max.	0.040 max.	0.20–0.35	...	0.40–0.60	0.08–0.15	...	...	...
4118H	0.17–0.23	0.60–1.00	0.035 max.	0.040 max.	0.20–0.35	...	0.30–0.70	0.08–0.15	...	...	...
4140	0.38–0.43	0.75–1.00	0.035 max.	0.040 max.	0.20–0.35	...	0.80–1.10	0.15–0.25	...	...	...
4320	0.17–0.22	0.45–0.64	0.035 max.	0.040 max.	0.20–0.35	1.65–2.00	0.40–0.60	0.20–0.30	...	...	...
4330M	0.30–0.33	0.96	0.008 max.	0.006	0.30	1.82	0.88	0.44	0.09	...	...
4620	0.17–0.22	0.45–0.65	0.035 max.	0.040 max.	0.20–0.35	1.65–2.00	...	0.20–0.30	...	...	...
4815	0.13–0.18	0.40–0.60	0.035 max.	0.040 max.	0.20–0.35	3.25–3.75	...	0.20–0.30	...	...	...
4820	0.18–0.23	0.50–0.70	0.035 max.	0.040 max.	0.20–0.35	3.25–3.75	...	0.20–0.30	...	...	...
8617	0.15–0.20	0.70–0.90	0.035 max.	0.040 max.	0.20–0.35	0.40–0.70	0.40–0.60	0.15–0.25	...	...	...
8617H	0.14–0.20	0.60–0.95	0.035 max.	0.040 max.	0.20–0.35	0.35–0.75	0.35–0.65	0.15–0.25	...	...	...
8620	0.18–0.23	0.70–0.90	0.035 max.	0.040 max.	0.20–0.35	0.40–0.70	0.40–0.60	0.15–0.25	...	...	...
8620H	0.17–0.23	0.60–0.95	0.035 max.	0.040 max.	0.20–0.35	0.35–0.75	0.35–0.65	0.15–0.25	...	...	...
8720	0.18–0.23	0.70–0.90	0.035 max.	0.040 max.	0.20–0.35	0.40–0.70	0.40–0.60	0.20–0.30	...	...	...
8822H	0.19–0.25	0.70–1.05	0.035 max.	0.040 max.	0.20–0.35	0.35–0.75	0.35–0.65	0.30–0.40	...	...	...
9310	0.08–0.13	0.45–0.65	0.025 max.	0.025 max.	0.20–0.35	3.00–3.50	1.00–1.40	0.08–0.15	...	...	...
HP9-4-30	0.30	0.20	0.005	0.007	0.01	7.50	1.00	1.00	0.08	...	4.0
Pyrowear	0.10	0.37	...	...	...	2.15	1.05	3.30	0.12	...	...
17CrNiMo6	0.14–0.19	0.40–0.80	0.125 max.	0.005–0.020	0.15–0.35	1.40–1.70	1.50–1.80	0.25–0.35	0.06 max.	...	...
VASCO X2M	0.15	0.30	0.15 max.	0.01 max.	0.90	...	5.0	1.40	0.45	...	1.35
M50NiL	0.15	0.25	...	...	...	3.5	3.5	4.0	1.0	...	...
EX 30	0.13–0.18	0.70–0.90	0.04	0.04	0.20–0.35	0.70–1.00	0.45–0.65	0.45–0.60	...	...	...
EX 55	0.15–0.20	0.20–1.00	0.04	0.04	0.20–0.35	1.65–2.00	0.45–0.65	0.45–0.80	...	...	...

the material and is determined by the alloying elements in the steel. It is thus essential to have a clear understanding of the terms *hardness* and *hardenability* of gear materials. Metallurgically, these two terms are quite different from one another as discussed subsequently.

### Hardness and Hardenability

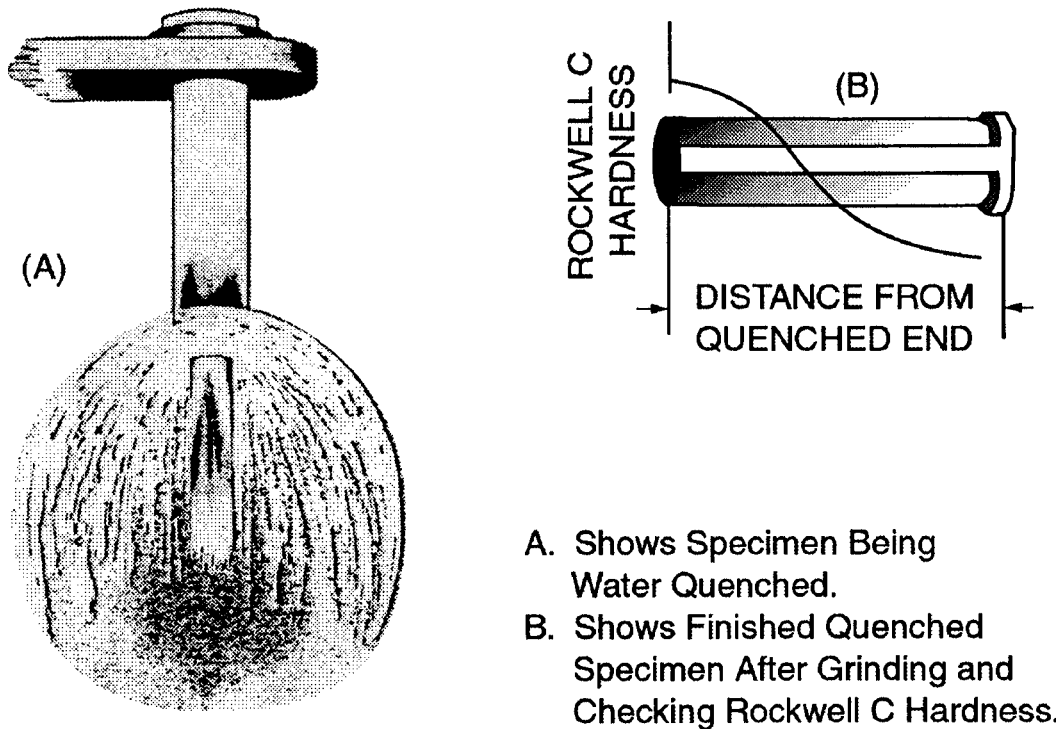
Hardness is a surface property, whereas hardenability of steels refers to depth and hardness distribution induced by quenching. Steels with low hardenability can be hardened to a relatively shallow depth. In these types of steels, austenite-martensite transformation takes place in the area close to the surface only. The center of heat treated section remains soft or transforms to a structure softer than martensite, such as pearlite. Steels with high hardenability develop a much deeper martensitic structure when similarly treated.

As explained previously, the higher the surface carbon is, the higher the surface hardness will be until surface carbon reaches around 0.6%. To increase hardenability of steels the chemical compositions of steels need to be altered to slow down martensitic transformation. This is achieved by alloying the steels. All alloying elements, except cobalt, increase hardenability of steels. The common method to determine hardenability is by the Jominy, or end-quench, test where a test bar of the steel, 25 mm (1 in.) in diameter by 100 mm (4 in.) long, normalized and machined to remove the decarburized surface, is heated to the hardening temperature for 30 minutes (Fig. 5.4a). It is then quickly transferred to a fixture that holds the

**Table 5.1(b) Heat treating data for some gear steels**

AISI No.	Normalizing temperature, °C (°F)	Annealing temperature, °C (°F)	Hardening temperature, °C (°F)	Carburizing temperature, °C (°F)	Reheat temperature, °C (°F)	$M_s$ temperature(a), °C (°F)
3310	900–950 (1650–1750)	860 (1575)	775–800 (1425–1475)	900–930 (1650–1700)	790–815 (1450–1500)	350 (655)
3140	815–930 (1500–1700)	790–840 (1450–1550)	815–840 (1500–1550)	...	...	310 (590)
4028	870–930 (1600–1700)	830–860 (1525–1575)	...	870–930 (1600–1700)	790–815 (1450–1500)	400 (750)
4047	840–950 (1550–1750)	830–860 (1525–1575)	800–840 (1475–1550)	...	...	...
4130	870–930 (1600–1700)	790–840 (1450–1550)	840–900 (1550–1650)	...	...	365 (685)
4140	870–930 (1600–1700)	790–840 (1450–1550)	830–885 (1525–1625)	...	...	315 (595)
4320	870–930 (1600–1700)	860 (1575)	...	900–930 (1650–1700)	775–800 (1425–1475)	380 (720)
3440	870–930 (1600–1700)	590–660 (1100–1225)	800–830 (1475–1525)	...	...	285 (545)
4620	930–980 (1700–1800)	860 (1575)	...	900–930 (1650–1700)	800–830 (1475–1525)	290 (555)
4640	870–930 (1600–1700)	790–840 (1450–1550)	790–840 (1450–1550)	...	...	320 (605)
4820	900–950 (1650–1750)	875 (1575)	...	900–930 (1650–1700)	790–815 (1450–1500)	365 (685)
5145	870–930 (1600–1700)	790–840 (1450–1550)	800–830 (1475–1525)	...	...	...
6120	930–980 (1700–1800)	870 (1600)	...	930 (1700)	775–800 (1425–1475)	400 (760)
6150	900–950 (1650–1750)	840–900 (1550–1650)	840–900 (1550–1650)	...	...	285 (545)
8620	870–930 (1600–1700)	860 (1575)	...	930 (1700)	775–840 (1425–1550)	395 (745)
9310	900–950 (1650–1750)	860 (1575)	...	900–930 (1650–1700)	775–840 (1425–1550)	345 (650)
EX 24	900–950 (1650–1750)	870 (1600)	870 (1600)	900–930 (1650–1700)	815–840 (1500–1550)	445 (830)
EX 29	900–950 (1650–1750)	870 (1600)	870 (1600)	900–930 (1650–1700)	815–840 (1500–1550)	445 (830)
EX 30	900–950 (1650–1750)	840 (1550)	870 (1600)	900–930 (1650–1700)	815–840 (1500–1550)	445 (830)
EX 55	900–950 (1650–1750)	830 (1525)	870 (1600)	900–930 (1650–1700)	815–840 (1500–1550)	420 (790)

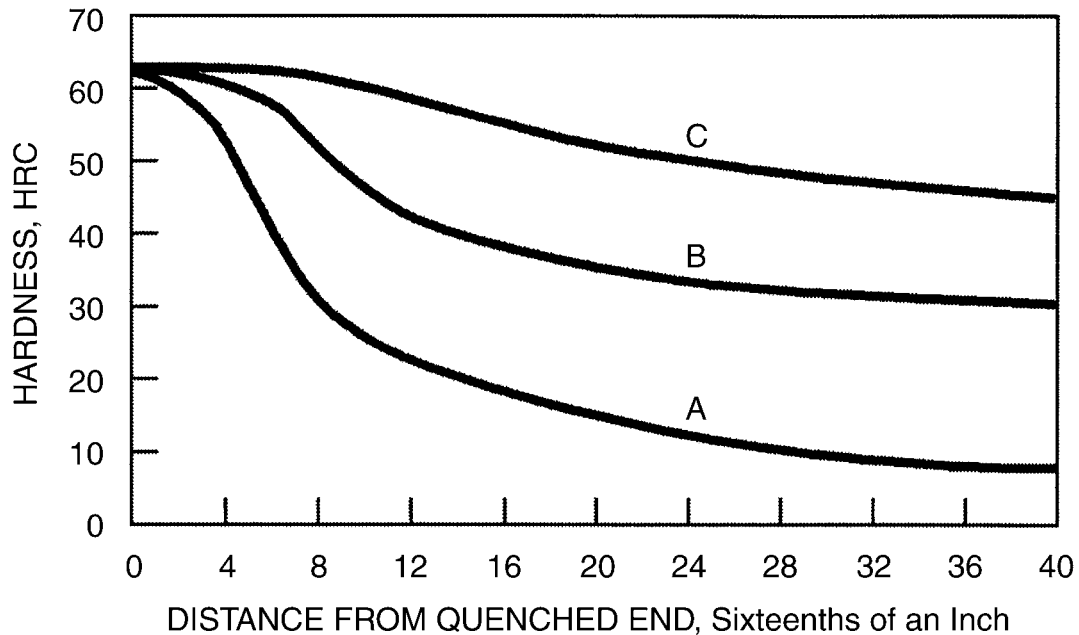
(a)  $M_s$  is the temperature at which martensite forms.



**Fig. 5.4(a)** End quenching and method of hardness testing the end-quench hardenability specimen. Courtesy of Republic Steel Corporation, Cleveland, Ohio

bar in a vertical position, and a jet of water under controlled conditions is directed immediately against the bottom end only. The end of the bar is thus cooled very quickly while cross sections remote from the end are cooled more slowly. The rate of cooling is dependent on the distance from the quenched end. After the cooling is completed, two diametrically opposite flats approximately 6 mm ( $\frac{1}{4}$  in.) wide are ground along the length of the bar and Rockwell hardness measurements are made at intervals of 1.6 mm ( $\frac{1}{16}$  in.), on one or both the flat surfaces so prepared. The relationship of hardness to distance from the quenched end is an indication of the hardenability of steel (Fig. 5.4b).

Carbon content in alloy steels also plays an important role in developing hardenability. Figures 5.5(a) and 5.5(b) show hardenability curves for some materials with different content of carbon. The degree of hardness at the quenched end (surface) depends primarily on the carbon content, but the hardness at any point away from this end depends on the alloy content in the steel as well as carbon. Deep-hardening steels produce flatter hardenability curves. Commercially available "H-band" steels assure high hardenability. Producers of such steels usually indicate minimum and maximum hardnesses that are expected at any depth from the quenched end of the bar.



**Fig. 5.4(b)** Hardenability curves for different steels with the same carbon content. A, shallow hardening; B, intermediate hardening; C, deep hardening

**Effect of Common Alloying Elements on Hardness and Hardenability.** There are five fundamental factors that influence hardenability of steel:

- Mean composition of the austenite
- Homogeneity of the austenite
- Grain size of the austenite
- Nonmetallic inclusions in the austenite
- Undissolved carbides and nitrides in the austenite

It has been found that the effect of dissolved elements that combine with carbon in preference to dissolving in ferrite have the greatest influence in increasing hardenability if they are dissolved in the austenite before quenching. A carbide-forming element that is not dissolved in the austenite has no effect on hardenability except that as a carbide it may restrict grain growth, thus reducing the hardenability of the steel. Undissolved carbides reduce both the alloy and carbon content of the austenite. Since undissolved carbides restrict grain growth, in some instances, quenching from higher temperature that increases grain size promotes deeper hardening. In summary, the factors that increase hardenability are:



- Dissolved elements in austenite (except cobalt)
- Coarse grains of austenite
- Homogeneity of austenite

The factors that reduce hardenability are:

- Fine grains of austenite
- Undissolved inclusions
  - a. Carbides or nitrides
  - b. Nonmetallic inclusions

Of the various alloying elements used in commonly used gear materials, the following are considered to affect tooth surface and core hardnesses significantly:

- *Nickel (Ni)*: The principal advantage lies in higher tensile strength that can be obtained without appreciable decrease of elongation and reduction area. Nickel also lowers the critical temperatures, and hence, lower heat treat temperature can be used. It decreases the critical cooling rate; therefore, a less rapid quench is required to obtain

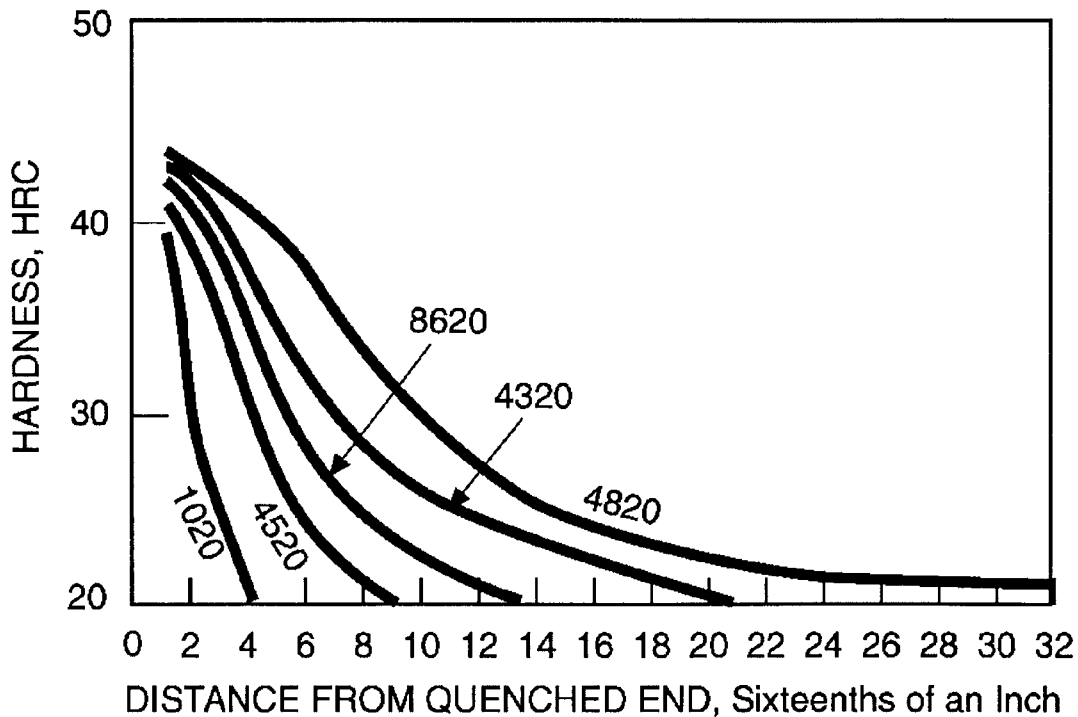
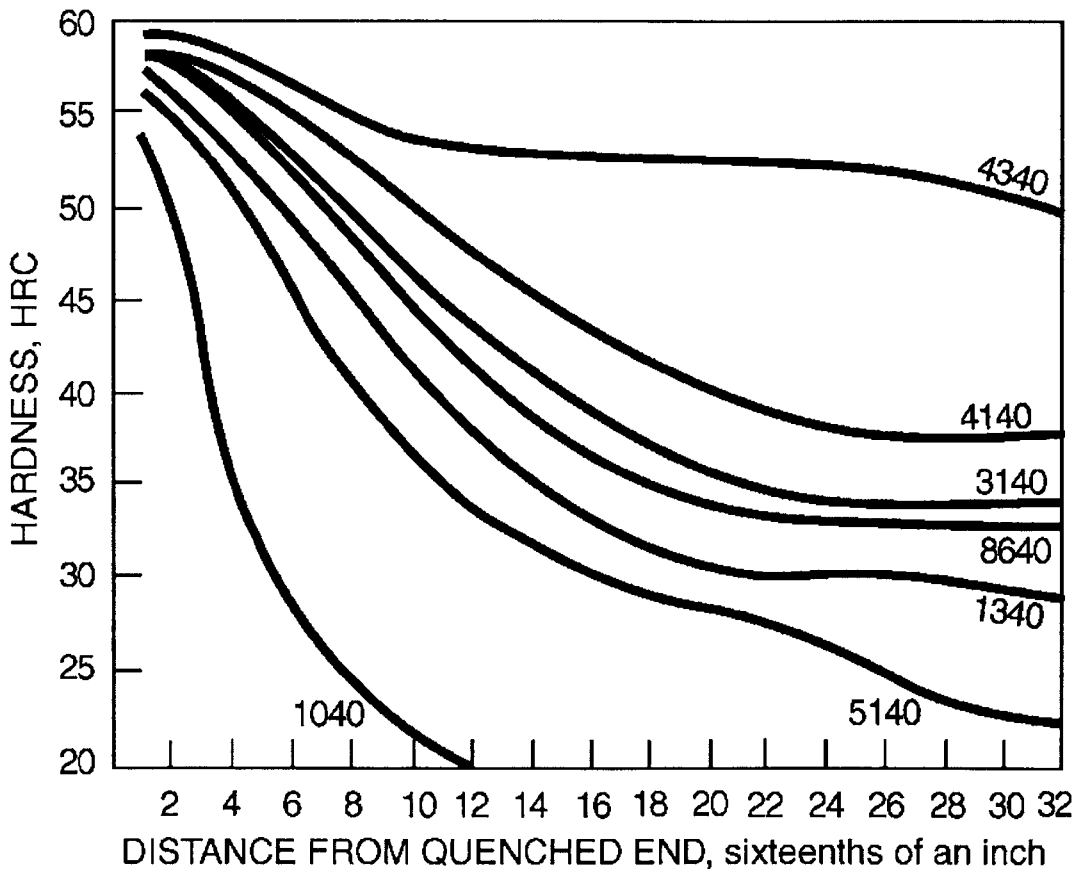


Fig. 5.5(a) Comparative hardenability of 0.20% carbon AISI alloy steels

hardness equal to that of plain carbon steel. Nickel increases hardenability and fatigue strength of steels.

- *Chromium (Cr)*: It is essentially a hardening element and frequently used with other elements such as nickel to improve strength and wear resistance and hardenability. Chromium has, however, the disadvantage of being temper brittle, and hence, precautions must be taken when tempering in the range above 540 °C (1000 °F).
- *Molybdenum (Mo)*: The pronounced effects of molybdenum when added in relatively small amounts (0.15–0.3%) are:
  - a. Greater ductility and toughness
  - b. Reduced temper brittleness
  - c. Improved creep resistance at high temperatures
  - d. Greater hardenability when present with chromium
- *Vanadium (V)*: When present with nickel, chromium, and molybdenum, vanadium:
  - a. Improves fatigue resistance
  - b. Provides fine grain structure



**Fig. 5.5(b)** Comparative hardenability of 0.40% carbon AISI alloy steels

- c. Reduces grain-growth tendencies
- d. Improves hardenability only when quenched from higher temperature
- *Tungsten (W)*: Tungsten forms a hard, stable carbide that imparts wear and abrasive resistance. In the dissolved form, tungsten increases hardenability. In certain combinations with chromium and vanadium, tungsten decreases the tendency to form cracks in case-core boundary, and distortion during heat treatment.
- *Cobalt (Co)*: Cobalt improves high temperature strength characteristics and corrosion resistance. In addition, it imparts excellent wear resistance. But, the hardenability of steel is reduced with cobalt over 0.4%.

**Selection of Gear Steel by Hardenability.** Since there is a variety of steels with standard and nonstandard analyses, the problem of selecting just the right steel for a certain application can become quite confusing if chemistry comparisons alone are used. The establishment of end-quench hardenability curves demonstrates how alloys slow down the reaction rates of steels. Also, mass has significant influence on hardenability. The rate of heat transfer is not uniform for gears with varied cross sections. Larger gears (heavier mass) experience more nonuniform heat transfer. There is danger of cracking large gears if they are quenched drastically enough to harden completely. A milder quench, on the other hand, may not develop microstructures with the required strength. In extreme cases, the part may be so large that even with considerable alloy content, it is not practical to use a fast enough quench to develop full hardness. In these cases, a gear designer needs to compromise by designing with low allowable stresses to get by with the properties that can be obtained in the steel after heat treatment. Figure 5.6 shows end-quench hardenability curves for several kinds of gear steels frequently used in industrial and aerospace applications.

Table 5.2 presents core hardness of some carburized steels of different diameter sections. This table also shows how the tensile properties of the specimens vary with size.

---

## Carbon Content and Case Property

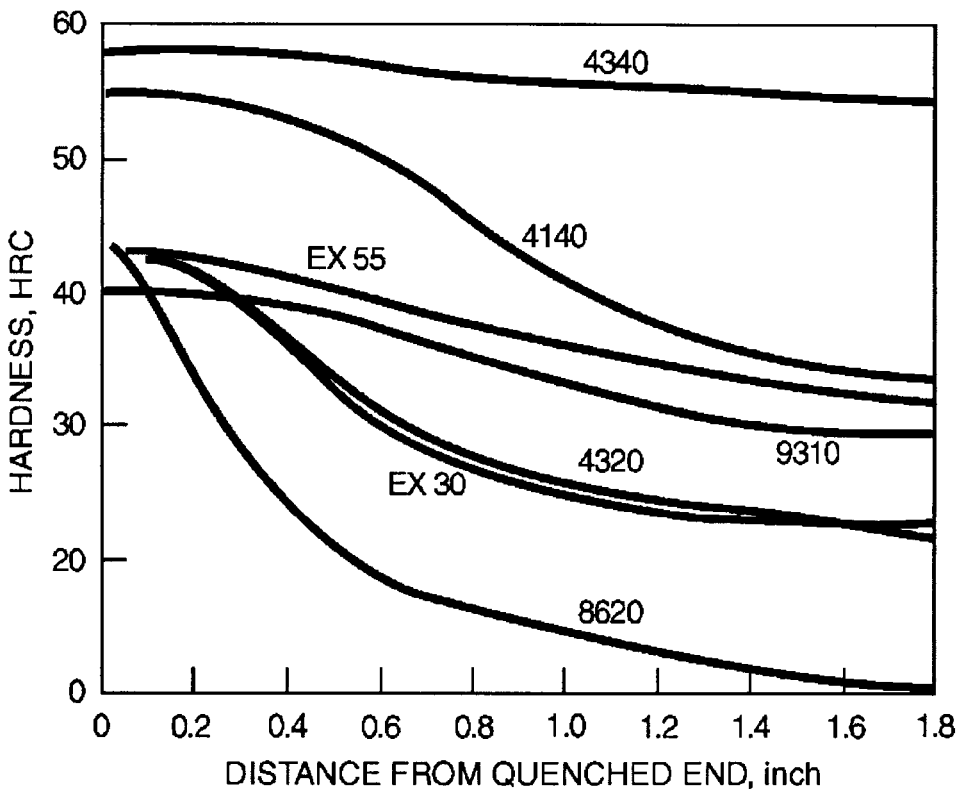
---

A carburized gear tooth may be regarded as a composite structure consisting of a low carbon in the core and a high carbon of the same steel composition at the surface.

Increasing the carbon content of the case (within limits) increases wear resistance and resistance to contact fatigue. As the carbon level increases above 0.8%, there is a tendency to retain austenite and to produce carbide networks in the case. Heavy carbide networks can produce brittle cases, leading to tooth end chipping. It has been shown that a level of 15 to 20%

retained austenite is desirable both for sliding wear resistance and resistance to pitting fatigue. Excessive retained austenite causes soft cases and lowers surface hardness and should be avoided. Moderate quantities of retained austenite transform and work harden under the contact load. A carbon level in the range 0.9 to 1.0% (for low-alloy steels) at the surface generally gives the optimum case properties to resist contact fatigue and surface wear. Similar case properties in high-alloy steels may be obtained with lower carbon level.

**Case Depth of Tooth.** Case depth is an important parameter of carburized and hardened gears and plays a significant role in determining their pitting fatigue life. The case must be sufficiently deep to resist case crushing by the applied load on the gear. In general, case depth of a carburized tooth is a function of diametral pitch. The bigger the tooth, the more case is needed to carry the loads that will be imposed on the tooth. For each size of tooth there is an optimum case depth. Too much case makes a tooth brittle with the tendency to shatter off the top of a tooth. However, too thin a case reduces tooth resistance to pitting. A high-hardenability steel with strong core structure may not need a deep case as with a lower hardenability steel. This makes it difficult to calculate an



**Fig. 5.6** Some typical Jominy curves showing end-quench hardenability. Courtesy: Darle Dudley, *Handbook of Practical Gear Design*, Technomic Publishing Co., Inc.

optimum case depth with complete certainty for all types of steels. A further practical point is that case depths vary according to the heat treatment cycle and equipment used. For example, in a batch-type furnace where a load is made up of a large number of densely packed gears there will be a variation in case depth throughout the load. This is due to variations in temperature and carburizing atmosphere circulation. Using a lower temperature for carburizing, much better control over case depth is possible. At a temperature of 900 °C (1650 °F), it is not unrealistic to expect a case depth tolerance of 0.08 to 0.15 mm (0.003–0.006 in.).

**Measurement of Case Depth.** In the gear industry, two terms are frequently used to determine the quality of a carburized case—total case depth and effective case depth. Thus, an accurate and repeatable method for measuring these case depths on a gear tooth is essential not only to control the reliability of carburizing process but also for evaluation of gear performance. The total case depth is the perpendicular distance from the surface of a carburized and hardened tooth to a point inside the tooth at which difference in chemical and mechanical properties of the case and core can no longer be distinguished. Effective case depth, on the other hand, is the perpendicular distance from the surface to the farthest point inside the tooth at which a hardness of 50 HRC is measured. To measure case depths, a mechanical method is considered to be one of the most useful and accurate of all the methods available. In this method, for gears

**Table 5.2 Effect of section size on core hardness and tensile properties of carburized steels**

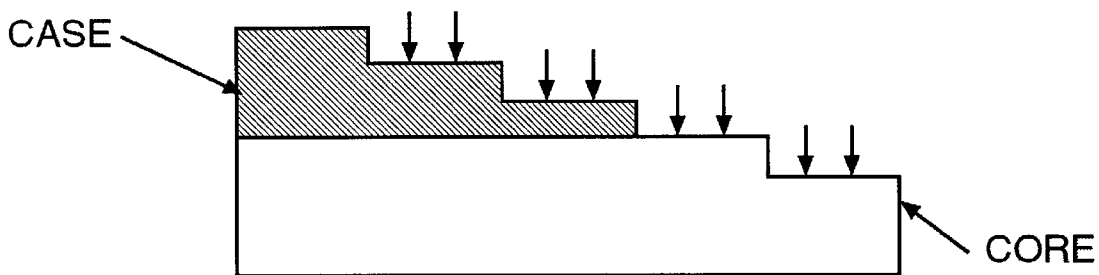
Steel type, AISI	Heat treatment		Bar diam, mm (in.)	Core hardness, HB	Tensile properties			
	Quenching temperature of oil, °C (°F)	Tempering temperature, °C (°F)			Tensile strength, MPa (ksi)	Yield strength, MPa (ksi)	Elongation, %	Reduction of area, %
4320	815 (1500)	150 (300)	13 (½)	415	1055 (153)	1124 (163)	12	46
			25 (1)	302	738 (107)	738 (107)	17	51
			50 (2)	255	593 (86)	593 (86)	22	56
			102 (4)	248	517 (75)	517 (75)	24	57
4620	815 (1500)	150 (300)	13 (½)	255	876 (127)	621 (90)	20	60
			25 (1)	197	676 (98)	462 (67)	26	70
			50 (2)	192	662 (96)	448 (65)	27	70
			102 (4)	170	586 (85)	359 (52)	30	69
4820	800 (1475)	150 (300)	13 (½)	401	1441 (209)	1193 (173)	14	54
			25 (1)	352	1172 (170)	869 (126)	15	51
			50 (2)	277	938 (136)	641 (93)	20	56
			102 (4)	241	820 (119)	558 (81)	23	59
			152 (6)	226	765 (111)	517 (75)	22	62
8620	845 (1550)	150 (300)	13 (½)	388	1379 (200)	1082 (157)	13	49
			25 (1)	255	876 (127)	579 (84)	21	53
			50 (2)	235	807 (117)	503 (73)	23	58
			102 (4)	207	676 (98)	400 (58)	24	58
			152 (6)	200	655 (95)	400 (58)	24	64
9310	790 (1450)	150 (300)	13 (½)	363	1234 (179)	986 (143)	16	59
			25 (1)	321	1096 (159)	848 (123)	16	58
			50 (2)	293	1000 (145)	745 (108)	18	67
			102 (4)	277	938 (136)	655 (95)	19	62

in critical applications, a cross section of a representative tooth from a pie-shaped test coupon prepared from the same “heat” of steel is preferred for reliability. However, for vacuum melt steels with cleanliness of AMS 2300 or 2304, the test coupon does not necessarily have to be made from the same heat of steel to ensure a similar reliability of case microstructure. Nevertheless, considerable care should be exercised in preparing such a specimen. The tooth needs to be sectioned perpendicular to the hardened surface. Cutting or grinding that would affect the original hardness is to be avoided. Polishing of the specimen is quite important. This polishing should be done finely enough so that hardness impressions are unaffected. A Tukon (Wilson Instruments, Div. of Instron Corp., Canton, MA) type microhardness tester is recommended for case-depth measurements.

In noncritical gears, case depths are determined by step grinding (0.13 mm, or 0.005 in., step) a test coupon of rectangular cross section as illustrated in Fig. 5.7. Here, the hardness readings are taken on steps that are of known distances below the carburized surface, and a standard Rockwell hardness tester may be used. At a particular step, if the hardness is found to be greater than 50 HRC and less than 50 HRC on the next deeper step, the effective case depth is taken to be between the two depths.

Figure 5.8 illustrates typical hardness versus case depth readings taken at pitch line and root fillet of a carburized and hardened gear tooth. The effective case depth at root fillet area is always somewhat lower than at the pitch line. In a gear, the effective case depth at pitch line is of importance for gear pitting life, and hence, the value at this line is regarded as the effective case depth of a gear tooth. Case depth in root fillet contributes to higher bending fatigue life.

**Effective Case Depth of High-Alloy Steel Gears.** Hardness versus case depth relationship as depicted in Fig. 5.8 applies to low- to medium-alloy steels such as AISI 8620, 4320, and so on. In high-alloy steels such as HP 9-4-30, AISI 4330M, the core hardness after carburizing and hardening may be as high as 52 HRC. For this type of steels, effective case depth cannot be determined as already outlined. Typical hardness versus case depth for a high-alloy and high core hardness steel (HP 9-4-30) is shown in Fig. 5.9. For such steels, 55 HRC instead of 50 HRC



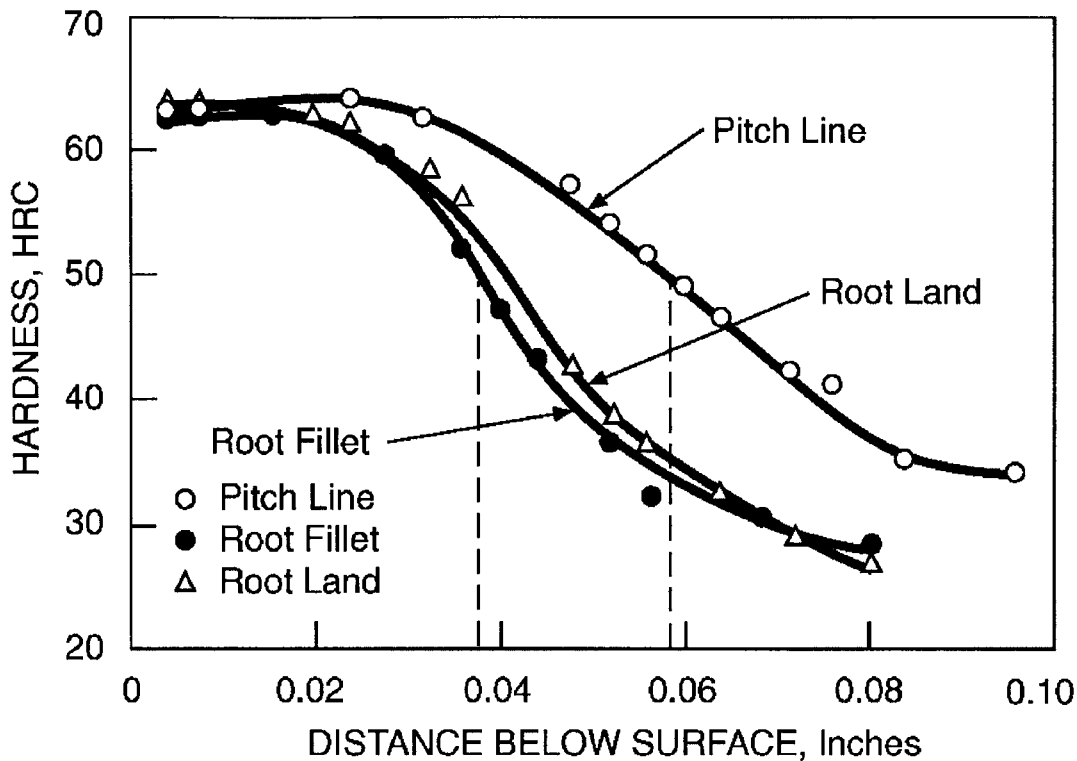
**Fig. 5.7** Step-ground specimen for hardness-traverse method of measuring depth of medium and heavy cases. Arrows indicate location of hardness-indenter impression.

is considered a better approximation of effective case depth and is successfully used in various aerospace applications.

Now the question is, how much case is needed on a gear tooth to prevent case failure due to Hertzian contact stress that causes pitting? In general, high case depths adversely affect the quality of case and, hence, the gear life. So, the determination of proper case depth on a gear tooth is quite important and is based on its capacity to resist contact stress-induced pitting.

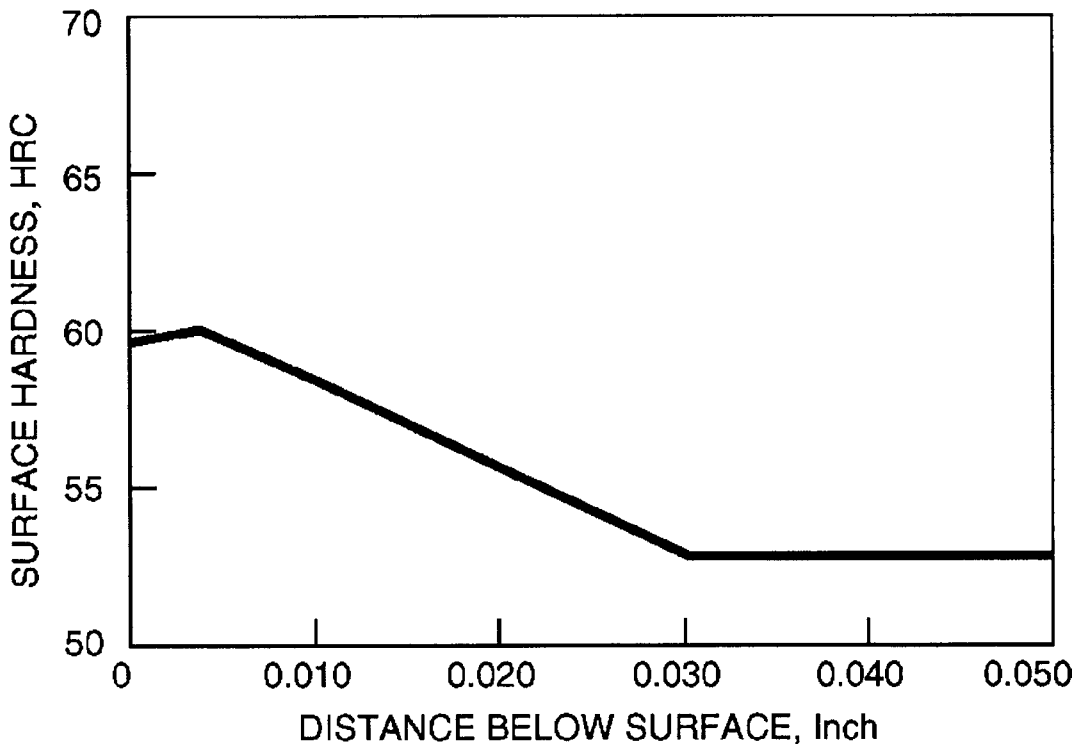
**Determination of Case Depth-Shear Stress Theory.** Of the several parameters used in optimizing a gear design, case depth, surface hardness, and core hardness of tooth are of significant importance. These three parameters are normally selected on the basis of applied load to a gear and its required life under the service conditions. Research carried out shows that a proper combination of case depth, surface hardness, and core hardness provides the maximum gear life. Analytically, these parameters are determined as outlined subsequently.

In transmitting torque, a gear tooth is subjected to at least two types of major stresses: contact and bending. These stresses cause tooth failure due to metal fatigue.



**Fig. 5.8** Variation of hardness with distance below the surface for a carburized and hardened gear made of 8620H steel

Gear tooth failure due to contact stress, commonly known as pitting, occurs when small pits initiated by fatigue cracks are formed on or below the tooth surface. These pits usually emanate at the highest point of single-tooth contact (HPSTC) for pinion and at the lowest point of single-tooth contact (LPSTC) for the mating gear (Fig. 5.10). The occurrence of pits is also found to be influenced by other factors such as surface quality (surface finish, microstructure of case, etc.), surface hardness, lubricating conditions, and operating temperature. Empirically, to resist crack-initiated pit formation, a gear designer considers maximum contact stress to act along the axis of load at HPSTC or LPSTC. There are two current theories that prevail to explain formation of cracks on any of these axes. The most widely held theory for well-lubricated gears is based on shear stress induced cracks below the surface due to contact load. The second one is based on cracks initiated at the surface, which happens only when the coefficient of friction goes below 0.1. According to shear stress induced pit formation below the surface, the maximum shear stress occurs on the axis of maximum contact load at HPSTC for pinion and LPSTC for gear. Because of the presence of sliding at these points, it is not known at what angle to the load axis the plane of maximum shear stress lies. That the maximum shear stress occurs at  $45^\circ$  to the load axis below the surface is true for pure rolling condition. In gear mesh, pure rolling exists only at

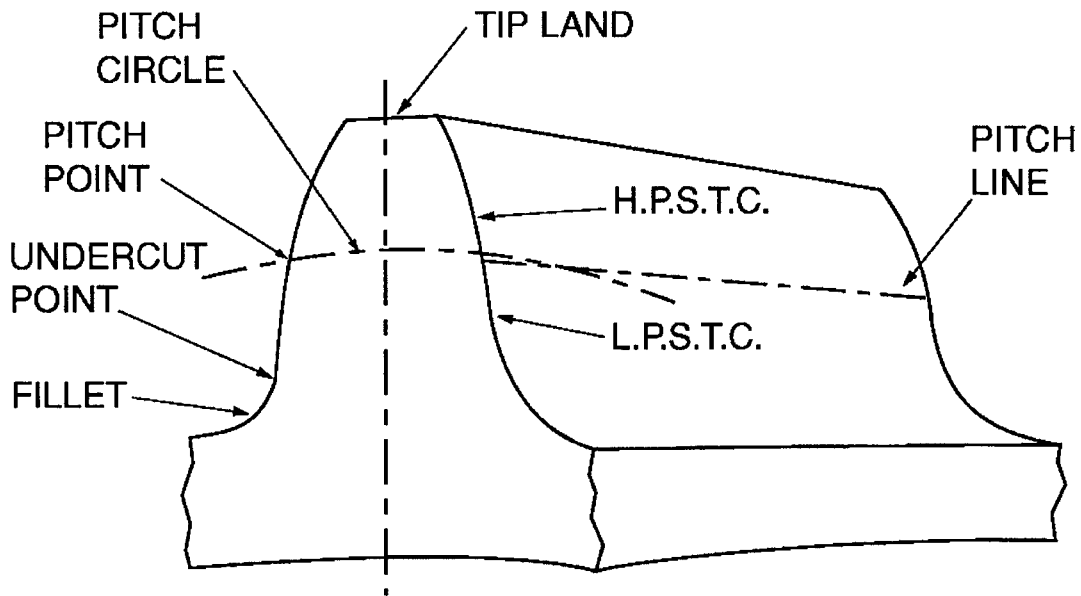


**Fig. 5.9** Variation of hardness versus case depth in gears made of HP 9-4-30 steel



the pitch point. Above and below this point there is sliding. This alters the location and magnitude of shear stress and presents difficulty in determining the point of maximum shear stress. To overcome this difficulty, the peak value of shear stress is assumed to occur below the pitch point and is quite valid for a well-lubricated gear mesh (coefficient of friction,  $\mu \approx 0.1$ , Fig. 5.11). Under these conditions, the value of the maximum shear stress is found to be  $0.140 (0.304) P_0$  at a depth of  $20 (0.786)b$ , where  $P_0$  is the maximum contact load in kg (lb) and  $b$  is the half width in mm (in.) of contact ellipse between two meshing teeth (Fig. 5.12). The shear stress so induced causes plastic flow in the outer core while the harder case still behaves elastically. This makes a Poisson's ratio for the core to deviate from 0.3 to approximately 0.5 while that of the case remains near 0.3. Thus, the core will tend to contract more than the case, inducing transverse stress, which, in turn, produces triaxial tensile stress in the core. This in combination with the discontinuity in the compressive hoop stress at the case-core interface causes cracks to form.

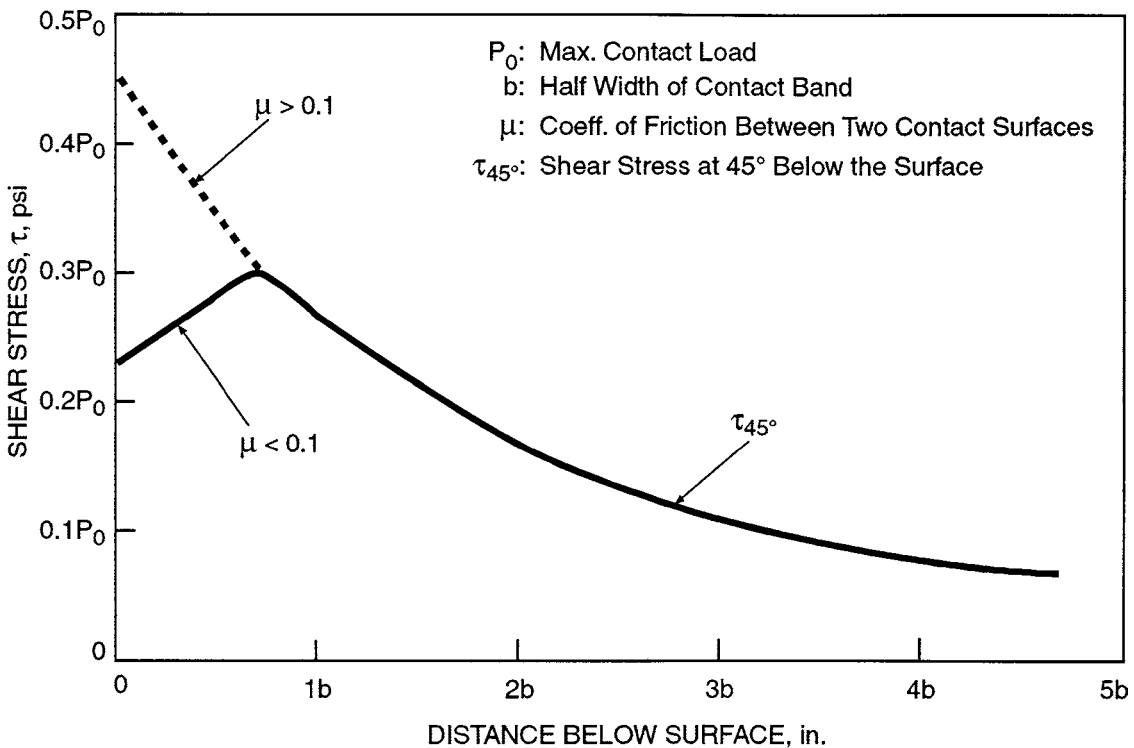
Cracks formed by this mechanism at the case-core boundary are resisted by the toughness of core for propagation in the direction of the core. Facing such resistance, cracks then follow the path of maximum tensile stress that exists in the case and finally find their way out to the surface, resulting in a pitlike formation. Progressive pitting of this nature destroys the tooth profile, and the gears run rough with increased vibration levels until the teeth break off.



**Fig. 5.10** Gear tooth profile

To prevent destructive pitting of this nature, a gear design engineer needs to make sure that the maximum shear stress lies well within the case so as not to cause any plastic flow of material in the case-core boundary. This does not mean that one should specify case depth more than what is needed. Deep cases have some adverse effects on the properties of case such as excessive retained austenite, free carbides, internal oxidation, and so on. Many of these may be responsible for modifying the residual stress distribution in the quenched case in a manner not quite beneficial to the gear life.

The theory as explained is quite useful and seems to satisfy the design requirements of gears made from most low- and high-alloy steels. But it fails to explain crack formation in gears made of some high-alloy steels with high core hardness. In these gears, pits are formed at or just below the tooth surface due to some induced tensile stresses in the case, and the gears do not seem to require high case depth as in low core hardness steels. This is possible only if the coefficient of friction becomes less than 0.1. The magnitude of maximum shear stress under this condition is approximately  $0.25 P_0$ . Hence, case depth requirement may be reduced in comparison to shear stress induced pit below the surface theory. Experimental investigations so far carried out show this theory to be true for gears made of materials such as HP 9-4-30 with core hardness over 50



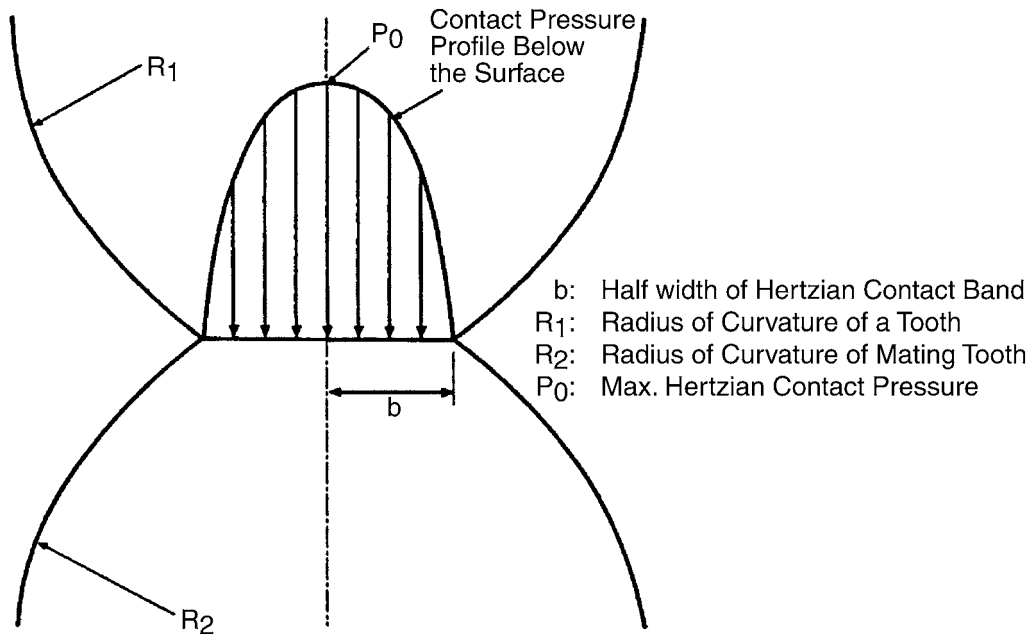
**Fig. 5.11** Shear stress distribution along the load axis of two parallel cylinders under contact pressure

HRC. Further tests are needed for its wider acceptance with high core hardness steels. Until then, the shear stress below the surface theory will be used to determine case depth at pitch diameter of carburized gears. Now, the question is how much case depth is needed to resist bending fatigue failure of a tooth.

Gear tooth failure due to cyclic bending stress occurs when the bending stress at the root fillet surface exceeds the allowable bending fatigue strength, which is dependent on the core hardness. Higher core hardness results in higher allowable bending fatigue strength. But there is an optimum range of core hardness for maximum bending fatigue life of gears. On the other hand, case depth at the root fillet does not seem to have any direct relationship with the bending fatigue life, although it has been found that case depth indirectly influences bending fatigue characteristics through altering the magnitude of surface residual stress. In general, the case at the root fillet develops high compressive surface residual stress that is considered beneficial for improved bending fatigue life.

**Total Case Depth.** The shear stress theory, as explained, is used to determine the point of maximum shear stress below the surface at the pitch line (Fig. 5.13). Knowing this point, the total case depth ( $\delta_c$ ) may be calculated for gears with different core hardness from the following relationship:

$$\delta_c = k\delta_t \dots \quad (\text{Eq 6})$$

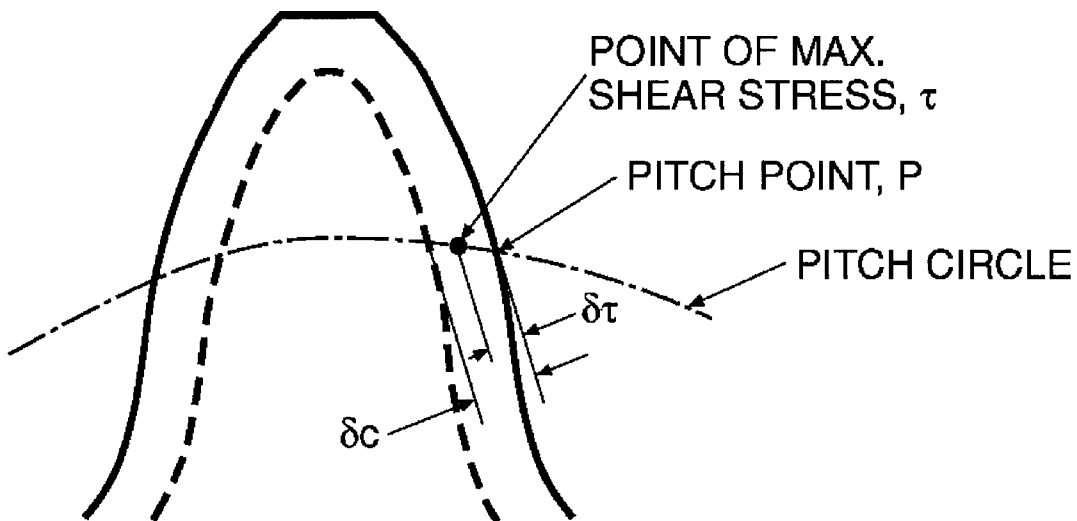


**Fig. 5.12** Contact stress profile between two meshing gear teeth

where  $\delta\tau$  is the depth at the point of maximum shear stress below the surface, and  $k$  is a constant that depends on core hardness of gear. For a safe design, its value may be taken as: 2 for core hardness up to 48 HRC, and 1.2 for core hardness above 48 HRC. Total case depth obtained with Eq 6 has been applied successfully to industrial, automotive, and aerospace gears.

In the author's experience, the total case depth obtained by considering  $k = 1.2$  works well for some high-alloy steel gears such as HP 9-4-30 with core hardness above 48 HRC. The case depth thus obtained does not deteriorate pitting or bending fatigue life or induce any failure due to case crushing. Furthermore, this seems to improve bending fatigue life, particularly when carburizing is done in vacuum furnaces. This is partly due to uniform case depth along the tooth profile including root fillet that is achieved with vacuum furnace carburizing. Carburizing in atmospheric furnaces cannot assure such consistency.

**Recommended Total Case Depth for Low-Alloy Steel Gears.** As discussed, the case depth required on a carburized tooth is primarily a function of its diametral pitch. The bigger the tooth, the deeper the case needed to carry the loads. Also, for each size of tooth there is an optimum case depth. Too much case makes the tooth brittle with a tendency for the tip of the tooth to shatter. Too thin a case, on the other hand, reduces tooth strength and resistance to pitting. Table 5.3 shows the general practice on case depth for different DP gear tooth based on maximum shear stress theory.



**Fig. 5.13** Estimation of total case depth

**Table 5.3 Recommended case depths at pitch line**

Diametral pitch (DP)	Case depth, mm (in.)
20	0.25–0.46 (0.010–0.018)
16	0.30–0.58 (0.012–0.023)
10	0.50–0.90 (0.020–0.035)
8	0.64–1.02 (0.025–0.040)
6	0.76–1.27 (0.030–0.050)
4	1.02–1.52 (0.040–0.060)
2	1.78–2.54 (0.070–0.100)
1	2.29–3.30 (0.090–0.130)

**Table 5.4 Recommended case and core hardnesses at pitch line of low-alloy steel gears**

Application	Surface hardness, HRC	Core hardness, HRC
General-purpose industrial gearing	55 min	28–32
High-capacity industrial gearing	58 min	32–38
Aircraft gearing	60 min	38–48

Carburizing of gears with acceptable case microstructure below 1 DP is extremely difficult because of tooth size. This is the reason, carburized and hardened gears below 1 DP are rarely used in industrial applications. If surface hardening is needed for such gears, an alternate hardening process such as induction hardening is recommended.

For extremely critical gears, it is advisable to hold case depth toward the maximum as shown in Table 5.3 and the minimum limit raised. For example, case depth on a critical 10 DP gear might be held to 0.635 to 0.90 mm (0.025–0.035 in.) case depth instead of 0.508 to 0.90 mm (0.020–0.035 in.). The case depth so specified is the total case depth as noted in an etched specimen. The effective case ( $h_{ec}$ ) for surface durability is taken to be about 75% of the total case or may be estimated by the following equation:

$$h_{ec} = \frac{S_c \cdot d \cdot \sin \phi_t}{7.0 \times 10^6 \cdot \cos \Psi_b} \left( \frac{m_G}{m_G + 1} \right) \text{ in.} \quad (\text{Eq 7a})$$

where  $S_c$  is the maximum contact stress, psi, in the region of  $10^6$  to  $10^7$  cycles;  $d$  is the pinion pitch diameter (in.);  $\phi_t$  is the pressure angle;  $\Psi_b$  is the base helix angle; and  $m_G$  is the tooth ratio.

In metric units:

$$h_{ec} = \frac{S_c \cdot d_m \cdot \sin \phi_t}{48,250 \cos \Psi_b} \left( \frac{m_G}{m_G + 1} \right) \text{ mm} \quad (\text{Eq 7b})$$

where  $S_c$  is the maximum contact stress, N/mm<sup>2</sup>;  $d_m$  is the pinion diameter, mm.

Recommended case and core hardnesses at pitch line for different applications are given in Table 5.4.

**Case Depth at Tooth Tips.** Under normal conditions, gear tooth tips do not experience any load. In case of misaligned gears, the tips may be subjected to high contact load due to which they may fail, particularly if the tips are through hardened during carburizing. To avoid such failures, case depth in the region of tooth tips,  $h_{em}$ , should be between 0.3 and 0.4/DP in inches or 0.3 and  $0.4 \times$  module mm.

Recommended case depths at tooth tips are given in Table 5.5.

**Grain Size and Case Depth.** Besides time and temperature, case depth also depends to a certain extent on grain size of steel. Coarse-grain steels (ASTM-4) develop deeper case, whereas fine-grain steels (ASTM 10-12) cause shallow case. Grain size between ASTM 5 and 7 is recommended for proper case depth.

The grain size usually is reported as a number that is calculated from the relation:

$$n = 2^{N-1} \quad (\text{Eq 8})$$

where  $n$  is the number of grains per square inch at a magnification of 100 $\times$ , and  $N$  is the grain size number commonly called the ASTM grain size.

Table 5.6 shows ASTM grain size and grains per square inch.

**Table 5.5 Recommended case depth at tooth tip**

Diametral pitch (DP)	Maximum case depth, mm (in.)
20	0.71 (0.028)
16	0.86 (0.034)
12	1.17 (0.046)
10	1.40 (0.055)
8	1.75 (0.069)
6	2.34 (0.092)
4	3.18 (0.125)
2	3.56 (0.140)

**Table 5.6 ASTM grain size**

ASTM No.	Mean No. of grains/in. <sup>2</sup>	ASTM No.	Mean No. of grains/in. <sup>2</sup>
1	1	7	64
2	2	8	128
3	4	9	256
4	8	10	512
5	16	11	1024
6	32	12	2048

## Core Hardness of Gear Teeth

Core hardness of teeth, as already discussed, is an important parameter that determines the strength of a gear tooth. Currently, it is a common practice in the gear industry to accept hardness at the center of a tooth on form diameter as the core hardness (Fig. 5.14). This consideration has some merit. First, it allows a conservative estimate of allowable bending fatigue strength of a tooth because the hardness at the point of maximum bending stress that occurs near the root surface is higher than at the center of the tooth. Hence, the actual bending strength of a tooth is always higher than what is considered to establish its bending fatigue life. Second, it identifies a definite spot in a tooth to measure hardness.

The major drawback of this practice is hardness at this location is always low for low-hardenability steels. Hence, the allowable strengths are low. This makes the gears made of such steels large, and eventually, the gearbox becomes large. In reality, the locations of maximum stresses that cause failures are not at the center of the tooth. Recent investigations show maximum tensile stress due to bending of a tooth that causes failure occurs just below the case at root, and also the stress that causes case crushing is located in the case-core interface area on the pitch diameter. Hardness in these areas is of importance because this is where failures

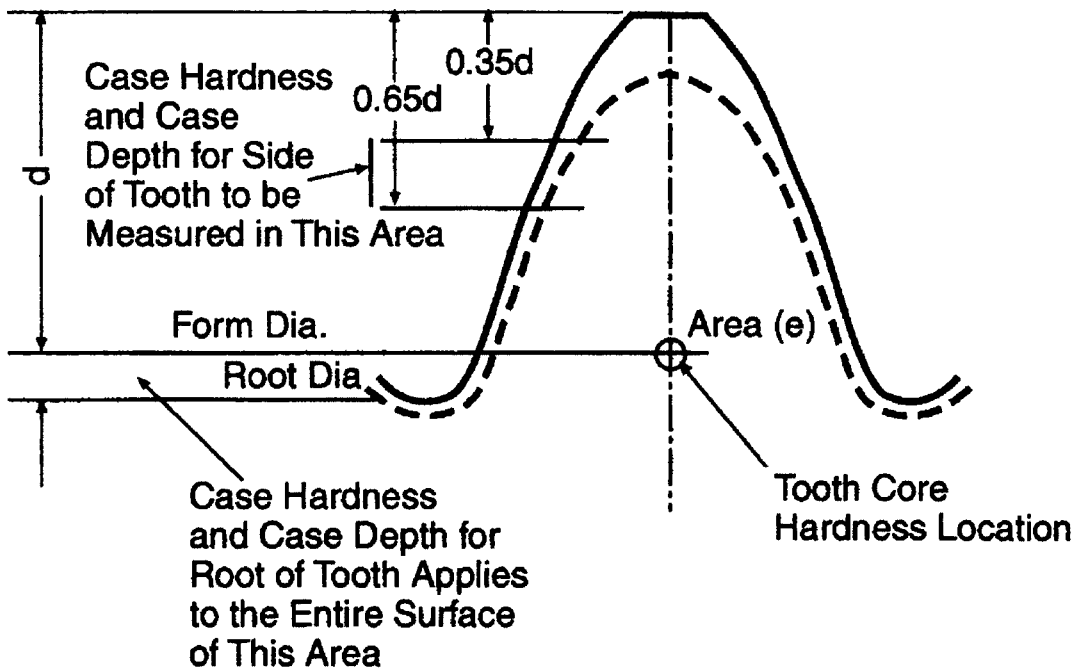


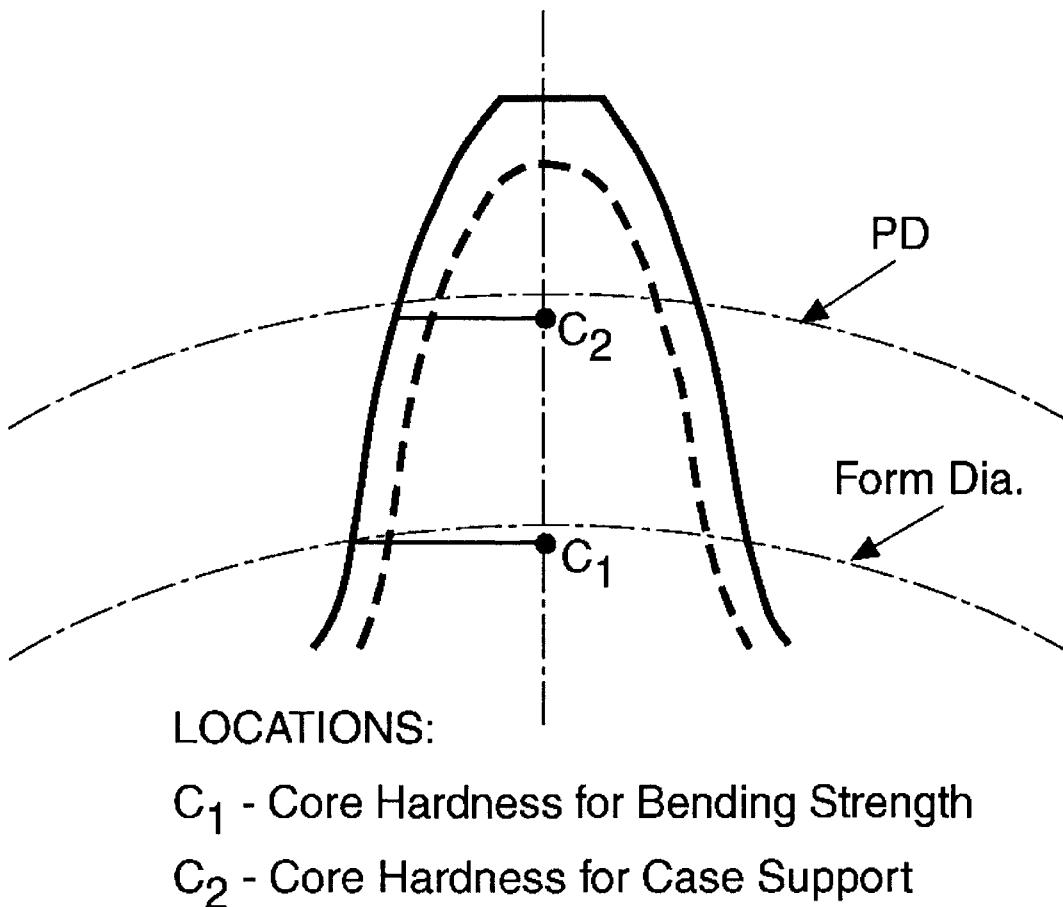
Fig. 5.14 Measurement locations of case and core hardnesses

originate, and they are substantially higher than at the center of tooth. Hence, it is logical to determine bending or case crushing failures on the basis of these strengths. Such considerations would be beneficial in optimizing gear designs that are bending-strength limited.

The main problem with the new approach lies in precisely identifying the locations for proper core hardness measurements. To avoid complexity in preparing a sample and subsequent discrepancy in measurements, the following locations are considered realistic as illustrated in Fig. 5.15:

- $C_1$  for bending strength: Between root and center of tooth
- $C_2$  for case crush support strength: Between pitch point and center of tooth

**Core Hardness versus Maximum Bending Strength.** Metallurgically, for a carburized and hardened gear tooth, higher core hardness



**Fig. 5.15** Measurement locations of importance for core hardnesses

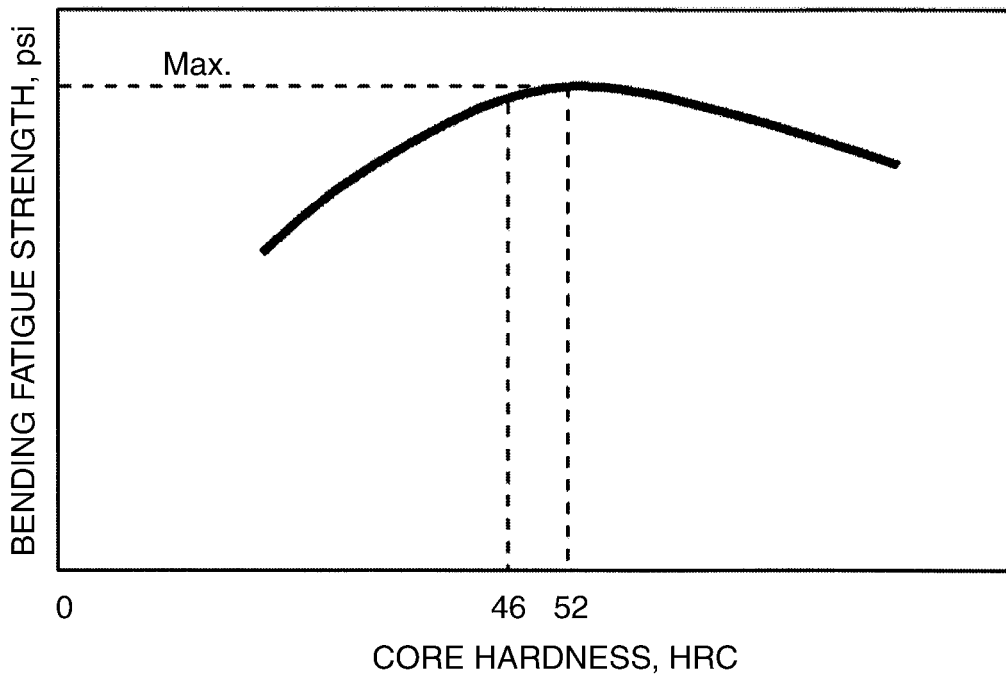


results in higher bending fatigue strength. But unfortunately, this relationship is not fully true for gears. Research shows maximum bending fatigue strength of a gear tooth for low- and high-alloy steels is achieved with core hardness in the range of 34 to 46 HRC. It is easy to understand the reason for lower bending fatigue strength for core hardness below this range. Why bending fatigue strength for such alloys does not increase above this range is difficult to explain. For very high-alloy (above 9%) steels such as HP 9-4-30, maximum bending strength is achieved with core hardness between 46 and 50 HRC. It is believed at core hardness above 52 HRC, an unsatisfactory tensile residual stress is occasionally observed. Figure 5.16 illustrates the relationship of core hardness with bending fatigue strength of carburized and hardened gears.

Table 5.7 shows achievable core hardness range (HB) versus DP of tooth for some commonly used carburizing grade gear materials.

**Surface Oxidation Effect.** Oxidation at the surface should be avoided during carburizing. The most undesirable effect of surface oxidation is a loss of hardenability because  $O_2$  reacts preferentially with the alloying elements. It is less of a problem for steels with high-alloy content.

**Grain Size and Core Hardness.** Sometimes, full core hardness is not achieved in gears made from a “heat” of very fine grain steel (ASTM



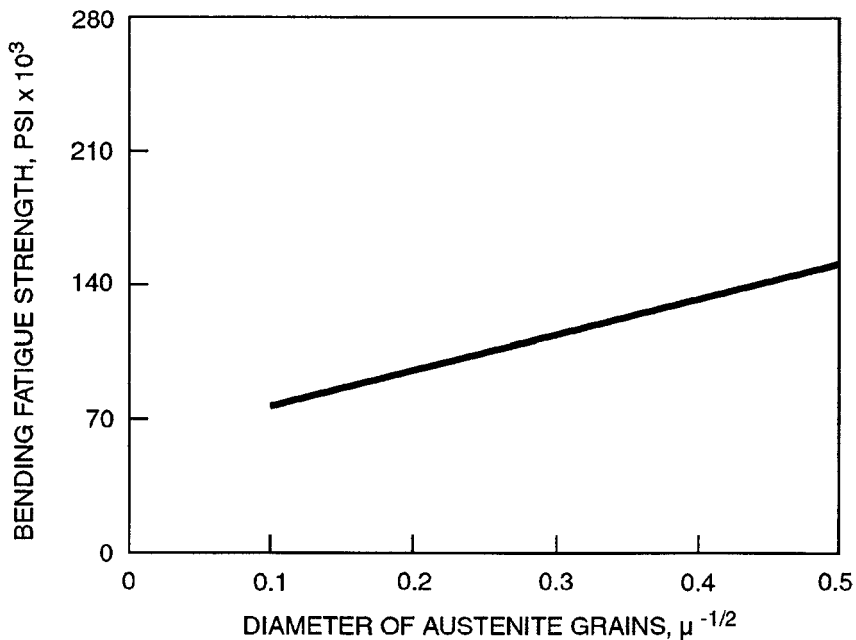
**Fig. 5.16** Core hardness vs. bending fatigue strength of gear tooth

10–12) instead of normally used ASTM 5 to 7. It is not unusual to see approximately one point HRC hardness gain or loss accompanied with each grain size change in gear tooth size from 3 to 6 DP. In general, core hardness drops as grain size becomes finer and increases when it coarsens. Similarly, bending fatigue strength increases with increase of austenitic grain size as illustrated in Fig. 5.17. Pitting fatigue strength, on the other

**Table 5.7 Core hardness of tooth for some gear materials**

Diametral pitch (DP)	Core hardness, HB			
	AISI 4620	AISI 8620	AISI 4320	AISI 9310
0.75	180–230	180–250	215–270	245–340
1	180–245	180–260	225–300	260–360
1.25	180–260	230–290	240–325	280–370
1.5	200–280	230–310	255–343	285–380
1.75	200–280	235–320	260–350	290–380
2	225–310	240–335	270–370	300–380
2.5	235–340	250–360	280–390	310–390
3	235–340	260–390	300–400	310–390
3.5	235–340	270–395	315–410	315–390
4	255–375	290–400	315–410	315–390
5	290–395	320–420	335–420	315–390
6	310–405	320–420	340–430	315–390
7	310–405	335–430	340–430	315–390
8	310–405	335–430	340–430	315–390
10	350–425	370–440	370–440	315–390

Core hardness ranges are based on min and max hardenability curves for H grades and quench temperatures between 97 and 111 °C (175 to 200 °F).



**Fig. 5.17** Austenitic grain size and bending fatigue strength of a typical gear steel

hand, increases with finer grain size. It is to be noted that the temperature to which a steel is heated has a marked influence upon the austenitic grain size. It is necessary, therefore, when determining the austenitic grain size of carburized steels, to make the determination under conditions that are similar to the heat treating procedure.

**Effect of Carburizing Processes on Surface Carbon.** Surface hardness and hardness below the surface are dependent on carbon gradient. For higher surface hardness without a large carbide network, 0.80% carbon is preferred on the surface. For low carbon potential (below 0.70%), some decarburization may take place at the surface of steel during carburizing by any of the processes such as endothermic, vacuum, fluidized bed, and vacuum pulsation. Decarburization results in lower surface hardness after quenching. This is why it is important to maintain proper carbon potential during carburizing. Also, the penetration of carbon into the surface depends on the carbon gradient, which is found to vary with the carburizing process selected. Figure 5.18 illustrates various carbon gradients for gears made of HP 9-4-30 with different carburizing processes. It shows that carburizing in a vacuum pulsating-type furnace offers the highest carbon on the surface for the same carbon potential. Figures 5.19 and 5.20 illustrate typical carbon profiles for AISI 9310 and 8620 steels for different carbon potentials in an endothermic carburizing furnace.

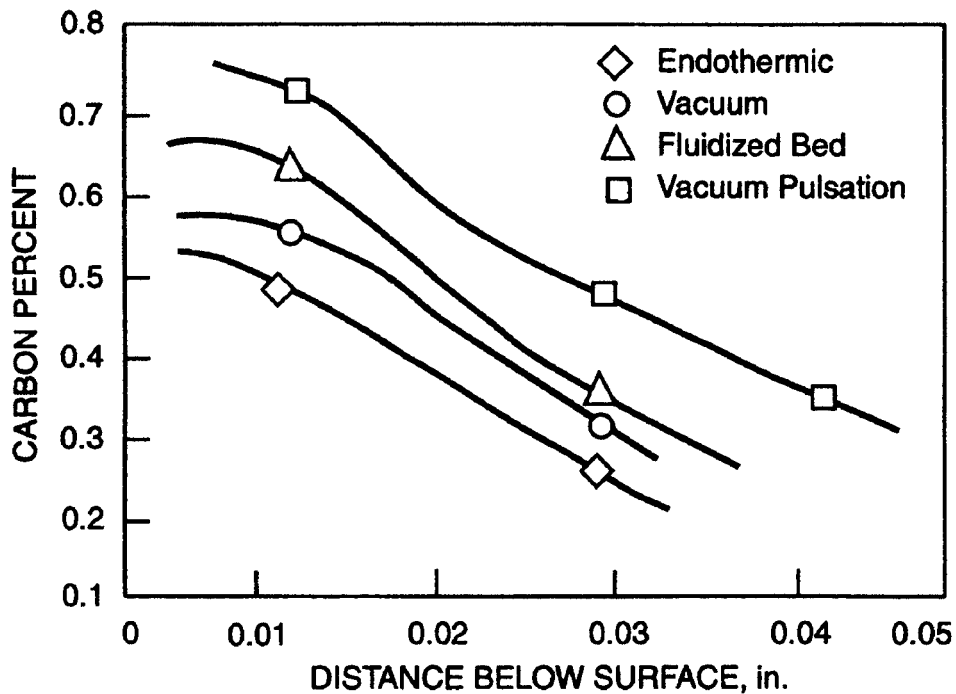
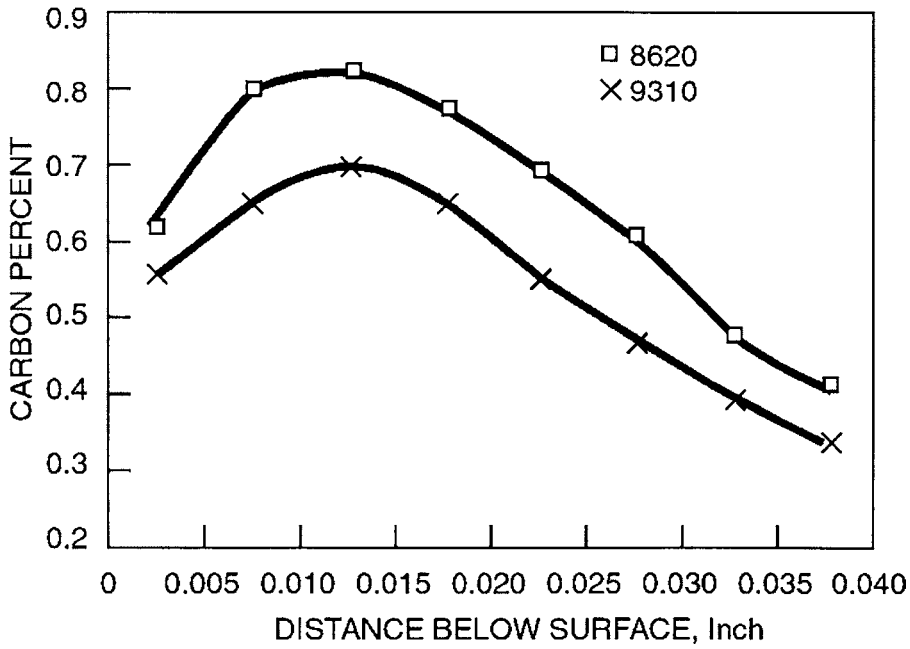
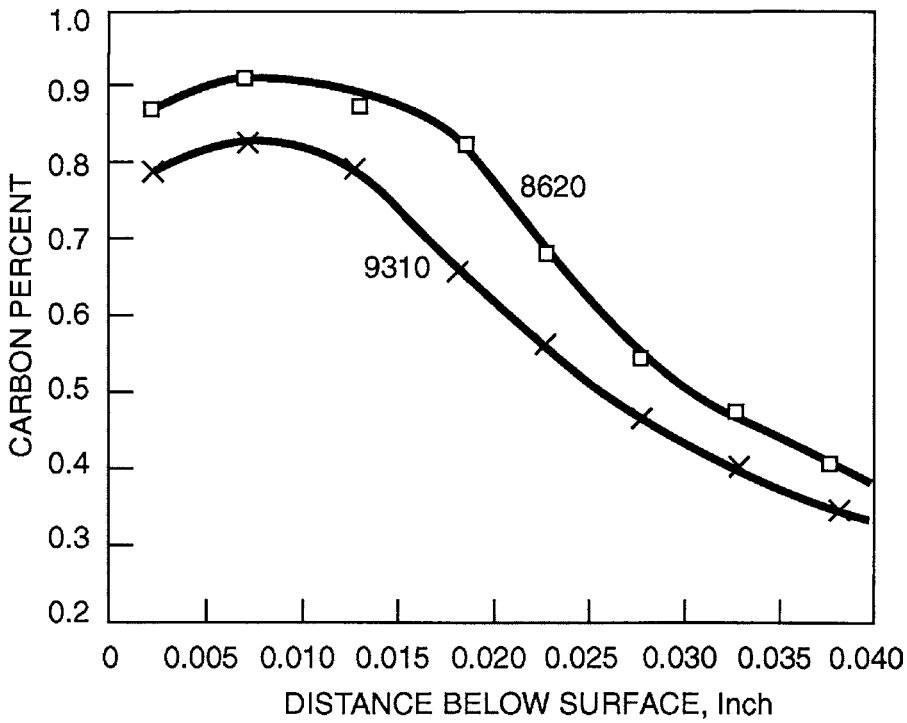


Fig. 5.18 Carbon gradients by different carburizing processes. Material: HP9-4-30



**Fig. 5.19** Carbon profiles for two different AISI steels (carburized with carbon potential of 0.7%)



**Fig. 5.20** Carbon profiles for the same two steels shown in Fig. 5.19 (carburized with carbon potential of 1.0%)

## Microstructure of Carburized Cases

---

The microstructure of a carburized gear tooth changes from the surface to the core. Depending on carbon content and post carburizing heat treatment, the microstructure at the surface will be pearlitic or martensitic, with or without grain-boundary carbides. Toward the interior, there is a gradual transition in microstructure to transformation products that are characteristics of lower carbon contents until the core is reached. In some steels, there is only a transition from high-carbon martensite to low-carbon martensite, but in other steels, there is a transition from pearlite with proeutectoid cementite through eutectoid pearlite to a predominantly ferritic structure. Such a gradation in microstructure is useful to measure case depth by microscopic examination.

In planning carburizing of a gear, it is thus necessary to consider both the carburizing cycle and the post carburizing heat treatment. The proper control of heat treatment develops the required properties in the core and at the same time, develops the required tooth surface hardness and hardness gradient in the case. Case properties depend strongly on carbon content and carbon gradient. It is only through adjustment of carbon content and carbon gradient that the heat treatment can be made to develop good case properties.

The microstructures of case and core also are influenced by the heat treatment after carburizing. Because of the generally low carbon content in the core, its structure may consist of low-carbon martensite to mostly ferrite. On the other hand, the case structure, because of higher carbon content, may contain martensite, bainite, or pearlite, depending on the rate of cooling from the austenitizing temperature. Some proeutectoid ferrite may appear near the case-core interface, especially if the cooling rate is slow. In some alloy steels, retained austenite may appear near the surface, particularly if the surface carbon content and the austenitizing temperature are high or the cooling rate is too fast. Steels containing nickel are especially susceptible to such austenite retention. Microstructure requirements of case and core generally vary with the class of gears. Table 5.8 shows recommended microstructures for different classes of gears. Metallographic standards for case and core structures of these gears are illustrated in Fig. 5.21 to 5.23.

## Some Carburizing Problems

---

During carburizing, gear tooth tips experience higher carbon absorption than at the roots. The reason for this is the convergence of carburizing gas flow at the tips, whereas divergence exists at the root area as illustrated in Fig. 5.24. As a result, the case thickness does not run parallel to the tooth

profile. The thickness is deeper at the tip and shallower at the root. Consequently, this difference results in the slope variation of hardness versus case depth relationship taken at different points on a gear tooth as depicted in Fig. 5.25. The difference in case depth becomes more critical as the gear tooth geometry also changes. For example, with an increase in pressure angle, the case thickness at the tip increases significantly, making it almost through hardened. Figure 5.26 shows this condition. Such tooth tips are very brittle and subject to chipping in case of any misalignment of gears.

**Copper Plating of Gear to Control Case Depth at Tooth Tip.** To overcome the problem of high case depth at tooth tips, very frequently gear blanks are plated with copper before cutting the teeth. After the teeth are cut, plating is still left on the tooth land, which acts as a buffer during carburizing and reduces case depth at and near the tips of the gear teeth. Results obtained so far show that copper plating helps the reduction of case near the tips of coarse pitch (up to 10 DP) and small pressure angle (up to  $20^\circ$ ) gear teeth where an appreciable top land exists. In finer-pitch (20 DP and higher) and higher-pressure angle gears (above  $20^\circ$ ), the tooth land is relatively small, and copper plating offers only limited case depth control at the tips. On the basis of recent experimental work, the

**Table 5.8 Hardness and microstructure requirements in case and core for different classes of carburized and hardened gears**

Gear class(a)	Process	Material	Hardness		Area of part	Microstructure
			Case surface (Knoop 500 g)	Core HRC		Requirement
A	Carburize and harden	Carburizing grade	720 min on tooth surfaces 710 min at root fillet areas	34–44	Case	High-carbon refined tempered martensite. Retained austenite 10% max. Continuous carbide network or cracks are not acceptable. Scattered carbides are acceptable provided the max carbide particle size does not exceed 0.005 mm (0.0002 in.) in any direction. Transformation products such as bainite, pearlite, proeutectoid ferrite, or cementite not permitted in excess of the amount. No white martensite (untempered) permitted.
					Core	Low carbon (tempered) martensite. No blocky ferrite, pearlite, or bainite. Ferrite patches not to exceed 1.6 mm ( $\frac{1}{16}$ in.) in width or length as measured at 250 $\times$ magnification. Excessive banding not permitted.
B	Carburize and harden	Carburizing grade	690 min (all areas)	30–44	Case	High-carbon tempered martensite. Retained austenite 20% max. No continuous carbide network is acceptable. Scattered carbides are acceptable provided the maximum carbide particle size does not exceed 0.010 mm (0.0004 in.) in any direction. Surface oxidation not to exceed 0.013 mm (0.0005 in.). Transformation products not permitted in excess of the amount shown. No white martensite permitted.
					Core	Essentially low-carbon martensite with some transformation products permissible. Ferrite patches up to 3.18 mm ( $\frac{1}{8}$ in.) wide and length permissible as measured at 250 $\times$ . Excessive banding not permitted.
C	Carburize and harden	Carburizing grade	630 min (All areas)	28–45	Case and core	Defects such as laps and cracks are not permitted. Retained austenite, 30% max. Case depth shall meet drawing requirements. Excessive inclusions that may affect the function of the part shall be cause for rejection.

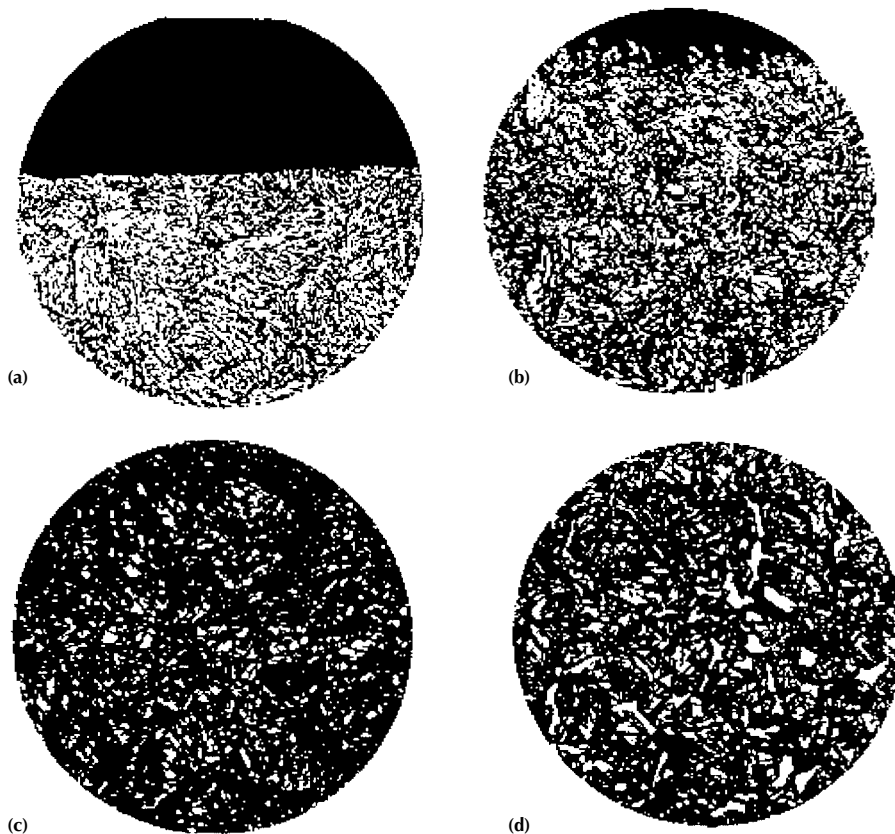
(a) A, critical applications where a gear failure may result in loss of life; B, not as critical as A but still requires high reliability; C, industrial application

following recommendations (Table 5.9) are put forward with regard to copper plating of gears before carburizing.

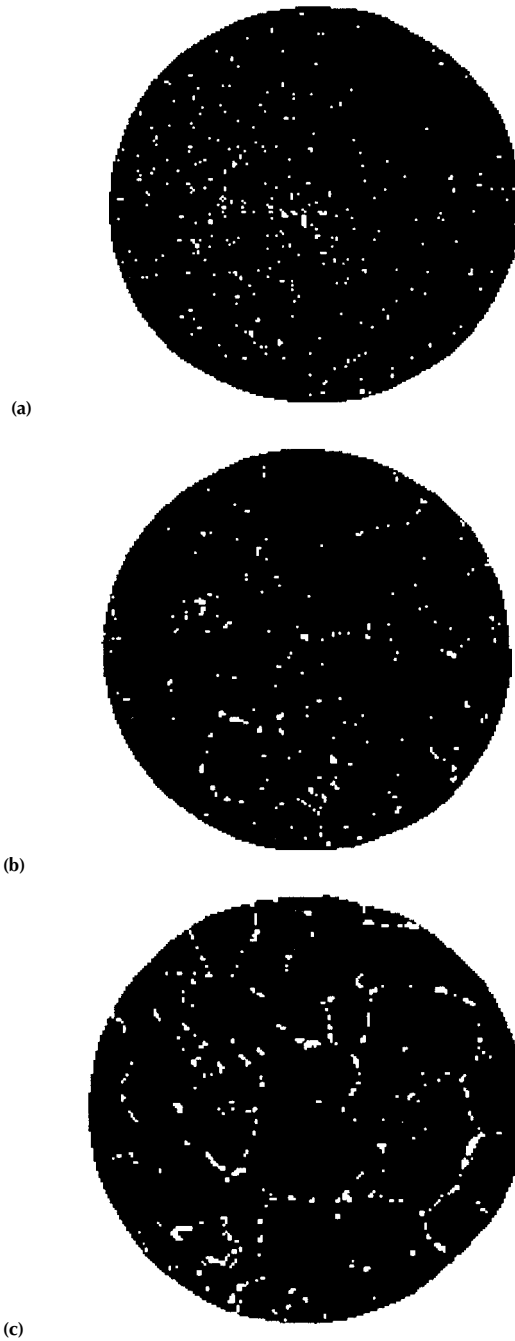
In industries where in-process inspection is critical, a note on the gear drawing is helpful (e.g., “peeling of plating on the edges of teeth resulting from gear cutting should not be the cause of rejection of plated gears”). Also, striping of plating after carburizing is not necessary provided a small amount of peeled copper plating is acceptable in the gearbox lubricating oil system.

**Tip and Edge Radii.** For good heat treatment and performance of gears, tooth tips and edges are to be rounded as suggested in Table 5.10.

**Retained Austenite and Its Effect on Gear Performance.** After carburizing and hardening, it is possible that some retained austenite may exist near the surface of the gear teeth. Steels containing nickel are



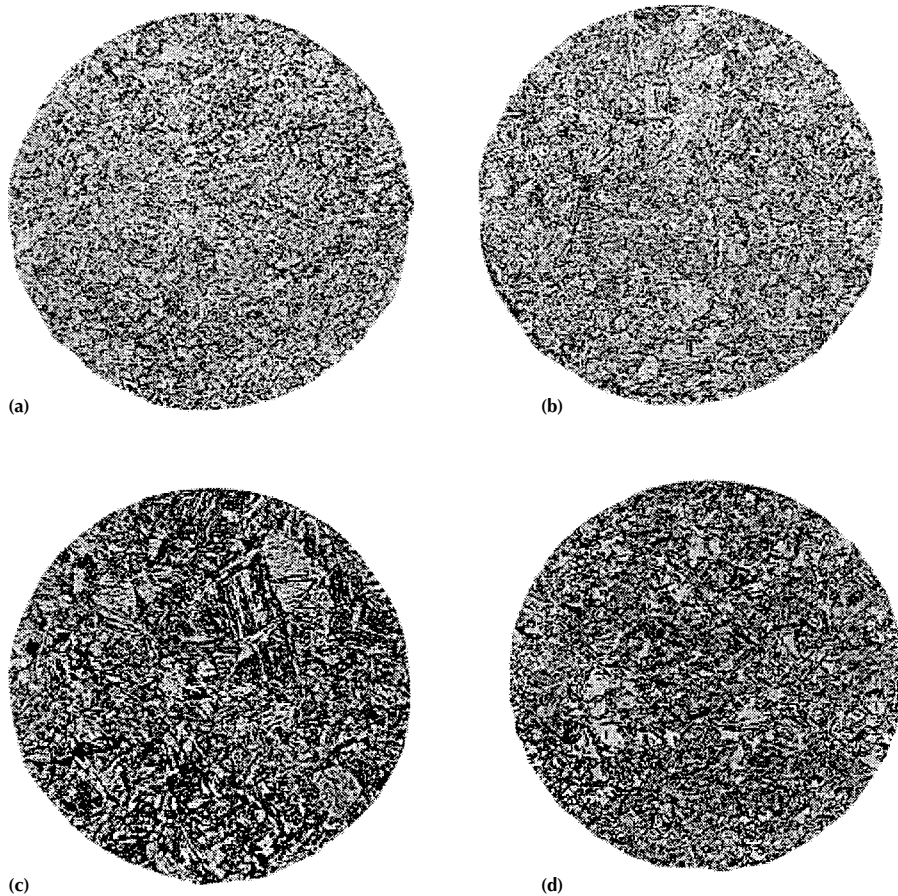
**Fig. 5.21** Metallographic standard for carburized, hardened, and tempered cases in grades A, B, and C gears. (a) Desired high carbon, carburized, hardened, and tempered martensitic case. No retained austenite. No surface oxidation. Acceptable for grade A. (b) Case structure 10% retained austenite and small amounts of transformation products. Maximum austenite permissible for grade A. (c) Case structure with 20% retained austenite and some transformation products. Maximum permissible for grade B. (d) Case structure with over 30% retained austenite and a considerable amount of transformation products. Continuous grain boundary carbides, massive carbides. Not acceptable for grade A or B



**Fig. 5.22** Metallographic standard for case carbides in carburized, hardened, and tempered cases. (a) Desired case carbide distribution for grades A and B gears; 4% nital etch, dark field illumination. (b) Scattered carbides in grain boundaries, maximum acceptable for grade A. 4% nital etch, dark field illumination. (c) Semicontinuous grain boundary carbides. Not acceptable for grade A; maximum acceptable for grade B. 4% nital etch, dark field illumination



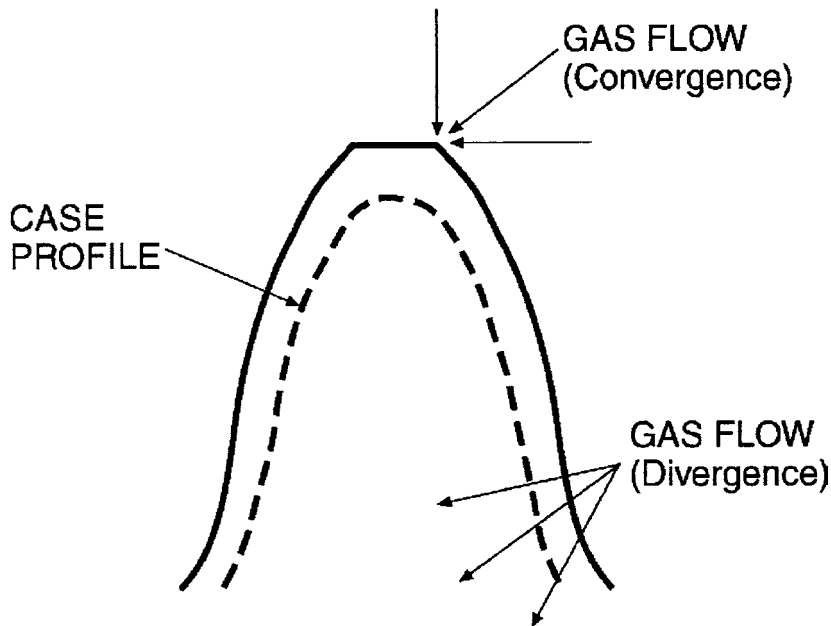
especially susceptible to such austenite retention. The retained austenite is not generally considered harmful to gear life when present in the amount not exceeding 15 to 20% by volume. In fact, retained austenite present between 15 to 20% by volume seems to increase bending fatigue resistance of gear teeth (Fig. 5.27). On the other hand, retained austenite in the martensitic microstructure of case lowers the surface hardness, which is not at all desirable for contact fatigue life. Also, a high percentage of retained austenite (above 20% by volume) is found to be



**Fig. 5.23** Metallographic standards for carburized, hardened, and tempered core structure. (a) Desired low-carbon, tempered martensite, free from ferrite patches and with some transformation products. Acceptable for grade A. (b) Low-carbon, tempered martensite with maximum allowable transformation products. Acceptable for grade A. (c) Low-carbon, tempered martensite with maximum allowable transformation products. Acceptable for grade B. (d) Tempered martensite with block ferrite patches. Not acceptable for grades A and B

detrimental during the service life of gears where the volume accompanying austenite-martensite transformation causes dimensional change in gear tooth geometry. Furthermore, martensite formed in this manner is untempered and brittle and may accelerate crack formation in the case. Hence, it is essential to control the amount of retained austenite for maximum service life of gears. Recent research indicates that finely dispersed, retained austenite in the amount of up to 15% is not detrimental to the contact fatigue (pitting) life of gears. Retained austenite above 20% may cause “grind burn,” discussed at the end of this chapter, particularly if the gears are ground on wet gear grinding machines with vitrified aluminum oxide wheels.

A number of variables during carburizing affect retained austenite in gears. These variables include carbon potential, quench temperature, cooling rate, and so on. Holding the carbon potential between 0.7 and 0.85% and using quench oil temperature below 95 °C (200 °F) and fast cooling rate, the retained austenite can be significantly reduced. Another way of reducing the amount of retained austenite in the case microstructure is to cold treat the gears following quenching.



**Fig. 5.24** Gas flow over a gear tooth during carburizing

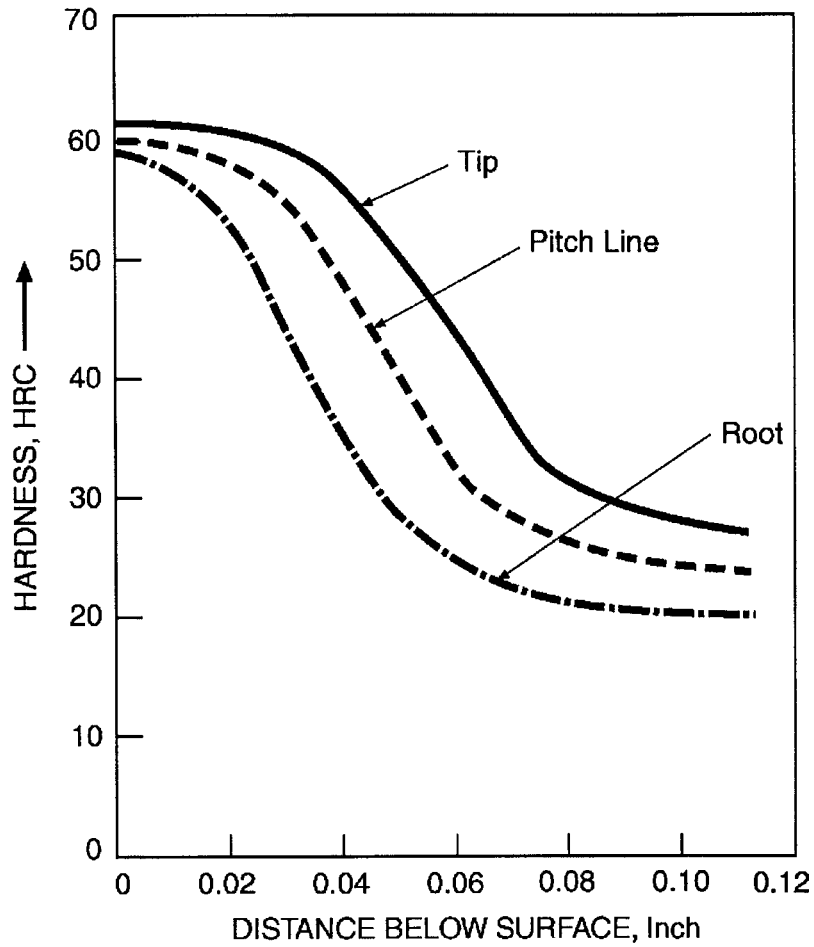


Fig. 5.25 Hardness profiles at different locations of a tooth

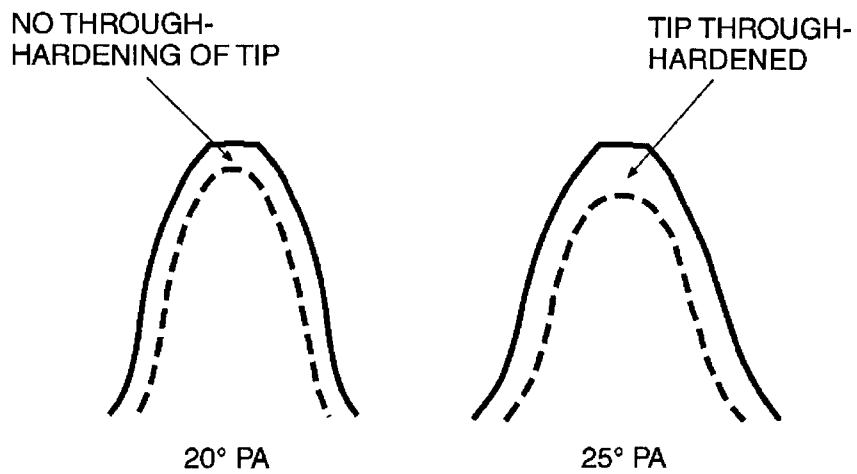


Fig. 5.26 Case depth profile vs. tooth pressure angle. Dashed line indicates case depth profile.

The specific amount of transformation achieved by a given subzero treatment is extremely difficult to predict. The degree of reluctance to transform at a given temperature is influenced by:

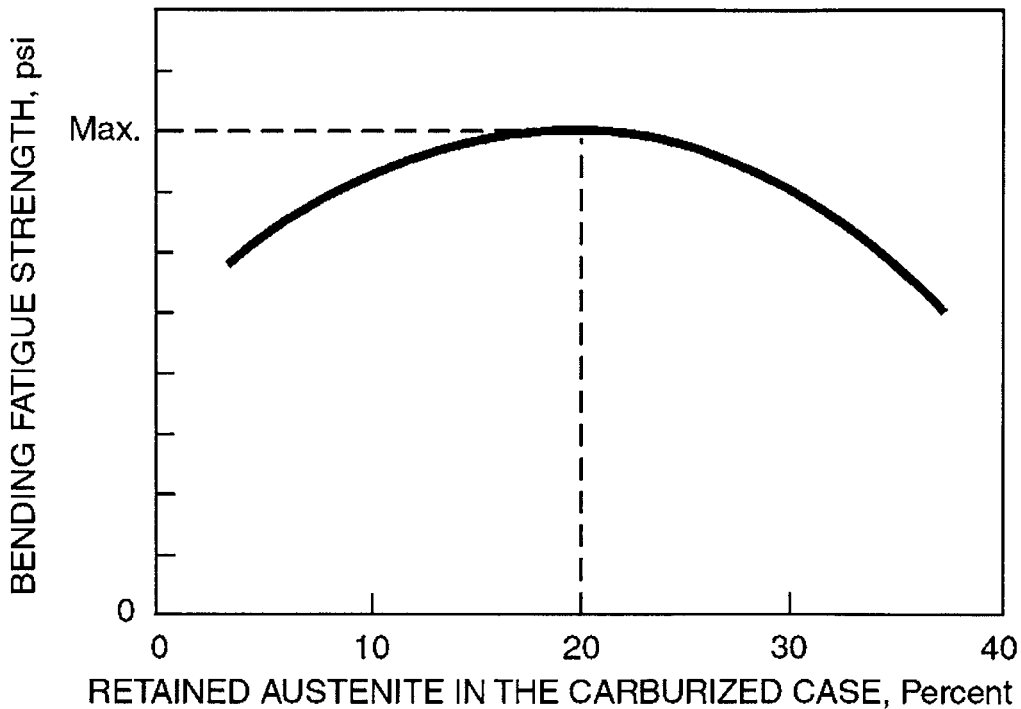
- The amount of retained austenite at the start of cold treatment
- The elapsed time between quenching and cold treatment

**Table 5.9 Copper plating of gears**

Diametral pitch (DP)	Pressure angle (PA)	Copper plating
15 and higher	20° and above	Plating not recommended
10–14	20° and above	May use plating on selective basis
10 and lower	20° and below	Use plating

**Table 5.10 Recommended tip and edge radii of teeth**

Diametral pitch (DP)	Tip and edge radii, mm (in.)
1–4	0.51–0.76 (0.020–0.030)
5–8	0.38–0.64 (0.015–0.025)
10–12	0.25–0.51 (0.010–0.020)
16–20	0.13–0.25 (0.005–0.010)



**Fig. 5.27** Influence of retained austenite on bending fatigue strength

- Any intermediate thermal treatment such as tempering
- The general level of residual compressive stress in the parts
- Any cold working of material such as straightening

Tempering of gears at 150 to 175 °C (300–350 °F) prior to cold treating is a common practice. It decreases the tendency to form subsurface microcracks. Also, tempering tends to stabilize retained austenite. After tempering, a slightly lower temperature is required to attain the same degree of transformation upon cold treating. Holding gears at room temperature for some time probably has a stronger stabilizing effect than tempering immediately after quenching. Because a volume increase accompanies such transformation, higher levels of compressive residual stress after quenching tend to retard transformation until lower temperatures are reached. Temperatures in the range of –75 to –100 °C (–100 to –150 °F) are routinely used in cold treating as already discussed.

To make sure the carburized case has the proper amount of retained austenite, it is necessary to have a proper measurement technique. Currently, there is no exact method to determine the percentage of retained austenite in a carburized case. Of the various methods available, metallographic examination and x-ray diffraction are frequently used. In metallographic examination, austenite is not attacked by nital, and therefore, it appears white when the nital-etched specimen is examined. Metallographic method, however, is not a reliable method of estimating the percentage of retained austenite. X-ray diffraction technique is considered to be more reliable. Even this method fails to positively identify the percentage when the retained austenite is below 10%.

## Heat Treat Distortion of Carburized and Hardened Gears

---

Distortion is always a problem in all heat treating processes, and it is most severe in carburizing and hardening. Thus, its reduction or elimination is a very important factor in the manufacture of high-quality gears. In gears, two types of distortion occur. One is a body distortion, which, for gears, is measured in terms of out of roundness, out of flatness, or run-out dimensions. The second is the distortion in gear tooth geometry. Body distortion also influences tooth geometry distortion a great deal. In general, distorted gears need a finishing operation after carburizing and hardening to improve their quality.

The mechanism of heat treat distortion is quite complex for any component and more so for gears. It is expected that the following brief discussion on this phenomenon will be helpful to manufacture high quality gears at an optimum cost.

## ***Mechanics of Heat Treat Distortion***

After carburizing, gears are quenched either in oil, water, or gas to increase tooth surface hardness. As the gear body cools during quenching, two types of internal stresses are induced: thermal and grain microstructure transformation.

**Thermal Stress.** Thermal stress is induced due to exterior surfaces of the gear cooling more rapidly and contracting than the inner ones, thus developing a temperature gradient. In alloy steels, the various alloying elements with different densities result in different specific volumes that cause additional thermal stresses. These internal stresses may cause extensive deformation as the gear cools down to room temperature. In general, the more drastic the quench is, the greater the thermal stress causing gear distortion.

**Transformation Stress.** During the carburizing process, as a gear is heated up to the first critical temperature, its volume increases. This volume then decreases as ferrite transforms into austenite. Once the austenitic transformation is complete, volume increases again with higher temperature. However, the coefficient of volumetric expansion is different for austenite than for ferrite. After the austenitic transformation, as the temperature is lowered, thermal contraction takes place until the temperature falls to quenching temperature. As the temperature drops during quenching, austenite is transformed to martensite and the volume increases again. This transformation goes on until the temperature drops to room temperature. Even at this temperature, all martensitic steels contain some austenite, the amount increasing with the amount of alloying elements dissolved during austenitization. The larger the quantity of retained austenite in the steel after hardening is, the smaller the increase in volume. Also, the volume of austenite increases with the amount of dissolved carbon.

Furthermore, all gear steels are basically anisotropic, which means the volume change occurring during the heat treat process will not be the same in the direction of rolling from which gear blanks are made as in the direction of right angles ( $90^\circ$ ) to it. The volume change in gears also is affected by the configuration and geometry of gear blanks (with or without web). All such volumetric changes induce additional stresses in a gear body that cause distortion.

## ***Material and Heat Treat Process Factors***

Besides thermal and transformation stresses, the following factors contribute significantly to the distortion of carburized and hardened gears.

**Quality of steel** plays an important role in the process of distortion. The better the quality of the steel is, the lower the distortion. For example, alloying segregation in any gear material may cause variations in hardness in a given cross section, which, in turn, initiates a differential response during machining operations. The result is various degrees of

cold work with unpredictable dimensional change during heat treatment. Another material property is grain structure. A uniform grain structure is desirable for predictable distortion. Furthermore, the nonmetallic inclusions in the material need to be minimized, preferably by selecting vacuum-melted steels. Low inclusions make the mechanical properties of vacuum-melted steels far superior to the air-melted variety. In the following section, the primary advantages and limitations of vacuum-melted steels are discussed in detail. Also, it is important that gears of the same material heat code provided by steel mills are processed together to maintain uniform heat treat response.

**Material cleanliness** is an important criterion that needs to be considered for acceptable quality of gear materials. Also, material cleanliness plays an important role that determines the consistency of heat treat response. The cleaner the material (low nonmetallic inclusions) is, the more predictable the heat treat distortion of gears. The degree of cleanliness usually is controlled by an Aerospace Material Specification (AMS). Of the various applicable specifications, AMS 2300, AMS 2301, and AMS 2304 are frequently applied to gear materials. These specifications also call for strict magnetic particle inspection standards to control surface integrity. AMS 2300 specifies the highest cleanliness standard and can only be achieved in vacuum arc remelt (VAR) steels. On the other hand, AMS 2301 quality steels are generally achieved by air melting, whereas AMS 2304 quality may be attained either with VAR or air melting under strict control of nonmetallic inclusions.

Sometimes, AMS 2300 quality steels are not readily available because of strict control of inclusions. Thus, it may create some unacceptable bottlenecks in manufacturing. Also, in-house inspection of such materials presents quite a bit of difficulty for gear manufacturers not equipped with proper measuring equipment. Furthermore, these materials are not easily machinable due to lack of sufficient sulphur, which causes cutting speeds and feeds to be slowed down considerably. Even then, high stresses may be induced in the gears during machining. For predictable heat treat distortion, it is thus a good practice to stress relieve gears made of these materials before any heat treatment. In addition, experimental results show that material cleanliness affects some important mechanical properties such as allowable contact fatigue stress and bending fatigue stress in gears.

This knowledge made the American Gear Manufacturers Association (AGMA) specify different cleanliness standards for three different grades of materials:

- Grade 3 materials call for AMS 2300. Gears made of these materials are used in critical applications. Allowable contact fatigue stress is 1900 MPa (275 ksi).

- Grade 2 materials call for AMS 2301. Gears used in these applications are not as critical as those made of grade 3 materials but have been successfully used in high-speed applications up to 185 m/s (36,000 ft/min). These materials are easy to machine and procure. Cost/pound is significantly lower than grade 3 materials. Allowable contact fatigue stress is 1550 MPa (225 ksi).
- Grade 1 materials do not specify any special cleanliness quality and non-metallic inclusions may vary widely. A great percentage of industrial-type gears are made with these materials. Allowable contact fatigue stress for such steels is 1240 MPa (180 ksi). A major disadvantage with this grade of materials is significant uncontrolled heat treat distortion of gears.

Although there is no separate AGMA grade for materials that meet AMS 2304, their mechanical properties are far superior to AMS 2301 quality materials. Allowable contact fatigue stress may be considered to be similar to grade 3 materials. Also, heat treat response of these materials is as predictable as AMS 2300 materials. Besides, AMS 2304 materials are easily available and their cost/pound is less than AMS 2300 materials. All of these features sometimes make AMS 2304 material quite attractive even for some critical applications. The chemical analysis, followed by Jominy and microcleanliness results, of a typical AISI 9310H steel used for high-speed pinion of a speed increasing gearbox for gas turbomachinery applications that meet AMS 2304 is presented subsequently. An electric furnace, vacuum degassed, ladle refined, was the melt method used. Grain size was 7, tempered at 620 °C (1150 °F) for 9 h. The oxygen part per million (OXPP) was 20; the bismuth level, 0.002.

Element (Heat No. D8628)	Percent	Element (Heat No. D8628)	Percent	Element (Heat No. D8628)	Percent
Carbon	0.12	Silicon	0.32	Aluminum	0.028
Manganese	0.63	Nickel	3.46	Vanadium	0.049
Phosphorus	0.009	Chromium	1.38	Copper	0.14
Sulfur	0.015	Molybdenum	0.14		

Jominy results were as follows:

Distance from quenched end, in $\frac{1}{16}$ in.	HRC	Distance from quenched end, in $\frac{1}{16}$ in.	HRC	Distance from quenched end, in $\frac{1}{16}$ in.	HRC
1	39	8	39	20	35
2	39	9	39	22	35
3	39	10	39	24	34
4	39	12	38	26	33
5	39	14	37	28	33
6	39	16	36	30	33
7	39	19	36	32	33



The assessment of microcleanliness of materials generally is carried out per ASTM A 534, which has inclusion ratings as follows:

Inclusion	Rating	
	Thin (T) series	Heavy (H) Series
A	2.5	1.5
B	2.0	1.0
C	0.5	0.5
D	1.0	1.0

The forgings used in this case had microcleanliness ratings as follows:

Inclusion	Thin (T) series	Heavy (H) series
A	1	1
	1	0.5
	0.5	0.5
	1.5	1
	1	1
B	0.5	0.5
	0.5	1
	0.5	...
	0.5	...
	0.5	...
C	0.5	...
	...	...
	...	...
	...	...
	...	...
D	0.5	...
	0.5	...
	0.5	0.5
	0.5	0.5
	0.5	...

The amount of inclusions indicates the material used to meet AMS 2304/E 9-45.

**The Hardenability of Steel.** Steels with higher hardenability, in general, experience more heat treat distortion. On the other hand, lower hardenability steels exhibit low distortion but may not meet the design requirements.

**Alloy Elements.** The higher the alloy content, the larger the heat treat distortion will be.

**Method of Quenching.** Direct quenching results in lower distortion. However, distortion may increase when gears are cooled after carburizing and then reheated before quenching (double heating cycle and related thermal stress).

**Flow of Quench Media.** Whether oil or gas, an insufficient and turbulent quenchant flow increases distortion because of slow heat transfer between the gears and quench media.

**Temperature of Quench Media.** Low quench media temperature increases thermal shock and gear distortion. High quench temperature reduces distortion but may not produce acceptable case properties.

**Speed of Quench Media.** Low-speed oil media (16 s and lower) causes higher distortion. Higher than 18 s is suitable for low distortion but may not produce the desired case microstructure.

**Gear Blank Design (Solid or Webbed Construction).** Solid construction seems to have smaller distortion than the webbed configuration. However, larger gears are usually webbed in order to reduce weight and often have asymmetric sections as well. Distortion of this type of gear blank could be large. Again, webbing is needed for uniform heat treatment tooth along the face width. Without web, the center of tooth does not have the same metallurgical properties as the end of a tooth as depicted in Fig. 5.28.

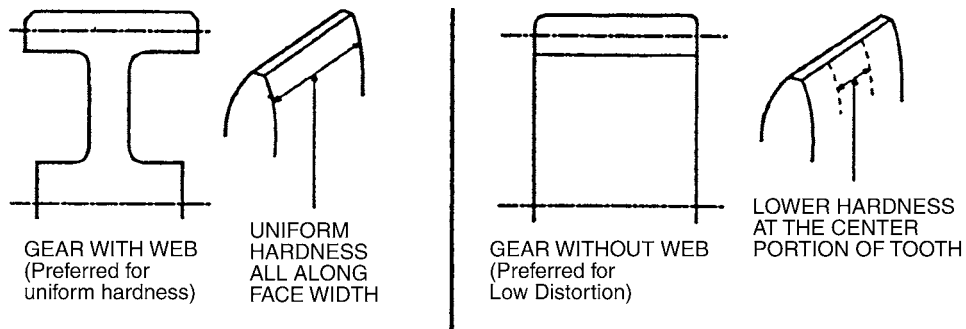
### ***Vacuum-Melted versus Air-Melted Alloy Steels***

Because of high strength, ductility, and toughness, alloy steels are frequently used for gears, particularly in aerospace and other critical applications. These steels are available in either vacuum- or air-melted condition. Vacuum-melted steels have fewer nonmetallic inclusions, are much cleaner than the air-melted variety, and offer several advantages as discussed previously. Even then, gear engineers are reluctant to use these types of steel due to higher material cost per pound without any consideration for the total manufacturing cost. In the author's experience, vacuum-melted steels offer optimum designs in several applications just because of low heat distortion that significantly reduces gear grinding time. Also, the rejection rate of gears after carburizing for improper microstructure of case is very low. It is advisable, therefore, to consider all pros and cons before selecting a proper gear material. To enable design

engineers to decide on the type of material, it is considered helpful to summarize the major benefits of vacuum-melted steels:

- Lower unwanted gas content
- Fewer nonmetallic inclusions
- Less center porosity and segregation
- Increased transverse ductility
- Increased fatigue properties

Typical average gas contents (wt%) of two widely used steels before and after consumable electrode vacuum melting, as determined by the vacuum fusion technique, are shown in Table 5.11. It can be seen that the gas contents of AISI 4340 and 9310 steels have been reduced to extremely low levels by vacuum melting. The low hydrogen content in steels reduces the susceptibility to flaking, while the low oxygen content



**Fig. 5.28** Effect of gear blank web on uniformity of tooth hardness

**Table 5.11** Gas contents of two gear steels before and after consumable electrode vacuum melting

Alloy	Gas content, wt%					
	Before vacuum melting			After vacuum melting		
	H <sub>2</sub>	O <sub>2</sub>	N <sub>2</sub>	H <sub>2</sub>	O <sub>2</sub>	N <sub>2</sub>
AISI 4340	0.00014	0.0025	0.010	0.00009	0.0004	0.0053
AISI 9310	0.00019	0.0035	0.011	0.00008	0.0006	0.0072

reduces the amount of oxygen available for formation of nonmetallic inclusions.

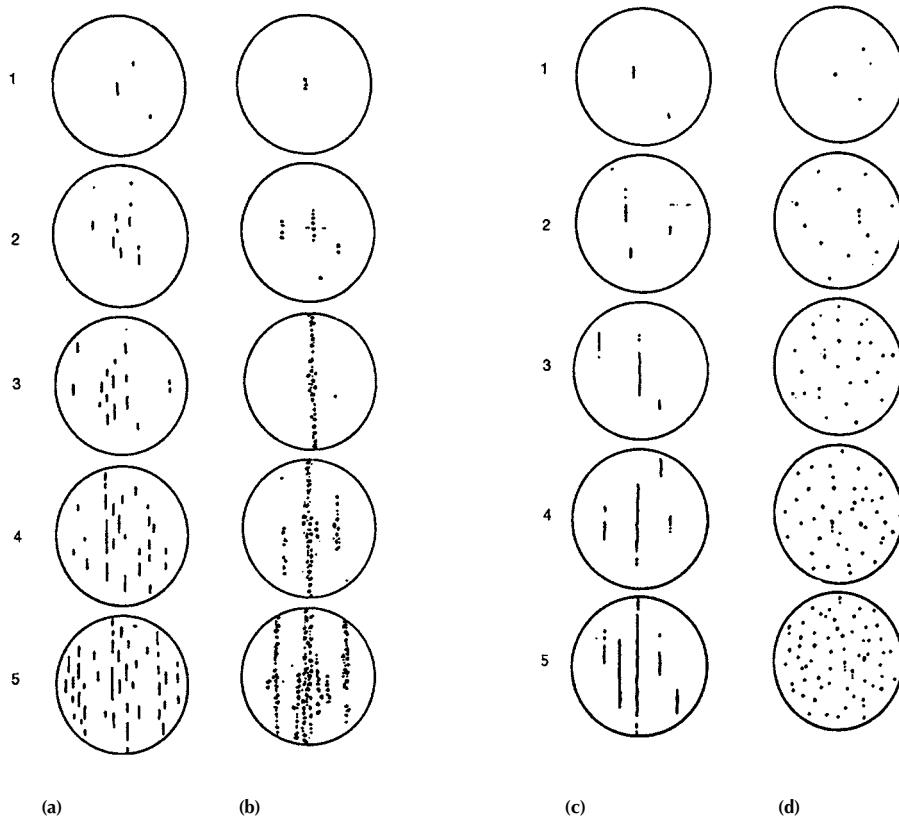
There are two methods available for comparing the cleanliness of vacuum-melted and air-melted steels. One is the magnetic particle test that has been extensively used in the aircraft industry for rating steels such as AISI 4340 and 9310. The other method for rating cleanliness is thorough microexamination, whereby the number, sizes, and types of nonmetallics are counted.

The magnetic particle inspection of vacuum-melted steel requires that indications of inclusions as small as 0.40 mm ( $1/64$  in.) long be counted, whereas, in testing air-melted steel, it is required only to count indications down to 1.6 mm ( $1/16$  in.) in length. A comparison of vacuum-melted, and air-melted heats of AISI 4340 and 9310 steels was made where indications down to 0.40 mm ( $1/64$  in.) in length were counted in the steel produced by both vacuum and air melting. In every case, the vacuum-melted steels were 5 to 10 times cleaner than the air-melted products. The Jern Konntoret (JK) chart (Fig. 5.29) is presently the basis for rating cleanliness of steels. Row 1 in this figure shows the least inclusion, while row 5 has the highest.

Improvements in fatigue resistance are directly related to the cleanliness of steel. It has been shown that large nonmetallic inclusions lower the fatigue strength of a metal. In vacuum-melted steels, there are no large nonmetallic inclusions. This increases their fatigue strengths. The transverse ductility of steels produced in a vacuum also shows improvement, especially at the ultra-high-strength level. The improvement in transverse ductility of AISI 4340 (AMS 6485) and 300M steels after vacuum melting is denoted by higher elongation as shown in Table 5.12. These materials are extremely brittle at the 2070 MPa (300 Ksi) strength level in the air-melted condition; however, after consumable electrode vacuum melting, they have sufficient transverse ductility to be fabricated into aircraft landing gears and missile components. The higher, more uniform quality of the consumable-electrode vacuum-melted steels makes them popular for aerospace applications where fatigue life (over 10 billion cycles) and high reliability are frequently a requirement.

**Cost of Material.** Although air-melted steel costs are approximately 50% less, the use of VAR steels permits cost savings in several areas:

- Magnetic particle test rejections are reduced to almost zero. Each finished gear that is scrapped due to mag-particle inspection represents a loss of 10 to 30 times raw material cost.
- VAR material would eliminate the need for forged blanks in gear sizes under 130 mm (5 in.) outside diameter. Forging dies and forgings are a significant cost item in gears.
- VAR material can be procured with about three times closer control on chemical composition. Heat treat practice, a high source of gear



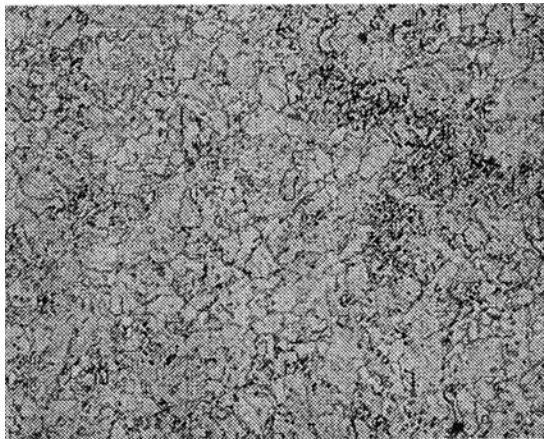
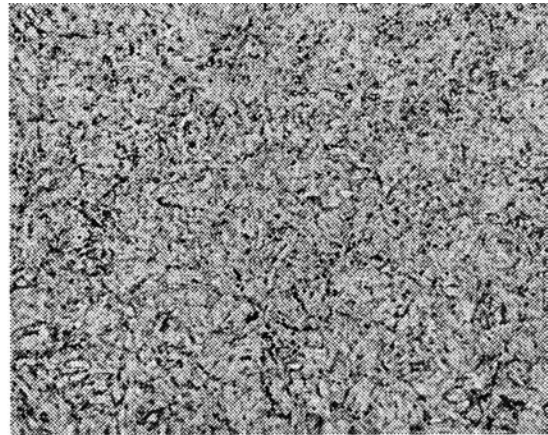
**Fig. 5.29** Jern Konntoret (JK) chart for determining the inclusion in steel. (a) Sulfide-type inclusion. (b) Alumina-type inclusion. (c) Silica-type inclusion. (d) Globular-type inclusion. Courtesy of Republic Steel Corporation, Cleveland, Ohio

rejections, can be much more easily perfected by having large quantities of steel that are almost exactly the same composition and hardenability.

- Problems of “banding” (grains not properly diffused in certain areas of a forging or rolled bar) and alloy segregation can be eliminated. In gear blanks made of air-melted steels, such a condition may exist. This type of banding is the result of improper solidification of steel in an ingot as illustrated in the micrograph (Fig. 5.30) of an AISI 4340 steel forging and may cause reduced core hardness in the range of 1 to 2 points in HRC scale. Minor banding as illustrated in Fig. 5.30 is generally eliminated during subsequent heat treatment, particularly normalizing and austenitizing as diffusion occurs during these processes. Severe banding that occasionally exists in air-melted steels destroys material microstructure, and the hardness may be reduced as high as 10 HRC points, which are detrimental to gear life.
- Early failure of a gear due to undetected nonmetallic inclusions is minimized.

**Table 5.12 Comparison of transverse mechanical properties between air-melted and consumable-electrode, vacuum-melted steels**

Alloy	Type of melt	Tempering temperature, °C (°F)	Tensile strength, MPa (ksi)	Yield strength, MPa (ksi)	Elongation, %	Reduction of area, %
AISI 4340	Air	230 (450)	1944 (282)	1586 (230)	6.0	14
		480 (900)	1379 (200)	1193 (173)	8.0	16
		538 (1000)	1241 (180)	1103 (160)	10.0	22
	Vacuum	230 (450)	1931 (280)	1634 (237)	6.5	17
		480 (900)	1379 (200)	1207 (175)	9.0	20
		530 (1000)	1241 (180)	1103 (160)	10.5	24
300M	Air	315 (600)	1958 (284)	1620 (235)	5.0	11
		425 (800)	1758 (255)	1538 (223)	7.0	14
		538 (1000)	1586 (230)	1482 (215)	9.0	22
	Vacuum	260 (500)	2020 (293)	1620 (235)	7.0	25
		425 (800)	1758 (255)	1551 (225)	10.0	34
		538 (1000)	1586 (230)	1482 (215)	11.0	35

**Mag: 200X Nital Etch****Mag: 1000X Nital Etch****Fig. 5.30** Banding in a gear forging made of AISI 4340 steel

- VAR material gears carry more load than air-melted steels because there is only about  $\frac{1}{20}$  the amount of macro and micro impurities present. Allowable gear rating could be raised when VAR material is matched up with a skilled and disciplined heat treat practice. For example, a 1200 hp gearbox (gears made of air-melted steel) may be upgraded to transmit 1500 hp with the same center distance if gears are made of VAR steels, provided other components such as bearings and shafts in the gearbox can carry the additional load.

### **Measurement of Gear Distortions**

The distortion associated with gears is usually characterized by the following changes in gear geometry:

- *Profile change*: Due to greater growth near the root of gear teeth than at the tips giving the appearance of collapsed tips
- *Lead change*: A condition, experienced quite often, with gears of wide face width resulting in a change of tooth helix angle (spur gear tooth: 0° helix angle)
- *Size change*: Determined by measurements of pitch diameter (PD) before and after heat treatment. Change in dimension over or between pins bears a direct relationship with the change in PD of gears.
- PD runout
- *Change in blank dimension*: Flatness of rim and hub

### ***Some Recommendations to Minimize Distortion***

**Material** needs to be as clean as possible (AMS 2300 or 2304), preferably vacuum melted and of homogeneous composition—alloy segregation or banding is to be avoided. AMS 2300 is highly recommended for cleanliness. If difficulty is experienced in procuring material under this specification, then AMS 2304 may be considered.

**Lot Verification.** The material in each lot of gears shall conform to the specification on the drawing. A lot shall consist of gears of one part number, manufactured from one heat of steel, and should not be mixed with another heat of steel during heat treatment. Each part must be identified with the lot number.

**Heat Verification.** Verification of conformance of heat for the steel shall be performed prior to manufacture of gears. The verification shall include chemical analysis, hardenability check, magnetic particle inspection rating, microinclusion rating, and macroetch examination, as applicable.

**Grain Flow.** When a forging is required for an application, the forge die and upset ratio shall be determined by examination of a sample forging prior to production. Evaluation for approval shall be made on a section cut through the centerline, or longitudinal axis of the sample forging. After approval, the forge die and upset ratio shall not be changed. Figure 5.31 shows some acceptable and unacceptable grain flow patterns in a gear forging. Grain flow parallel to gear axis is not acceptable.

**Proper normalizing** of material is essential prior to machining with subsequent microstructure analysis for verification. It is an important operation for uniformity of grain structure. It is carried out by heating gears to the austenitic region and then cooling in “still air.” The normalizing temperature should be selected to slightly exceed the carburizing temperature, so that grain size changes will not again occur during carburizing. Normally, carburizing is performed between 870 and 930 °C (1600 and 1700 °F) for which an optimum normalizing temperature would be between 940 and 950 °C (1725 and 1750 °F).

Materials after normalizing with hardness above acceptable machining range (HRC 34) may be annealed at a lower temperature to obtain proper hardness. Grain size between ASTM 5 and 7 (Fig. 5.32) after normalizing is quite effective for low distortion. Test coupons must accompany parts.

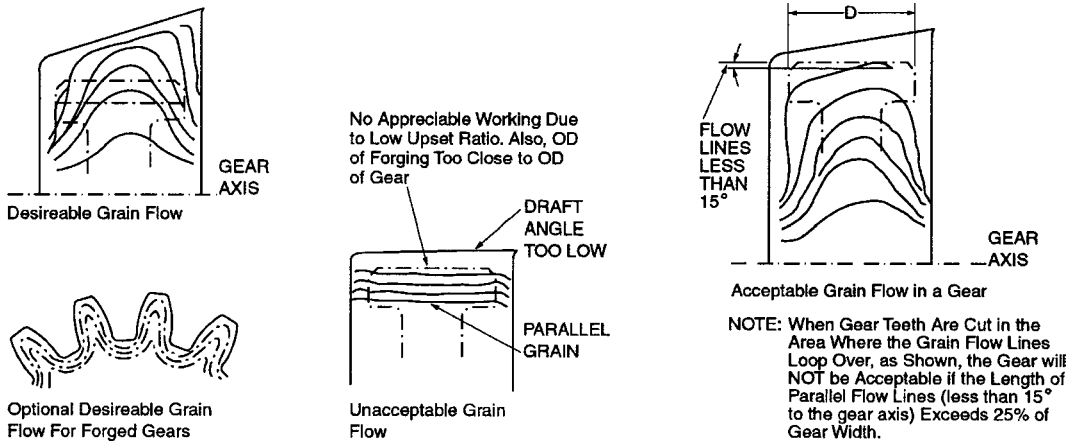


Fig. 5.31 Acceptable and unacceptable grain flow in a gear forging

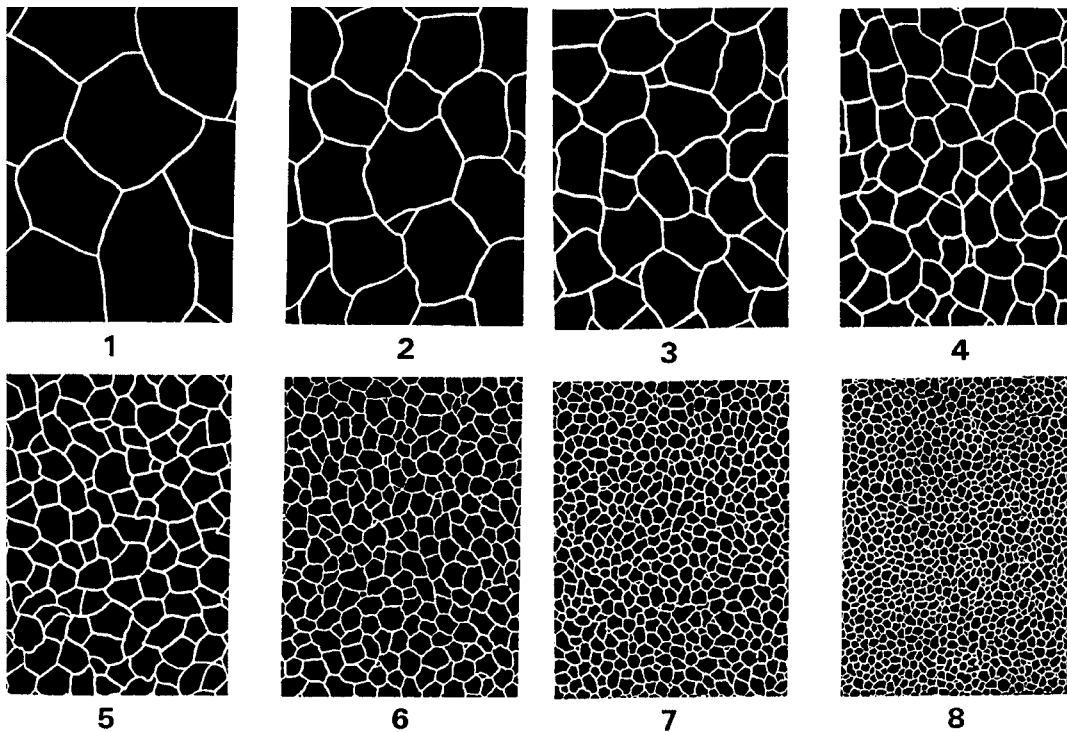


Fig. 5.32 Standard ASTM grain sizes of steel

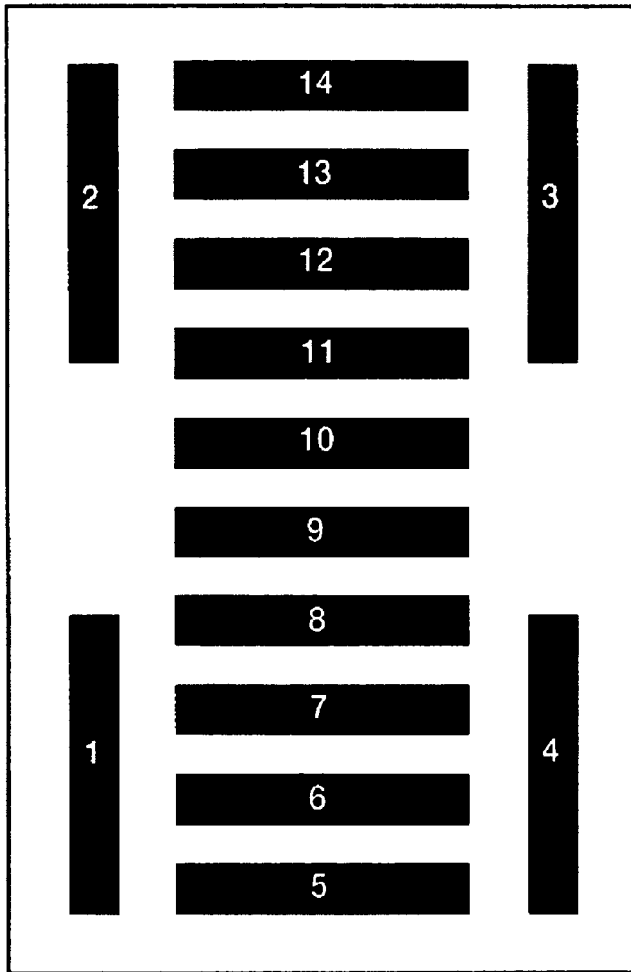


**Normalizing refines grain structure**, whereas annealing reduces hardness. Gears may be normalized before or after rough machining. An adequate normalizing procedure is as follows:

1. Load the part into a furnace that is at or below 870 °C (1600 °F), if part is of uniform section size. Limit the furnace temperature to 540 °C (1000 °F) maximum, when loading a part with more than one section thickness (to avoid cracking).
2. Furnace temperature rise shall not exceed 170 °C (300 °F) per hour.
3. Normalizing temperature will be between 940 and 950 °C (1725 and 1750 °F)—slightly above the carburizing temperature planned, not by more than 30 °C (50 °F).
4. Hold at temperature for ½ h per inch of maximum section thickness or 2 h, whichever is greater.
5. Remove from furnace and allow to cool in still air. Do not accelerate or inhibit air movement.
6. Stress relieve before gear cutting. Stress relief is also suggested after rough gear cutting for gears below 5 DP.
7. Uniform carburizing atmosphere: The entire load needs to be at a narrow temperature band (930 ± 8 °C, or 1700 ± 15 °F) to ensure uniform result. The vacuum furnaces are generally capable of maintaining temperature within ±6 °C (±10 °F) in the work zone.
8. High, uniform laminar flow (225 to 300 L/min, or 60 to 80 gal/min, for each 0.45 Kg, or 1 lb, of gears) of quench oil, preferably an oil that allows quenching at approximately 120 °C (250 °F) for acceptable hardness profile of gear teeth; gas quench if carburized in a vacuum furnace.
9. Speed of oil: approximately 18 s
10. Press quench: This and other means of quenching in fixture such as plug, and cold die are the most effective methods used to keep the gears flat and minimum PD runout.

**Load arrangement in the furnace** has a significant effect on the outcome of directly quenched gears. Small, lightweight, more intricate gears should be loosely hung on rods mounted on special carburizing fixtures or laid flat on their faces. Larger and heavier gears should either rest vertically on their teeth with overhead wiring for added stability or lie flat on the faces.

**Another factor to consider** when arranging a load for heat treatment in an in-and-out furnace is the distortion caused by the way a gear load is arranged. It may be necessary to experiment in order to find the best method suitable for the gears in question. In one load arrangement (Fig. 5.33), 510 mm (20 in.) outside diameter (OD), 98 tooth spur gears made from forging (AISI 8620) with 13 mm (½ in.) face width, gears numbered 1 through 5 and 14 distorted excessively, while those numbered



**Fig. 5.33** Arrangement of 510 mm (20 in.) OD spur gears in a carburizing furnace

6 through 13 did not. During the production run, instruction was given not to place gears in the positions with excessive distortion. This improved overall quality of gears after heat treatment.

In addition to these factors, control of the carburizing process itself is considered vital for effective carburizing with minimum distortion. There are many ways in which a carburizing furnace and its controls can malfunction. For instance, failure of a thermocouple can cause the process to go out of control; soot buildup in the furnace can interfere with carburizing reactions. An operator can detect these and many other relatively common occurrences and take corrective action before there is an adverse effect on parts in the furnace. The following is a partial check list of items to be considered in setting up the furnace for production:

- *Temperature distribution:* No hot or cold spots in the furnace are acceptable. Thermocouples need to be properly installed.
- *Variation of carbon concentration:* Test bars for carbon determination should be placed at varying locations on trays with gears to be carburized. Results of preliminary tests are to be analyzed statistically to ascertain the process capability of the furnace.
- *Carburizing atmosphere:* For shallow cases, most of the enriching gas is to be delivered into the furnace close to the discharge end. For deep cases, it is to be nearer to the charging end, keeping in mind that in either instance, the enriching gas should enter at the point where the work load has reached the carburizing temperature.
- *Dew point control:* It should be ascertained whether the last furnace zone (diffusion zone) can develop the required dew point, with some latitude for adjustment. A small, measured quantity of air may be introduced to increase the dew point and lower the carbon potential.

### ***Preheating of Gears***

It is advisable to preheat gears prior to loading into a carburizing furnace. This process generally is done in a draw furnace. Preheating helps to control distortion that results from introducing gears from room temperature directly to the austenitizing temperature.

### ***Distortion Characteristics of Some Gear Materials***

As mentioned in previous chapters, the distortion characteristics of carburizing grade gear materials depend on a large number of variables. Recent research work on distortion of high-strength steels suggests the degree of distortion depends not only on the steel composition, but also on the type of heat treat process. For example, the step quenching, or so-called ausbay quenching, significantly reduces distortion by as much as a factor of three compared with normal quenching procedure. Furthermore, heat treating the steel to a bainitic structure compared with martensitic structure reduces the degree of distortion. Table 5.13 shows comparative distortion ratings of some commonly used carburizing grade gear steels in industrial and aerospace applications.

An analysis of data presented in Table 5.13 shows gear materials that exhibit good mechanical properties with acceptable distortion generally cost more than materials with higher distortion. But the finishing cost of gears made of high distortion materials is significantly higher. Thus, it is important to consider all aspects before selecting a proper gear material. From mechanical properties, manufacturing, and cost points of view, AISI 9310 is considered to be one of the best materials currently available. This material is available both in vacuum- and air-melted conditions. Vast field data of successful applications are also available. However, AISI 8620 steels are extensively used for industrial gears because of their low cost. It is found that gears up to 410 mm (16 in.) OD made of these materials

**Table 5.13 Distortion ratings of common gear materials**

Material	AMS specification	AMS quality	Quench media	Hardness, HRC		Distortion rating(a)
				Case	Core	
AISI 8620	6276, 6277	2304	Oil	58–60	28–32	Fair
AISI 9310/9315	6265(b), 6414(c)	2300/2304	Oil	58–62	34–42	Fair
AISI 4320	6299	2300/2304	Oil	58–60	36–40	Fair
AISI 4330 M(e)	6411, 6429	2300	Oil	58–62	42–50	Poor
AISI 4130	6370	2300/2304	Oil	58–62	34–42	Poor
HP 9-4-30(e)	6526	2300	Oil	58–62	48–52	Good
M50 Ni1	6490D	2300	Oil	58–62	35–45	Good
VASCO X2M	N/A(d)	2300	Oil	58–62	38–44	Good
CBS 600	6255	2300	Oil	58–62	34–42	Good
AISI 4620	6294	2300/2304	Oil	58–62	34–40	Poor
Pyrowear 53	6308	2300	Oil	59–64	36–42	Good

(a) Distortion ratings: poor, degradation of AGMA quality by 2 to 3 classes; fair, degradation of AGMA quality by 1 to 2 classes; good, degradation of AGMA quality by 0 to 1 class. (b) AMS 6265, consumable electro-vacuum-melted steel. (c) AMS 6414, consumable electro-remelted steel. (d) N/A, not available. (e) Effective case depth determination is difficult due to high core hardness of these materials.

could maintain AGMA class 9 gear quality after carburizing and hardening. A case history of an investigation to achieve this quality with hobbled and shaved gears is given in a case history at the end of this chapter.

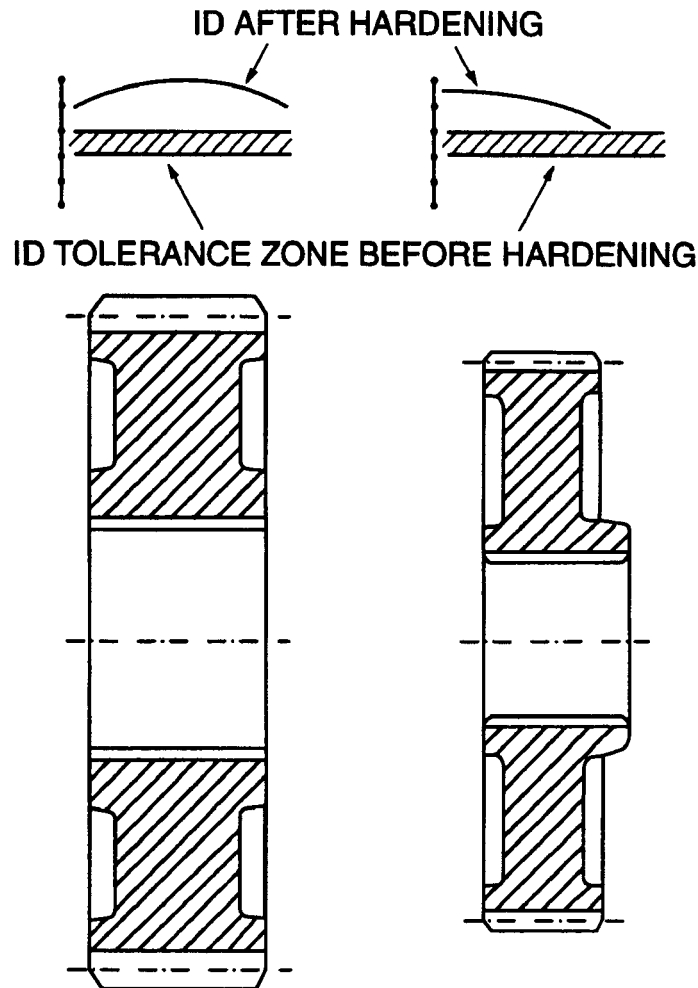
### ***Improvement in Gear Design to Control Heat Treat Distortion***

Gear blank design has a profound effect on distortion. To minimize distortion, blank design should address not only uniform metallurgical properties of teeth along the face width but also distortion. For example, gear blanks as depicted in Fig. 5.34 are found to distort more than blanks shown in Fig. 5.35 under similar heat treat conditions. Holes and reduced mass are beneficial for good heat treatment and low distortion. Pinion teeth with blank ends as illustrated in Fig. 5.36(a) seem to have large distortion of lead. Such distortion can be minimized with a small properly designed relief at the end of the teeth as shown in Fig. 5.36(b).

**Carburizing of Long Slender Pinions.** In this type of pinion, Fig. 5.37(a), after carburizing and hardening, in addition to distortion of tooth geometry, the shaft bows. Such a bow can be minimized by press or die quenching the pinions. Furthermore, if the design of the pinion is such that the teeth are located at the center of shaft, they will experience the maximum bow as illustrated in Fig. 5.37(b). Because the teeth need to be ground for higher quality (AGMA class 10 and above) with respect to the centerline of bearing journals, which are at the minimum bow position, grinding may remove most of the case from the teeth. To ensure minimum case removal from teeth after grinding, pinion shafts of this type are sometimes straightened under a press before grinding of the journals and teeth with proper control. An uncontrolled straightening operation could damage the parts for the following reasons:

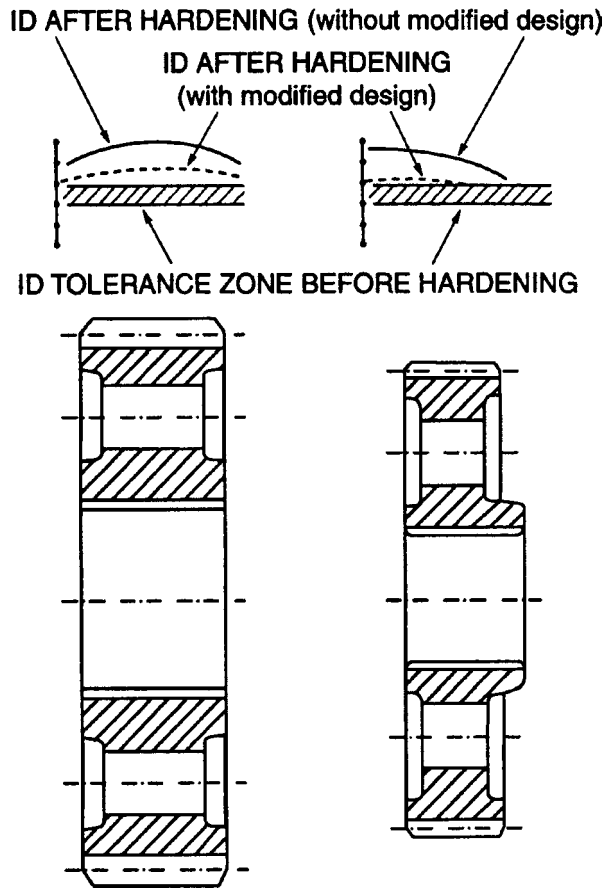
- Stress induction during straightening may initiate cracks in the hard case.
- After straightening, the part can be in an unstable condition and is likely to return, at least partially, to its unstraightened shape when put into service, causing improper contact between meshing teeth that may deteriorate gear life.

Because straightening is such a potentially damaging and expensive operation, everything practical should be done to eliminate the need for it. If it is still necessary, a reasonably satisfactory solution to the problem is to heat the parts to just below tempering temperature and straighten, followed by air cooling to room temperature. All parts shall then be magnetic particle or dye penetrant inspected for cracks.

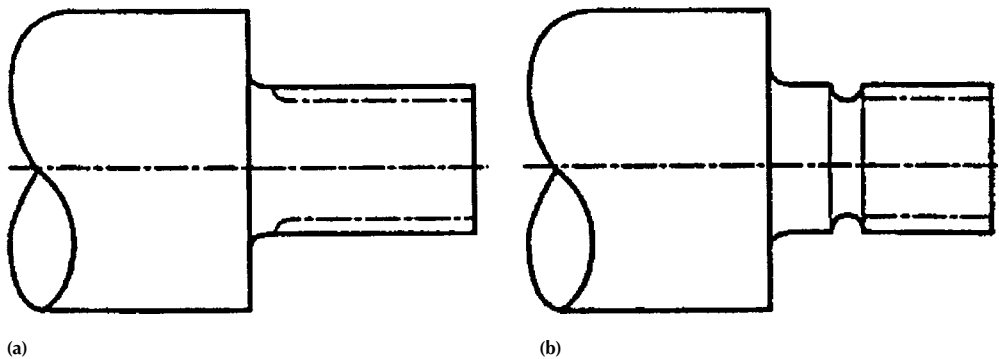


**Fig. 5.34** Standard gear blanks for high distortion

**Dumb-Bell Shape Pinion.** The design as illustrated in Fig. 5.38 presents a high degree of difficulty in controlling heat treat distortion after carburizing and hardening. For acceptable distortion, the ratio between largest and smallest outside diameters in the shaft is recommended to be



**Fig. 5.35** Improved gear blanks for low distortion

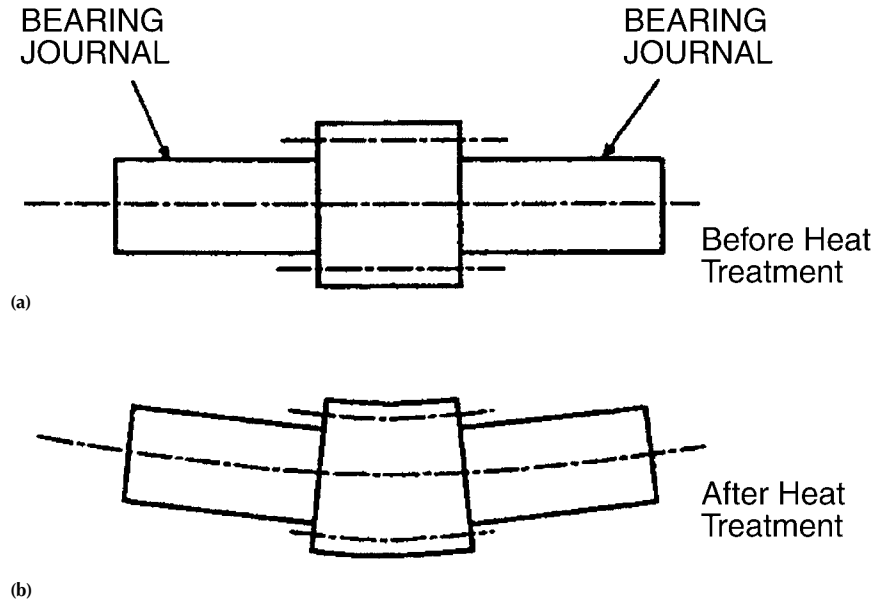


**Fig. 5.36** Improved pinion design for low distortion. (a) Original design (blind end teeth). (b) Improved design (open end teeth)

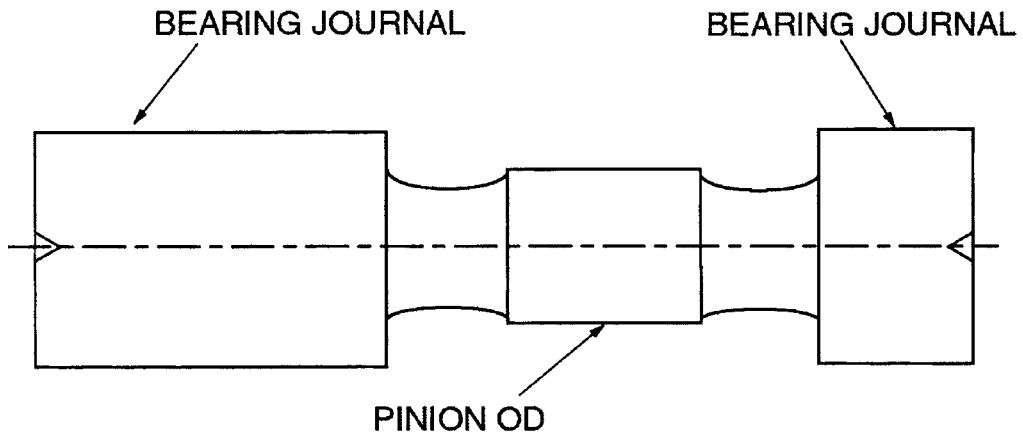
less than 1.5:1. Pinion configuration of this type should be avoided, if possible.

**Blank Design for Uniform Hardness of Wide Face Width Gears.**

Of the various parameters that control the heat treat quality of carburized and hardened gear teeth, the rate of heat transfer between the teeth and

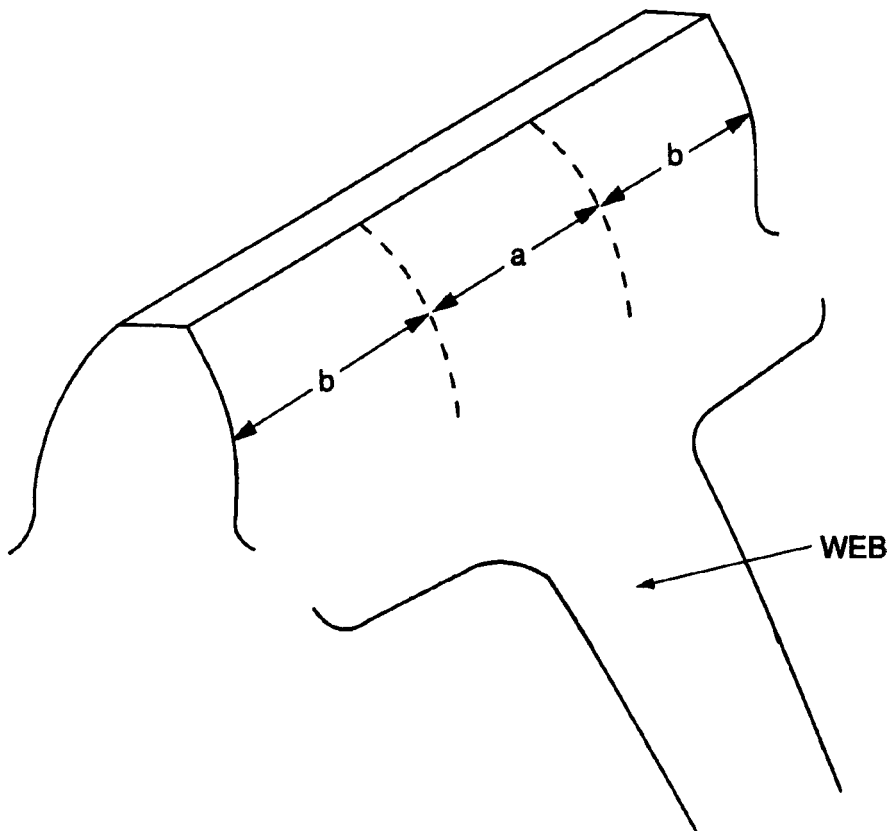


**Fig. 5.37** Distortion of slender pinion. (a) Before heat treatment. (b) After heat treatment



**Fig. 5.38** Pinion blank-dumb-bell-type configuration

quench media plays an important role. In general, besides material hardenability, fast heat transfer results in acceptable surface hardness, effective case depth, and core hardness of gear teeth. In achieving these properties, configuration of the gear blank (with or without web), size of gear, face width of tooth, and DP also contribute significantly. Design of a gear blank with or without web depends largely on the form of material used—bar or forging. Bars are used for small gears, whereas large alloy steel gear blanks (above 30 mm, or 10 in., diameter), in particular for high production, are made primarily from forgings with web. Occasionally, for small production quantities, large gear blanks with web are machined out of “pancake” forgings. In any case, when large gears with or without web are carburized and hardened, hardnesses at the surface and core, and case depth are found to be lower at the center region “a” of tooth face width (Fig. 5.39) than at the outer regions “b.” Figure 5.40 illustrates an approximate difference in surface hardness versus case depth gradient at “a” and “b”. On the other hand, such a difference is not greatly pronounced in small gears (less than 30 mm, or 10 in., diameter) because of their smaller mass. Nevertheless, with high  $l/d$  (face width/pitch diameter) ratio over 1.5:1, lower case depth and hardness result at the



**Fig. 5.39** Typical webbed gear tooth

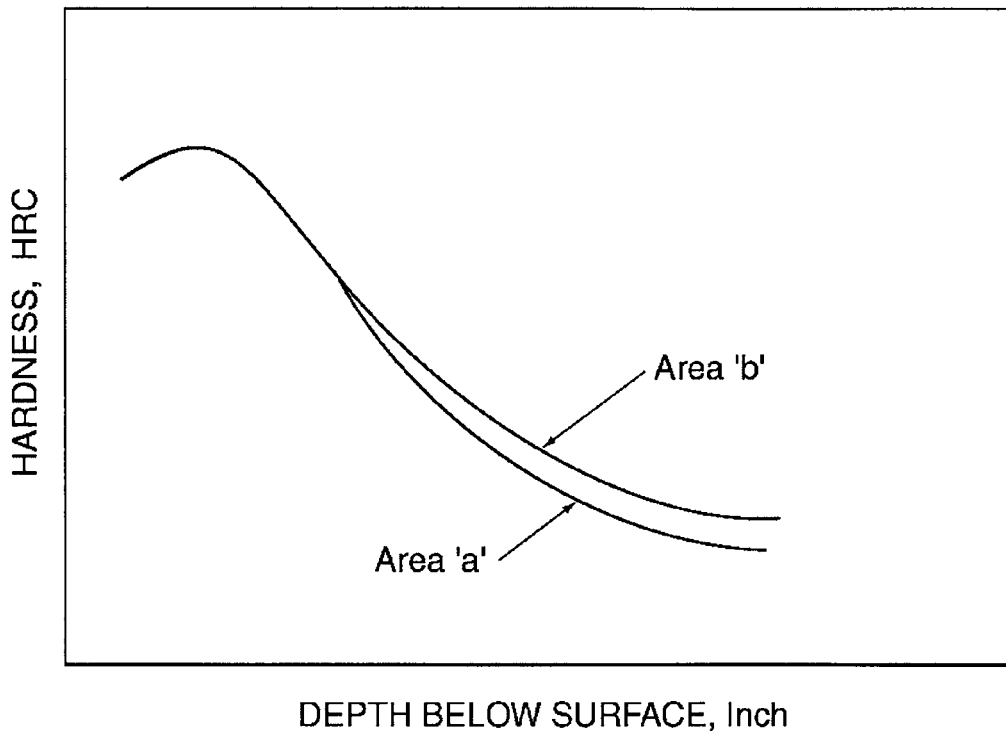


center region of teeth in all gears, large or small, the variations being quite distinct in large gears.

The cause of lower effective case thickness and core hardness is attributed mainly to differential heat transfer rate during quenching—slowest at the center region. Large mass of the web below the center region acts as a barrier to fast heat transfer rate required for high hardness and uniform case depth along the face width. Without web (solid blank) the differential heat transfer extends from the outer ends to the center region of teeth that results in higher hardness and case depth at the ends gradually decreasing toward the center.

Although small variations in hardness and case thickness along the face width may not be of any concern for gears in industrial applications, these can play an important role in ensuring the reliability of carburized and hardened gears in critical applications. An improvement to the blank design is recommended to ensure both uniform hardness and case depth along the face width of gears.

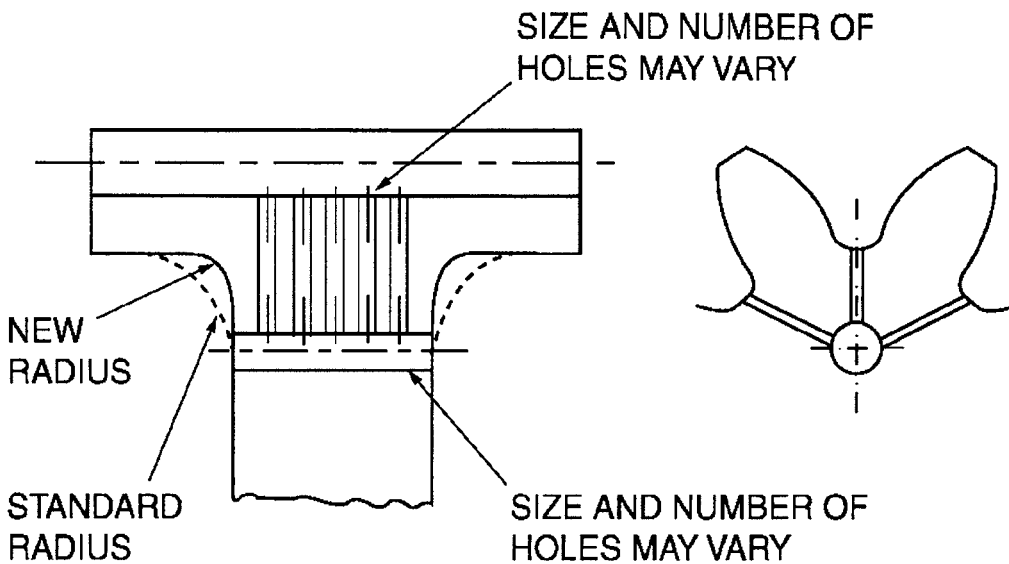
This can be partly achieved by designing a blank with a small fillet radius at the web that is acceptable from a stress concentration point of view. Also, heat transfer from the middle section of the tooth could be improved by drilling small holes in the tooth spaces as illustrated in



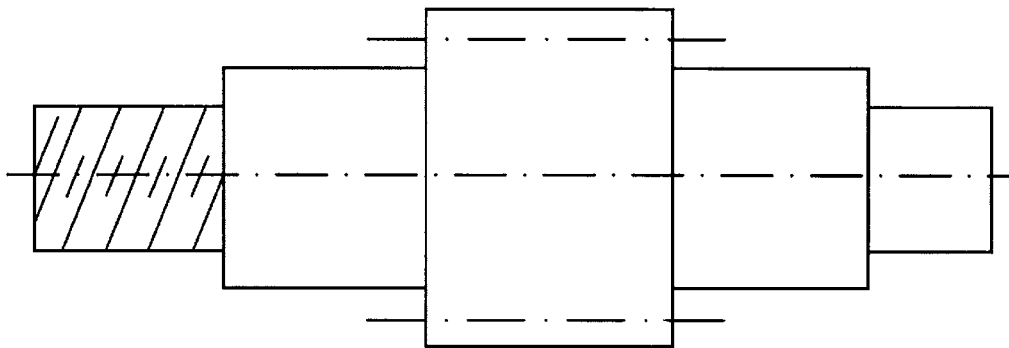
**Fig. 5.40** Surface hardness vs. case depth at different locations of a tooth along face width

Fig. 5.41. Small fillet radius and holes in tooth spaces not only improve uniformity of case and core hardnesses along the face width of tooth but also provide better lubrication, especially in high-speed gearing with pitch line velocity above 50 m/s (10,000 ft/min).

**Pinion Shaft with Threads.** The threads on a pinion shaft as depicted in Fig. 5.42 grow and distort similar to pinion teeth after carburizing and hardening to the extent that may require the threads to be ground. To eliminate such a costly operation, it is advisable not to carburize the threads, which could be achieved either by copper plating or covering with noncarburizing-type solution before carburizing. Any small distort-



**Fig. 5.41** Drilling of blank for uniform core hardness



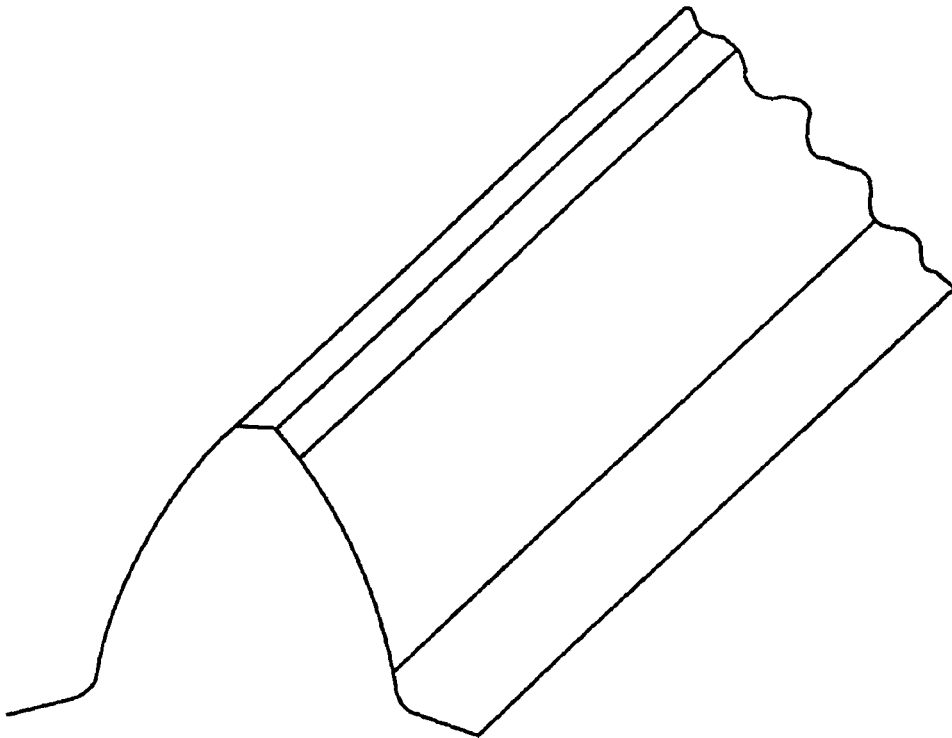
**Fig. 5.42** Pinion design with threads in the shaft

tion during heat treat process may be removed by thread chasing, a fairly inexpensive operation compared with grinding.

**Heat Treat Cracks at Tooth Edges.** In helical gears, unchamfered tooth edges, which, in particular, form acute angles with face width (Fig. 5.43) are frequently found to develop microcracks after carburizing and heat treatment. These types of cracks are more pronounced on the side that enters the quench media first (Fig. 5.44). This is due to high thermal shock and stress—the cooler the quench media, the higher the shock.

Experimental investigations showed that cracks emanating from the tooth edges could be avoided by a proper chamfer (Fig. 5.45) that helps to eliminate the sharpness of the acute angle edges. In chamfering the tooth edges, it is important to note that the amount of chamfer may not be equal on the acute and obtuse angle sides—smaller on the edge with the acute angle. Because cracks are found primarily on the edge with acute angle, chamfering on this edge is important. The following chamfer dimensions are found to be adequate and recommended for avoiding cracks from tooth edges of helical gears:

- *4 DP and lower:* 1 mm (0.04 in.)  $\times$  45°
- *Above 4 DP:* 0.75 mm (0.03 in.)  $\times$  45°



**Fig. 5.43** Helical tooth without chamfer on tooth edges

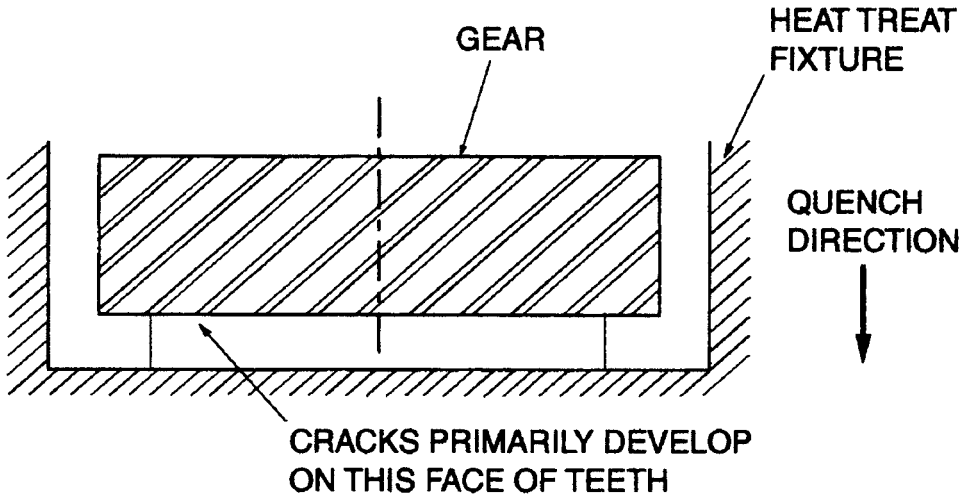


Fig. 5.44 Gear quenched in flat position

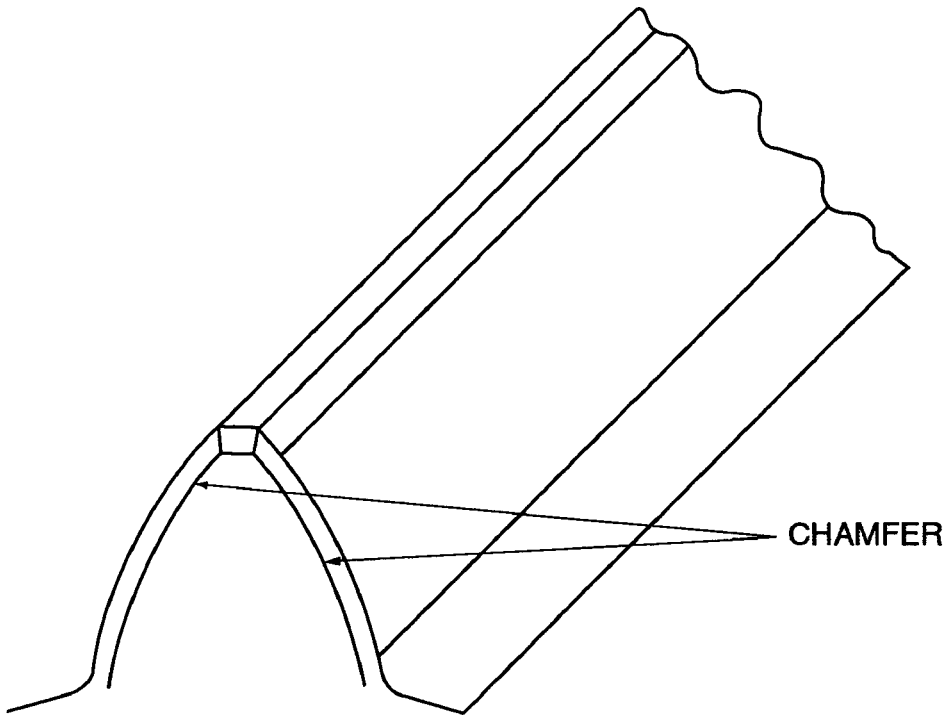
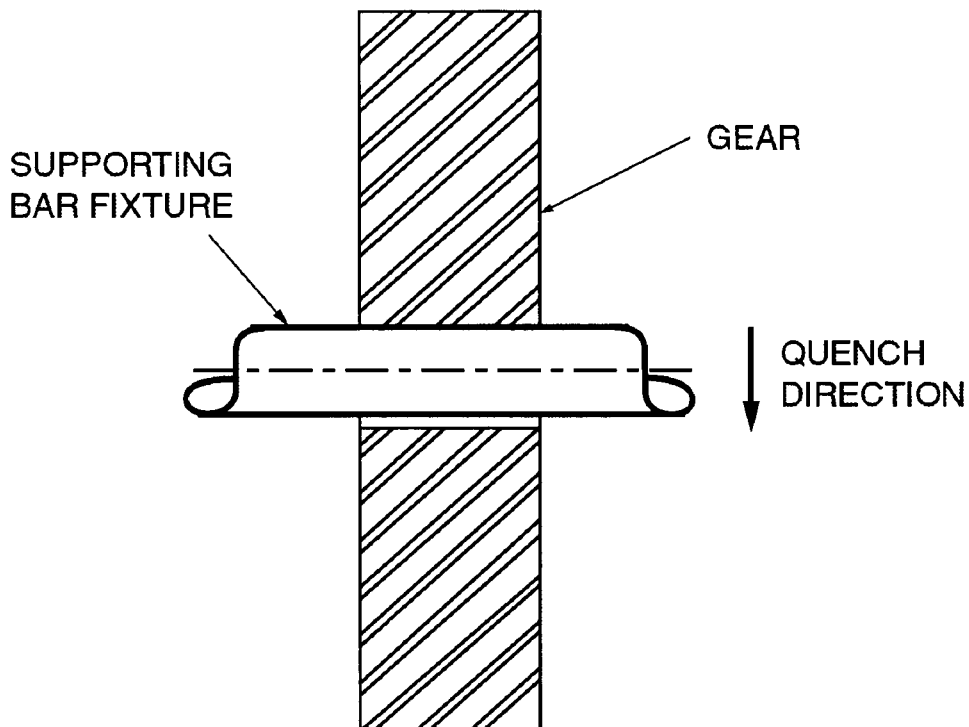


Fig. 5.45 Helical tooth with chamfer on tooth edge

Also, quenching of gears hanging from fixturing rods (Fig. 5.46) helps to reduce cracks at tooth edges. Certainly, this method of quenching is limited to smaller gears with low mass; large gears with heavy mass are not suitable because of higher distortion (PD runout). Cracks of this nature are not common with spur gears because spur gear tooth edges do not form any acute angles.

## Grinding Stock Allowance on Tooth Flanks to Compensate for Distortion

Gears that do not meet the quality requirements after heat treatment are usually ground, for which additional stock is provided on tooth flank. For a ground root, stock is also needed on the root. Grind stock is determined on the basis of cleaning of all the surfaces of teeth considering distortion and growth of gears after carburizing and hardening. The grind stock allowance on gear teeth should not de-emphasize the control required for minimum distortion. In fact, the control is just as necessary for gears that will be ground as it is important for gears that are not ground after heat treat. The reason is that if the distortion is high and corrected by grinding, it may result in uneven case depth or sometimes no case at all on some



**Fig. 5.46** Gear quenched hanging from bar

teeth. Furthermore, the addition of extra stock increases grinding time and cost. So, for good quality gears at optimum cost, the distortion during heat treat needs to be controlled. Distortion control will not only allow minimum removal of stock during grinding but also ensures “sound” gears from the metallurgical viewpoint.

In a well-controlled carburizing and hardening process, distortions could be held to within one AGMA class below the pre-heat-treat quality for gears made of commonly used materials such as AISI 4320H and 8620H. Such a process allows the establishment of a minimum grind stock on a tooth surface and the maintenance of the minimum surface hardness required after grinding. This satisfies the design requirement for minimum gear pitting life in most applications. Unfortunately, the state-of-the-art carburizing and quenching technology is unable to assure low gear distortion consistently in a production mode of operation. Sometimes, distortions within the same batch of gears are found to vary widely. Hence, it is very likely to find some gears after heat treatment with distortion far more than others. Grinding of such gears for minimum stock removal necessitates inspection of every gear in a batch for distortion severity. This increases the cost of gears. Furthermore, tooth surface hardness and effective case depth may not be acceptable after grinding.

Besides grinding, surface hardness reduction of carburized and hardened teeth is also influenced by the slope of hardness versus case depth gradient of gear steel. Each carburizing grade steel has its own unique slope and is primarily controlled by its alloying elements. The steeper the slope is, the greater the hardness reduction on tooth surface after grinding will be. In addition, grinding machine setup plays an important role in the equal amount of stock removal from each flank of the gear teeth and its associated hardness reduction.

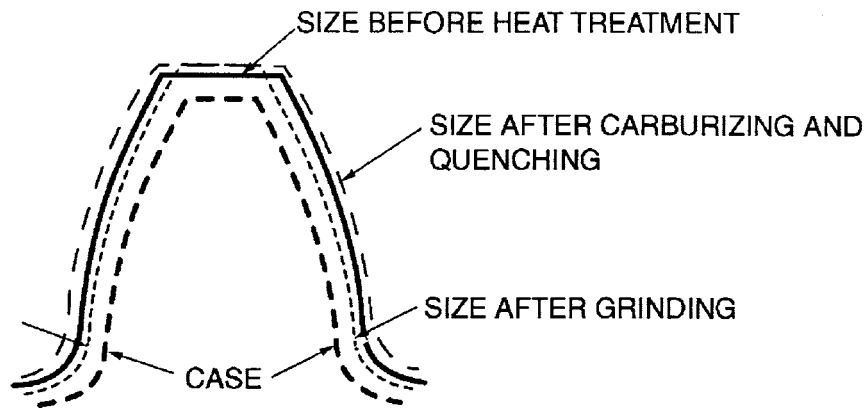
To establish an ideal grind stock, detailed distortion characteristics and growth data of gears are beneficial. For gears without any preproduction or historical data on heat treat distortion, general knowledge on heat treat response of the gear material helps to establish effective grind stock.

### ***Grinding of Distorted Gears***

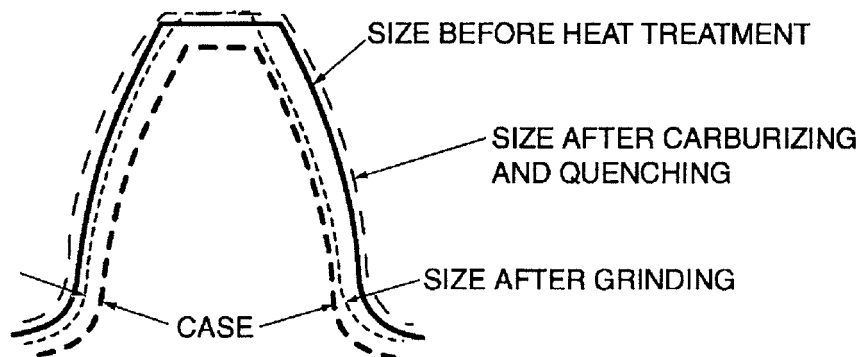
With the grind stock so determined either by a preproduction investigation or from data of similar gears, grinding of carburized and hardened gears is performed by properly positioning the grinding wheel in the tooth space. In modern gear grinding machines with advanced measurement systems, a probe measures the helix (lead) deviation on a predetermined number of right and left flanks of teeth at different locations that include teeth at maximum PD runout. The measured values not only contain the effect of all helix deviations and PD runouts, but also the effect of profile and cumulative pitch variations. The computer in the machine control calculates the optimum angular position of the gear before grinding starts. This method ensures that the grinding wheel will be positioned at the

center between two flanks, allowing equal stock removal from each flank starting with teeth at the maximum PD runout. The method works well as long as the distortions are comparatively small and their variations are distributed within a narrow band—one AGMA class below the pre-heat-treat quality.

For gears made of high-alloy steels such as AISI 9310 and AISI 8620 that exhibit uncontrolled distortion after carburizing and hardening, the selection of an effective grind stock is quite difficult. Tests carried out show gears made of these materials have larger variations of PD runouts and spacing of teeth. Furthermore, the distortion seems to vary in a random manner. Hence, considerable difficulty is experienced for equal stock removal from all the flanks of distorted teeth even with modern grinding machines. This leads to more-than-planned stock removal from some teeth flanks during grinding as illustrated in Fig. 5.47.



(a)



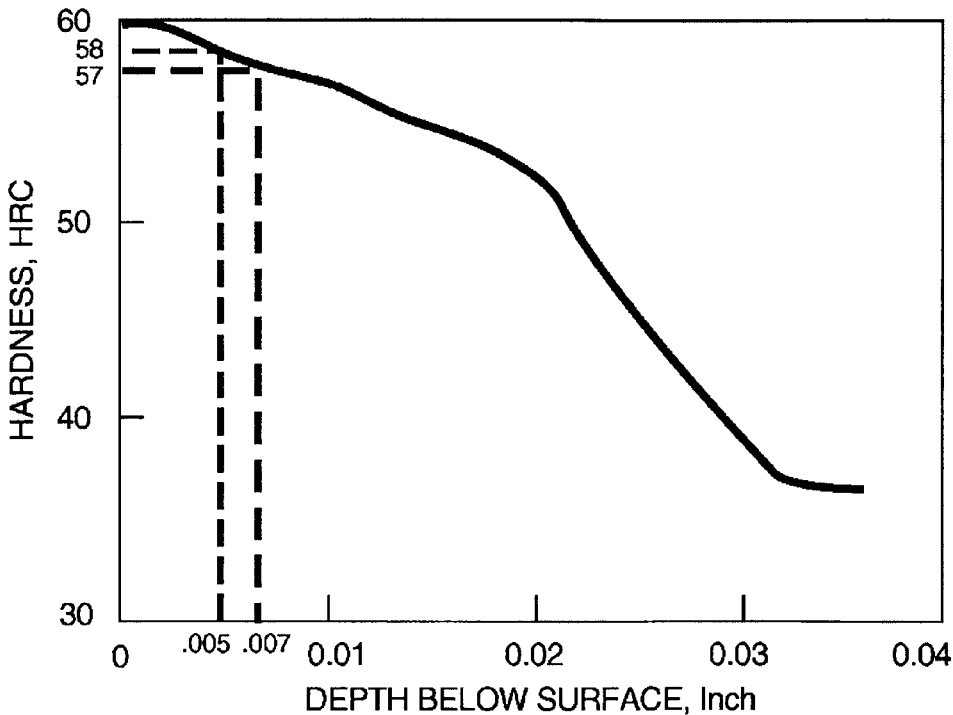
(b)

**Fig. 5.47** Schematic of materials ground from a carburized and hardened gear tooth. (a) Tooth with no distortion; equal stock removal from both flanks. (b) Tooth with distortion; more stock removal from one flank.

### Actual Stock Removal and Tooth Surface Hardness

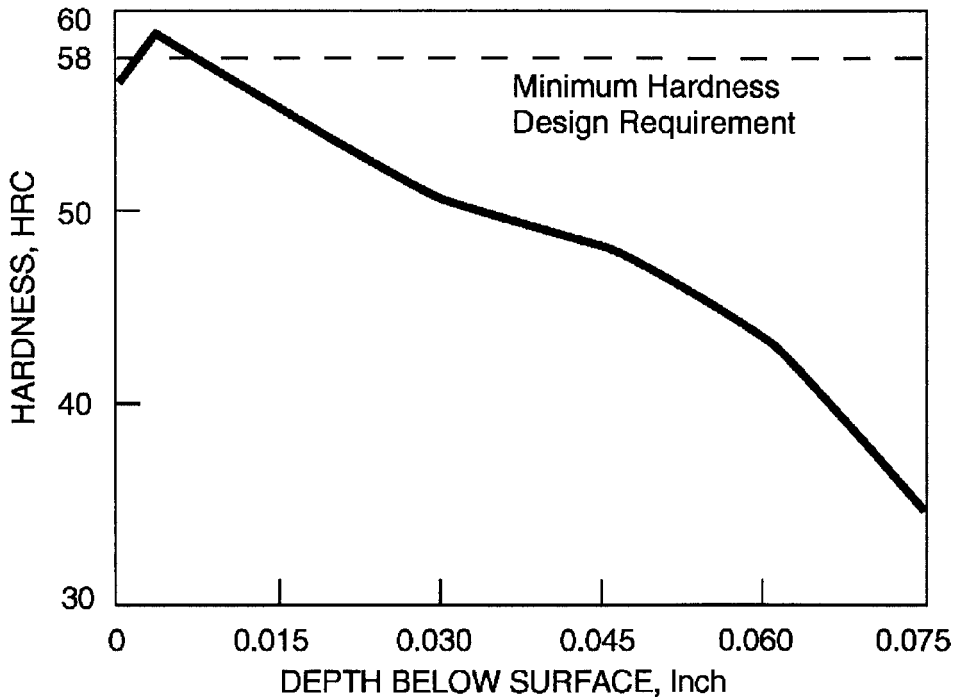
The more stock that is removed from the surface of a carburized and hardened tooth, the lower the tooth surface hardness will be. The degree of hardness reduction is dependent also on the slope of the hardness gradient of the tooth. Figures 5.48 and 5.49 illustrate hardness gradients of two low-alloy steels, the first one for 17CrNiMo6 and the other for AISI 8620H after carburizing and hardening. In comparison with 17CrNiMo6, the hardness gradient of 8620H exhibits a lower hardness at the tooth surface followed by a gradual increase in hardness with the maximum at a depth of 0.05 to 0.08 mm (0.002–0.003 in.) below the surface. This is believed to be due to higher than normal percentage (about 20%) of retained austenite at the surface of these gears after quenching. On the other hand, the percentage of retained austenite after cold treatment is much better controlled in most of the high-alloy steels. Consequently, these materials do not exhibit the characteristic of some low-alloy steels. This is depicted in Fig. 5.50 for AISI 9310H.

It is clear from the hardness gradients of various alloy steels that stock removal over 0.13 mm (0.005 in.) (normally allowed for grinding) from the flanks of distorted carburized and hardened gear teeth may result in

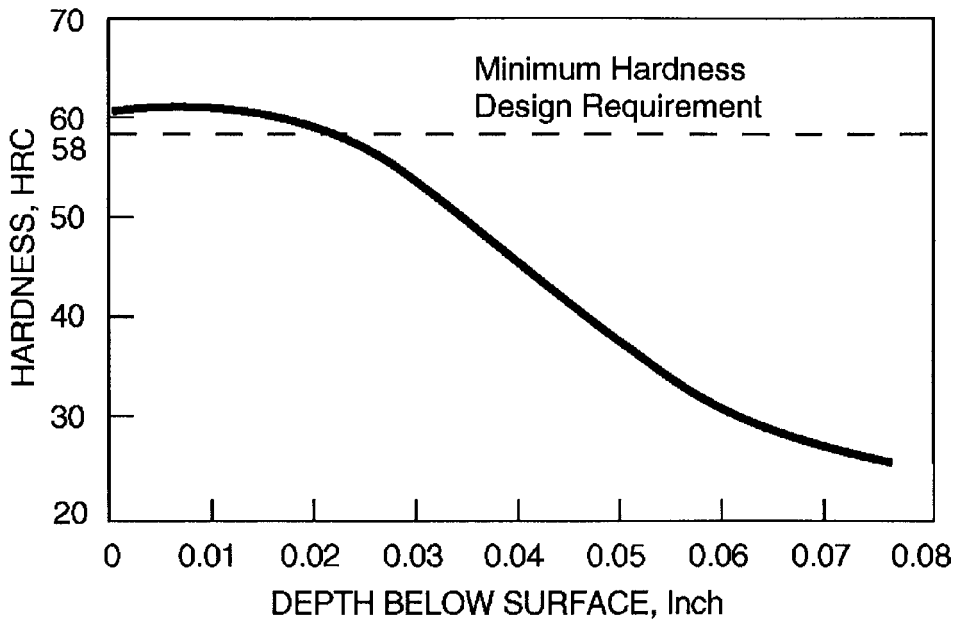


**Fig. 5.48** Hardness gradient of a carburized and hardened gear tooth. Material: 17CrNiMo6





**Fig. 5.49** Hardness gradient of a carburized and hardened gear tooth. Material: AISI 8620H



**Fig. 5.50** Hardness gradient of a carburized and hardened gear tooth. Material: AISI 9310H

lower than the minimum surface hardness required for the expected pitting life. Because of the steeper slope, a usual characteristic of low alloy steels (Fig. 5.49), the surface hardness reduction of gear teeth made of these materials is generally higher than those made of high-alloy steels. Again, distortion associated with low-alloy steel gears is comparatively less, and hence, these warrant smaller stock removal during grinding. Thus, the actual tooth surface hardness reduction after grinding is almost of the same magnitude for both low- and high-alloy steel gears. Sometimes, carburizing with boost-diffuse cycle produces a flatter hardness gradient. Because it is generally cost prohibitive, this type of carburizing is very seldom used. This allows the consideration of similar amounts of grind stock for all gear materials. Furthermore, grind stock required on each tooth flank for both low- and high-alloy steel gears with controlled heat treat distortion is found not to exceed an average of 0.13 mm (0.005 in.). Removal of stock to this depth does not seem to reduce tooth surface hardness below the minimum considered in design with carburized and hardened gears.

In a production-type carburizing and hardening operation, which is frequently associated with uncontrolled distortion, stock over 0.13 mm (0.005 in.) is very often removed from teeth located at maximum distortion. Such stock removal in some gears may result in surface hardness reduction as high as two points on the HRC scale, particularly for materials with a steep hardness gradient slope. As an example, in gears made of 17CrNiMo6, the hardness reduction for an additional 0.05 mm (0.002 in.) stock removal over planned 0.10 mm (0.005 in.) is approximately one point in HRC scale. This is a significant hardness reduction below the minimum considered during design. Lower surface hardness will definitely reduce pitting life. The new pitting life may be calculated from the equation derived from the pitting life versus contact stress relationship.

### ***New Pitting Life***

The equation for pitting life in terms of stress cycles ( $L_1$ ) of a gear at any power level can be estimated as:

$$L_1 = 10^7 \left( \frac{S_{ca_1}}{S_c} \right)^\alpha \quad (\text{Eq 9})$$

where  $S_{ca_1}$  is the allowable contact stress for the gear material at minimum hardness,  $S_c$  is the actual contact stress due to applied load, and  $\alpha$  is the slope of  $S$ - $N$  curve for gear durability = 17.62 (AGMA standard 2001-B88).

Similarly, the new pitting life ( $L_2$ ) for a lower allowable contact stress ( $S_{ca_2}$ ) due to reduced tooth surface hardness of the same gear and at the same power level is:

$$L_2 = 10^7 \left( \frac{S_{ca2}}{S_c} \right)^\alpha \quad (\text{Eq 10})$$

Equations 8 and 9 yield:

$$L_2 = L_1 \left( \frac{S_{ca2}}{S_{ca1}} \right)^\alpha \quad (\text{Eq 11})$$

From Eq 11, the pitting life of a gear can be calculated at any allowable contact stress that corresponds to a specific tooth hardness. For example, if due to additional stock removal (0.05 mm, or 0.002 in., over the allowed 0.10 mm, or 0.005 in.), the surface hardness of teeth reduces from 58 to 57 HRC (Fig. 5.48), the allowable contact stress ( $S_{ca2}$ ) for AGMA grade 1 material (Fig. 5.51) becomes:

$$S_{ca2} = 26,000 + 327 \text{ HB}$$

Brinell hardness number (HB) of tooth surface  $\approx 1475 \text{ MPa}$  (214 ksi)

The allowable contact stress ( $S_{ca1}$ ) at minimum hardness (58 HRC) per design is  $1500 \text{ MPa}$  (218 ksi). Using Eq 11 the new pitting life is:

$$L_2 = 0.72 L_1 \quad (\text{Eq 12})$$

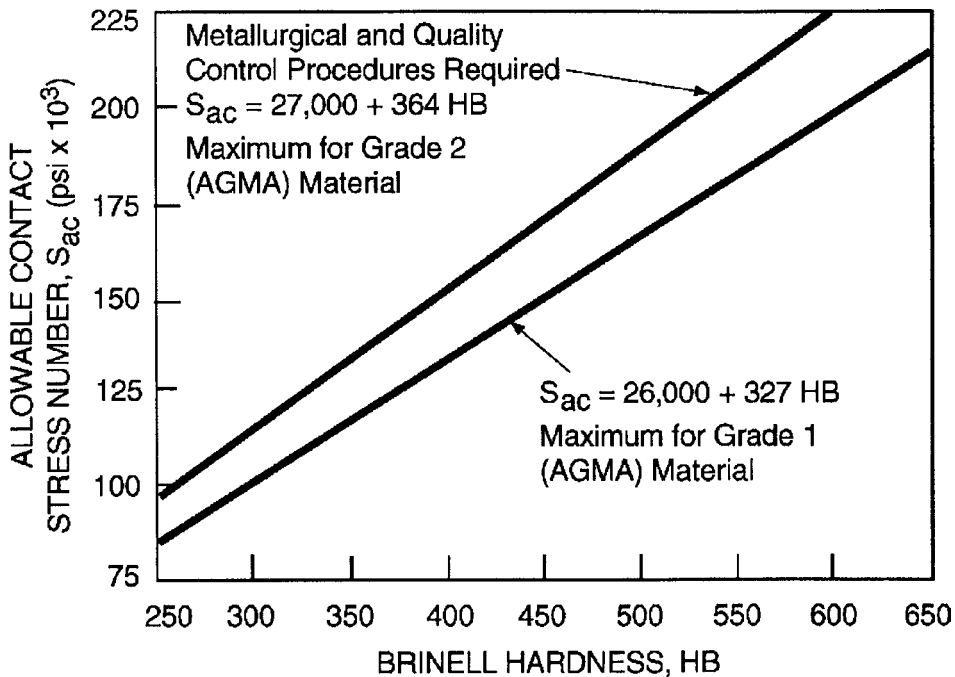


Fig. 5.51 Allowable contact stress number for carburized and hardened steel

This is a significant reduction of gear pitting life. Hence, for true pitting life of carburized, hardened, and ground gears, it is essential to consider heat treat distortion. Certainly, this necessitates the availability of heat treat distortion data for all newly designed gears—a difficult task to accomplish. One possible solution to the problem is to develop distortion-derating factors for various gear materials from known heat treat data and apply them to derate pitting life.

### ***Distortion Derating Factor***

The distortion derating factor (DDF) is defined as the ratio of actual pitting life to the required pitting life of gears. For realistic values of distortion derating factors, it requires comprehensive knowledge on composite distortion characteristics that include different gear materials, configuration and size of gears, gear diametral pitch and helix angle, heat treat process and equipment, and hardness gradient of each of these materials. Such a task is beyond the scope of this investigation. Nevertheless, it is endeavored to establish derating factors for some commonly used materials from available gear distortion characteristics as given in Table 5.14. These are based on an additional 0.05 mm (0.002 in.) stock removal above 0.10 mm (0.005 in.) normally allocated. Similar derating factors for other gear materials can be established from their composite gear distortion data.

Sometimes, to avoid the task of developing such distortion derating factors, an extra grind stock with additional case depth is suggested. The extra stock no doubt allows grinding of all the teeth to the required quality and geometry but does not help to maintain the surface hardness equally on all the teeth surfaces. Also, deeper case creates some serious heat treat problems for gears. First, it will increase carburizing cycle time and,

**Table 5.14 Distortion derating factors for true pitting life of carburized and ground gears**

Gear material	High or low alloy	Hardness versus case depth gradient		Distortion severity		
		Hardness drop less than half a point HRC for every 0.05 mm (0.002 in.). Stock overallocated (0.127 mm, or 0.005 in.)	Hardness drop more than half a point HRC for every 0.05 mm (0.002 in.). Stock overallocated (0.127 mm, or 0.005 in.)	Low (within 1 AGMA class below pre-heat-treat quality)	High (over 1 AGMA class below pre-heat-treat quality)	Distortion derating factor (DDF)
<b>Air melt</b>						
4320	High		X	X		0.80
8620H	Low		X		X	0.80
9310H	High	X			X	0.80
17CrNiMo6	Low		X		X	0.75
<b>Vacuum melt</b>						
4320	High		X	X		0.85
4330M	High	X			X	0.80
9310H	High	X		X		0.85
HP 9-4-30	High	X		X		0.90

hence, the cost. Secondly, it does not help to increase case hardness. Finally, a deeper case may cause some severe adverse effects such as:

- Through hardening of teeth, particularly for fine-pitch gears and gears with large pressure angle, above 20°
- Higher surface carbon—a potential source for inducing grind burn
- Additional grinding time—higher cost
- Larger step at the intersection of root radius and tooth profile for unground roots—higher stress concentration
- Increased percentage of retained austenite—lower surface hardness
- Increased level of undesirable carbide network in the case microstructure—mechanical properties of teeth may be affected

Considering all of these potential problems, a deeper case than what is needed is not recommended.

### ***Side Effects of Grinding Carburized and Hardened Gears***

Carburized and hardened gears are generally ground to improve distorted tooth geometry caused by heat treatment. To maintain the required case depth and tooth surface hardness after grinding, a certain amount of grind stock is provided to pre-heat treat tooth flanks, and the carburizing process is adjusted for case depth that includes grind stock. Besides improving the tooth geometry and maintaining an acceptable case depth and surface hardness, grinding has a profound effect on the tooth surface integrity such as grind burn and removal of residual surface compressive stress. Both grind burn on tooth surface and surface compressive stress reduction detrimentally affect the fatigue life of ground carburized and hardened gears. In this section, some discussion on the causes of and remedy for grind burn is presented. Also, a discussion on post-grinding process such as shot peening that reintroduces some of the lost compressive stress is included.

**Gear Grind Burns.** Gears and, as a matter of fact, any surface that is carburized, hardened, and subsequently ground, are subjected to retempering of localized areas popularly known as grind burn. The reasons for such burns on ground surface are generally attributed to improper carburizing and grinding operation. A large number of researchers have endeavored to identify the causes of the grind burn phenomenon, but none of them has come up with any useful solution to the problem. Nevertheless, the results of all these investigations indicate that a large number of carburizing process and grinding parameters influence grind burn. Carburizing factors that cause grind burn are:

- High surface carbon—0.9% and above
- High surface hardness—61 HRC and higher
- High retained austenite—above 20%

Grinding parameters that can contribute to grind burn are:

- High stock removal rate during grinding
- Sudden increase in stock removal from a tooth surface due to nonuniform heat treat distortion
- Too fine grit of abrasives on vitrified grinding wheel
- High grinding wheel hardness
- Unbalance in grinding wheel
- Infrequent dressing of grinding wheel resulting in glazing of wheel
- Improper type of coolant
- Inadequate flow rate and direction of coolant flow
- Presence of grind sludge in coolant due to malfunction of gear grinding machine coolant filters
- High coolant temperature
- Unstable machine

Any one or a combination of these factors can contribute to grind burn on a gear tooth surface that is ground, possibly by wet grinding that uses vitrified aluminum oxide wheel and cutting fluid. Gears are less vulnerable to such defect when ground in machines that operate dry. Unfortunately, such dry grinding machines are no longer used due to their long grind cycle time. Wet grinding machines recently developed for cubic boron nitride (CBN) wheels are found to be quite effective in ensuring grind-burn-free gear teeth. In any case, improperly carburized gears ground by uncontrolled grinding process can result in grind burn on tooth surfaces.

Grind burn lowers surface hardness on the burnt areas usually in the range of 2 to 3 points on the HRC scale. A burnt tooth, particularly at the point of maximum contact stress, lowers the contact fatigue life of the gear. Furthermore, a burnt tooth surface is frequently accompanied by microcracks. Although these cracks are very minute, they still can affect the fatigue life of a gear subjected to high cyclic load or that operating near a resonant condition. To ensure grind-burn free teeth, it is thus essential to inspect gears after grinding.

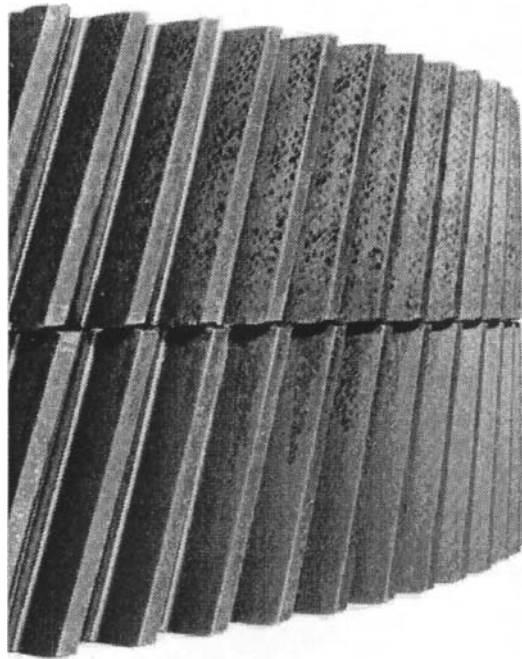
There are two different methods available in the gear industry to inspect gear burns—one is destructive and the other nondestructive. The destructive method provides a positive identification of burnt surfaces and is based on the microhardness reading of the surface below the burnt area. Such a method is not quite practical, whereas a properly controlled nondestructive method currently available can provide sufficient evidence of grind burn. The most common one is the nital, or temper etch, method.

*Gear Grind Burn Identification.* A good deal of controversy exists over the accuracy of the temper etch method results. Generally, nital etch inspectors are specially trained to distinguish between burnt and regular tooth surfaces, but sometimes fail. This happened in one gear manufac-

turing company with which the author was associated. At one point during normal manufacturing, this company was experiencing continual rejection of carburized and ground gears due to grind burns identified with nital etch. Even after implementing all necessary controls during carburizing and subsequent grinding, the problem of grind burn showed up from time to time. An external metallurgical inspection company was then employed to investigate whether the gears were definitely burnt or not. Figure 5.52 shows photographs of two such apparently burnt and rejected gears after nital etch. The gears were made of AISI 8625H, carburized and hardened, and the teeth ground on a Reishauer gear grinder, a wet grinding machine. Being unable to draw a definite conclusion, the company employed destructive microscopic examination of sections taken at the burnt areas. Surprisingly, the results did not reveal any rehardening or retempering of these areas at  $1000\times$  magnification. It was then concluded that the visible burn indications after nital etching were caused by differential skin etch reflection. A subsequent successful full-load test of the gears confirmed this conclusion. This is why each gear manufacturing company needs to develop its own criteria of acceptance and rejection of grind burns.

**Inspection and Limited Acceptance Criteria of Grind Burns.**

Because it is extremely difficult to grind gears except by CBN grinders without any grind burn in a production type environment, a discussion on



**Fig. 5.52** Experimental gears after nital etch for surface damage. Grinding patterns were observed after surface nital etch on both gears. Microscopic examination of sections removed from the gears did not reveal microstructural changes in the case hardened matrix in either gear.

inspection and its limited acceptance is considered helpful to establish optimum carburizing and heat treat conditions.

Gears shall be inspected visually for evidence of grind burns following the etching procedure under a light source of 200 footcandles (ftc) minimum at the surface being inspected. Surfaces not burnt will be uniformly gray to light brown in color, depending on the alloy used. Surfaces burnt will appear dark gray to black in color. These could be either overtempered or rehardened areas. Overtempered (burnt) area is due to localized overheating during grinding and will appear dark to black in color. This results in a lower surface hardness. A rehardened (burnt) area is due to transformation of retained austenite to untempered martensite and will appear as a white or light gray spot surrounded by black overheated area. Reharden areas are usually associated with grind cracks.

The hardness of overtempered areas may be measured with a Rockwell superficial hardness tester using the 15 N scale in accordance with ASTM E 18. For comparison, similar readings may be taken on adjacent areas of grind burn.

*Acceptance Criteria.* Basically, there shall be no rehardened and overtempered areas on any ground teeth of fracture-critical gears. Limited overtempering may be acceptable on non-fracture-critical gears. A number of aircraft and non-aircraft industries have been consulted to develop the acceptance or rejection criteria for grind burn. Refer to Fig. 5.53 for nomenclature of a gear tooth.

Overtempering of the active profile of a gear tooth is not acceptable. Limited overtempering below the form diameter and above the tooth root fillet area (transition zone) may be acceptable if the total burnt area does not extend more than the area designated in Fig. 5.54. Overtempering is also acceptable on the end faces of teeth as long as it complies with the figure and applies to gears that might experience tip and edge loading. Figure 5.55 shows acceptable overtempering of the active profile of gear tooth near the edges. This is applicable to gears that do not experience edge loading even with misalignment between meshing teeth designed with proper crowning on tooth lead. Figure 5.56 depicts acceptable overtempering of the active profile near the edges and the tip of a gear tooth that does not experience either edge or tip loading.

## Shot Peening of Carburized and Hardened Gears

---

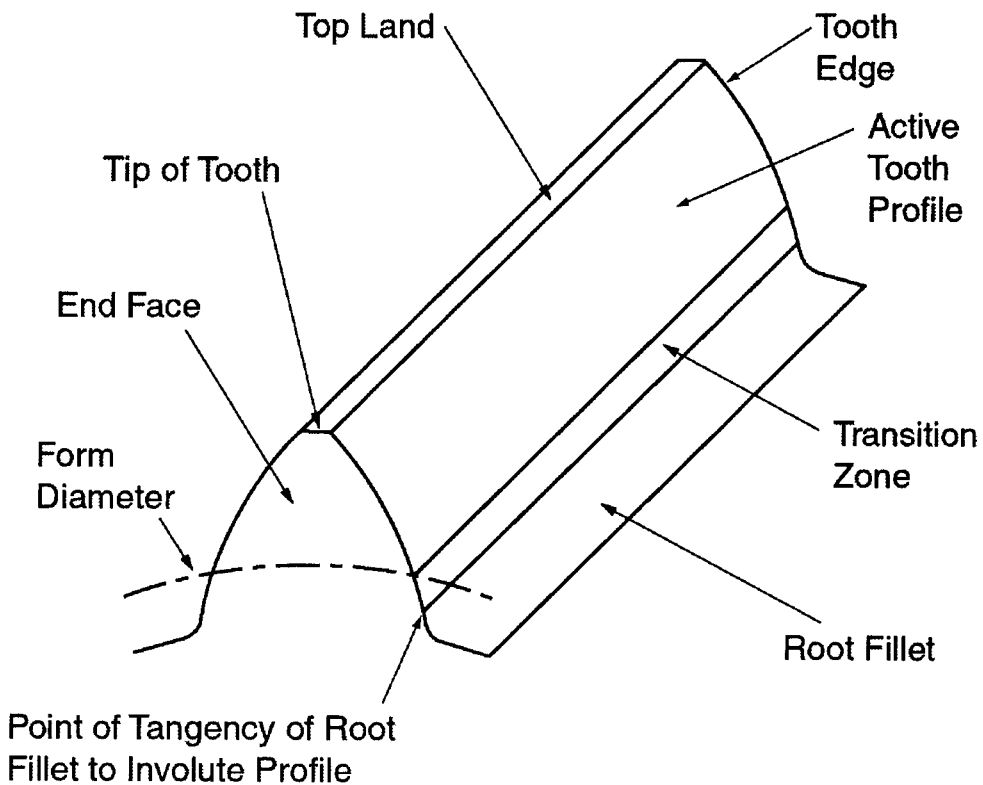
In general, all carburized and hardened gears are either ground or honed. Gears with low distortion and low tooth quality requirement (AGMA class 9 or below) are normally honed. Conversely, gears with high distortion and high quality requirement (AGMA class 10 and above) are finish ground. Honing does not remove much stock—less than 0.01 (0.0005 in.) from a tooth surface. Thus, the hardness profile of tooth



remains approximately the same as obtained after carburizing and hardening. This keeps the compressive stress induced at the surface during carburizing intact. However, in ground gears this is not the case. Very often stock up to 0.13 mm (0.005 in.) stock or more is removed from a tooth surface that reduces the surface hardness as well as removes the induced compressive stress during carburizing. These dual effects lower pitting life of ground gears significantly.

To improve pitting life of ground gears, tooth surfaces (ground and unground part of the profile) as indicated in Fig. 5.57 are frequently shot peened after grinding to induce compressive residual stress at and below the surface. Thus, some knowledge of proper shot peening process that enhances the performance of carburized, hardened, and ground gears is considered beneficial.

Shot peening is basically a mechanical process for improving fatigue strength of a part and has been in practice for a long time. In medieval times, a knight's armor was cold worked to final shape and hardness by hammering with a round-edged hammer. The repeated hammering improved armor fatigue life. Today, hammering is replaced with shot

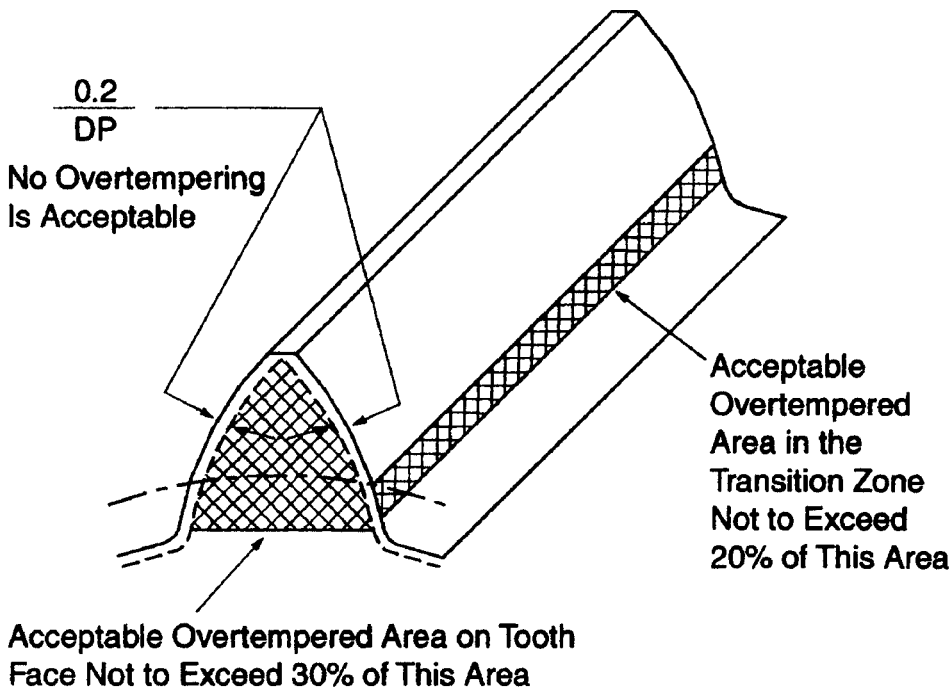


**Fig. 5.53** Gear tooth nomenclature

peening, which consists of bombarding a surface with small spherical metallic balls at a high velocity. Each shot acts as a tiny peenhammer, making a small dent on the surface of metal and stretching the surface radially as it hits (Fig. 5.58). The impact of the shot causes a plastic flow of the surface fibers extending to a depth depending upon degree of impact of the shot and the physical properties of the surface being peened. The effect of shot peening is similar to cold working to distinguish it from metal flow at high temperatures. Furthermore, it does not affect case thickness or case properties of ground, carburized, and hardened gears.

Experimental work indicates the surface compressive stress after shot peening to be several times greater than the tensile stress in the interior of the section. Figure 5.59 shows a typical compressive stress profile developed on a gear tooth fillet that was shot peened after grinding.

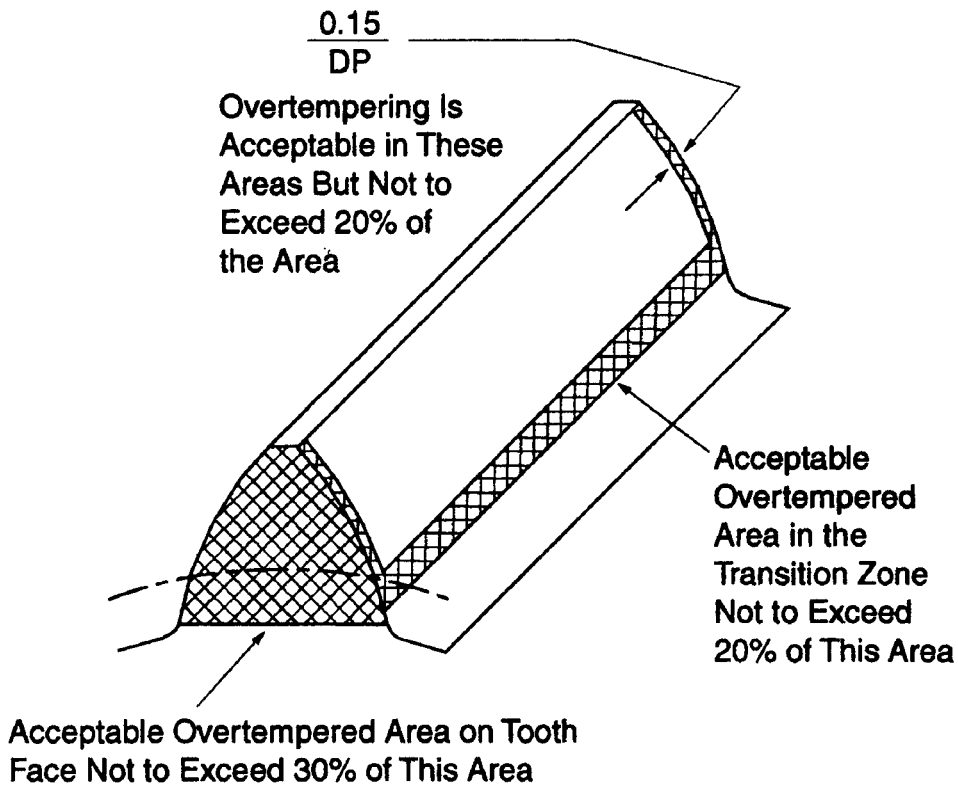
Because all fatigue failures originate with cracks, compressive stresses induced on the gear tooth fillet surface provide considerable increase in gear fatigue life because cracks do not initiate or propagate in compressively stressed zones. This makes the bending fatigue life of properly shot-peened gears 1.5 to 2 times the life of unpeened gears as illustrated in Fig. 5.60. In some gears, shot peening is limited to root fillet alone, which makes it necessary to mask the rest of the gear tooth surface. Also,



**Fig. 5.54** Overtempering of gear tooth

such masking needs to be removed after peening that increases the cost of gear. Active tooth profiles used to be masked because it was believed shot peening deteriorated the tooth profile and surface, and thereby reduced the pitting life of the gear. Thus, gear engineers were not very enthusiastic about shot peening the entire tooth surface until recent research showed a considerable increase in pitting fatigue life of gears besides increased bending fatigue life when the active tooth profile also was peened. Such an improvement was achieved with a precisely controlled and monitored shot peening process. Now that shot peening is widely accepted to enhance gear life, the following are some of the guidelines for such a process.

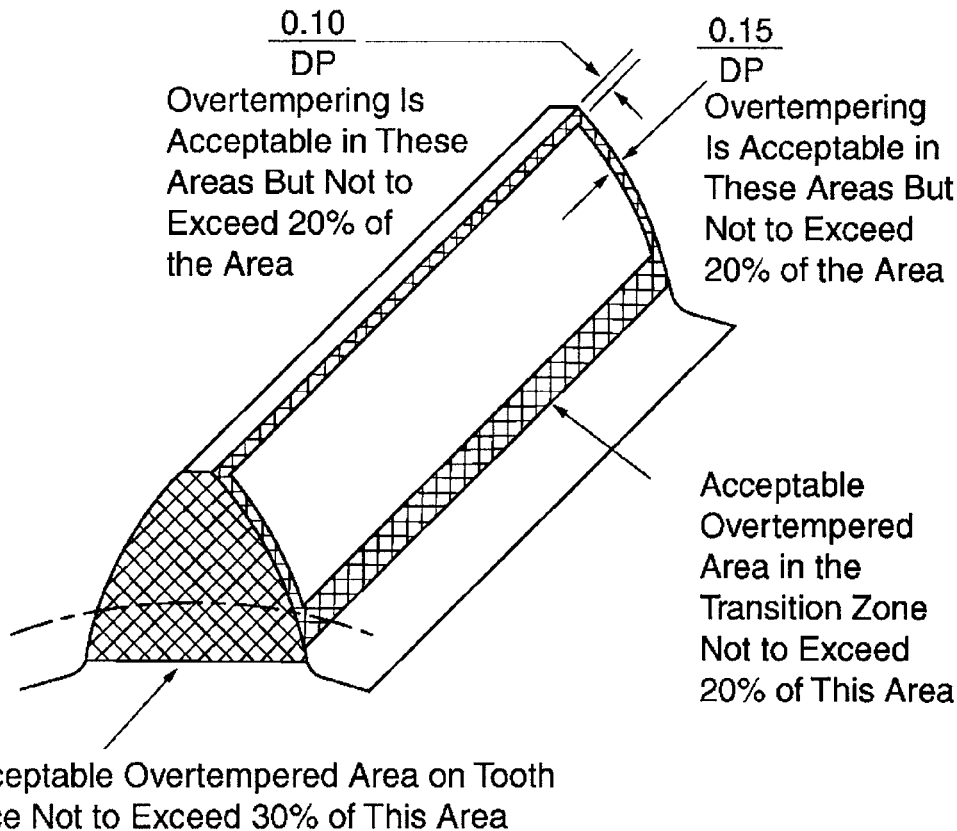
**Type of Shot.** From the standpoint of economy of operation, steel shots are preferred over cast iron shots. For good peening, the shots must be hard in the range of C 42 to 50 HRC. Also, the shots need to be approximately round and uniformly sized at all times. As the shots break up, broken particles must be removed because sharp corners of broken or



**Fig. 5.55** Acceptable overtempering of active profile gear tooth near the edges

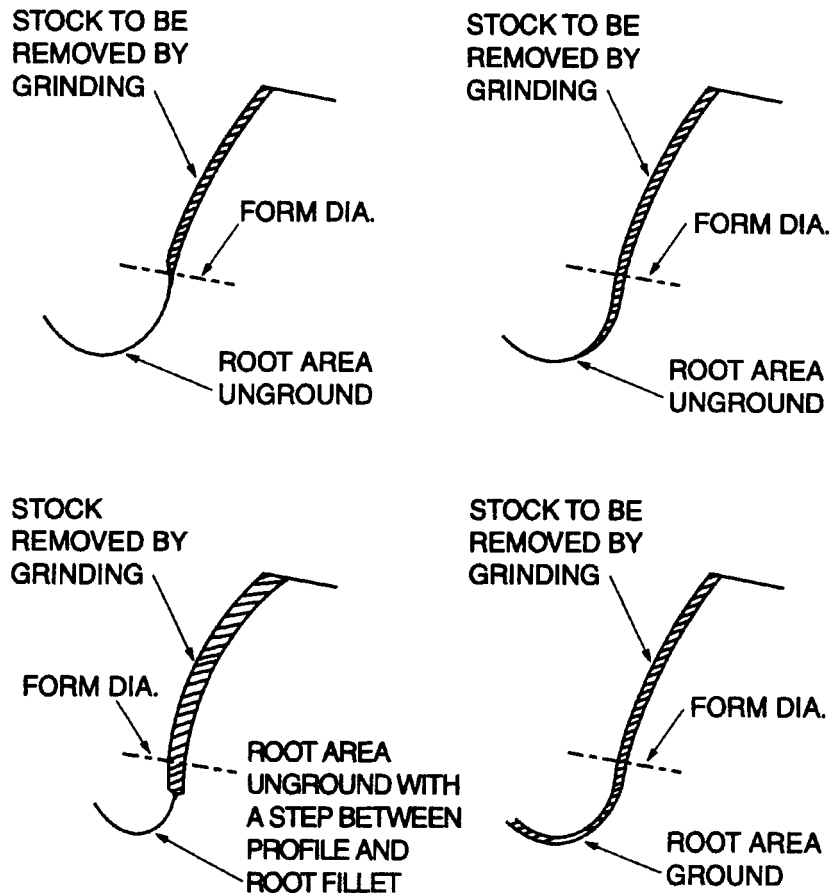
uneven shot may produce harmful effects that lead to a lower fatigue life. Shot supply is to be monitored in the machine so that no more than 20% of the particles, by weight, pass through the screen size specified for the shots, which come in different sizes such as S230, S170 (number indicates the diameter of the shot: 0.023 in. for S230, and 0.017 in. for S170).

**Shot Size.** The basic rule for shot size is that its diameter should not be greater than one-half as large as the root fillet radius of gear tooth. Shot size also should be correlated to the intensity of peening required, but without violating this rule. For low intensity, small shot should be specified and for high intensity, large shot. However, the peening machine, nozzles, air pressure, and volume also dictate, to a large extent, the most appropriate shot size. In general, the smallest shot size that will produce the required intensity should be used. The smaller the shot is, the faster the coverage rate and the shorter the peening time will be.



**Fig. 5.56** Acceptable overtempering of active profile gear tooth near the edges and tip of a gear tooth that does not experience either edge or tip loading

**Intensity.** The depth of the compressive layer on tooth surface is proportional to the shot intensity used. Thus, calibration of the impact energy from shot peening is essential for a controlled process. The energy of the shot stream is found to be a function of the shot size, material, hardness, velocity, and impingement angle. Specifying all of these variables would be difficult and impractical. The job is simplified by a method of measuring and duplicating shot-peening intensity on standard steel control strips developed many years ago by J.O. Almen of General Motors Research Laboratories. In his method, a flat strip of cold-rolled spring steel with a hardness of 44 to 50 HRC is clamped to a solid steel block and exposed to a shot stream for a given period of time. Upon removal from the block, the residual compressive stress and surface plastic deformation produced by the peening impacts will cause the strip

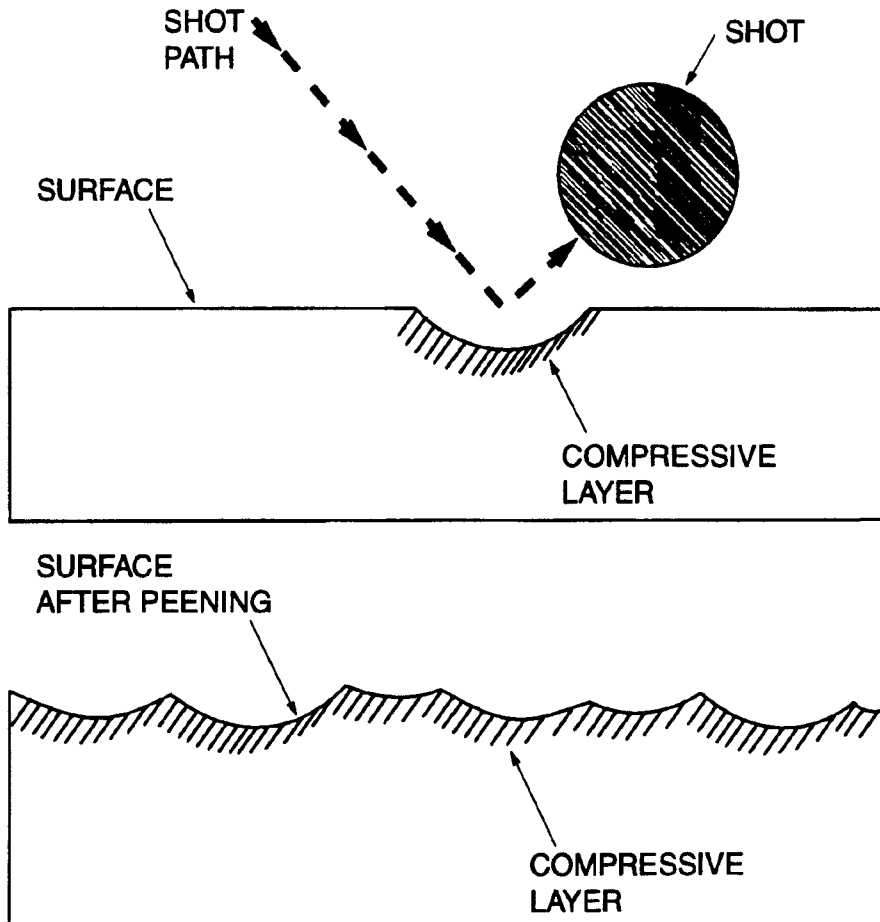


**Fig. 5.57** Different configuration of tooth surfaces after grinding

to curve, concave on the peened surface. The height of this curvature serves as a measure of peening intensity.

There are three standard strips used to provide for different ranges of intensities: "A" strip (1.3 mm, or 0.051 in. thick), "C" strip (2.4 mm, or 0.094 in., thick), and "N" strip (0.8 mm, or 0.031 in., thick). The approximate relationship between the A, N, and C strips is:  $3N = A = 0.3C$ . The A strip is the one most commonly used. If the arc height of the A strip is less than 0.10 mm (0.004 in.), the N strip should be used. For A strip readings greater than 0.51 mm ( $> 0.020$  in.), the C strip should be used. A reading of 10 A intensity means 0.25 mm (0.010 in.) arc height on the A strip.

**Coverage.** Amount of coverage is an essential element of a peening operation. Full, or 100%, coverage is defined as the uniform and complete dimpling of tooth surface as determined visually by a magnifying glass or the peen scan process. Most carburized and hardened gears require 200 to 300% coverage. Peening of gears beyond this range will not produce



**Fig. 5.58** Principle of shot peening

much improvement. Saturation or full coverage is defined as that point when doubling the peening time results in a 10% or less increase in height of Almen strips.

**Angle of Shot Impingement.** In case the shots do not impinge the surfaces at a proper angle, sometimes tensile stresses are introduced on tooth surfaces. For fine DP (above 20 DP) gears, the angle is particularly important to ensure that the shots impinge the root fillet as well as the profile of the tooth.

Whenever possible, microprocessor-controlled shot peening is recommended for predictability, reproducibility, and verifiability of the process. This allows optimum level of each variable to be maintained, thereby improving the quality of shot peening.

**Residual Stress.** Compressive stress at and below the surface after shot peening of gears is shown in Fig. 5.61. The figure definitely shows the benefits of shot peening carburized, hardened, and ground gears.

Some guidelines of shot peening parameters for different DP carburized and hardened gears are given in Table 5.15.

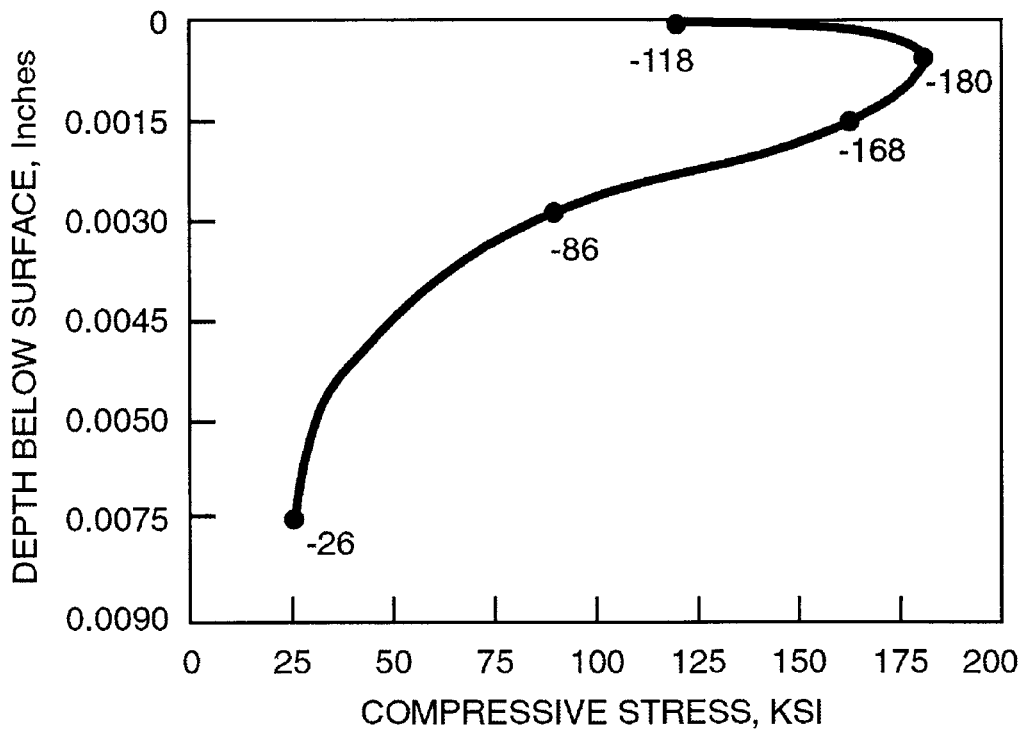
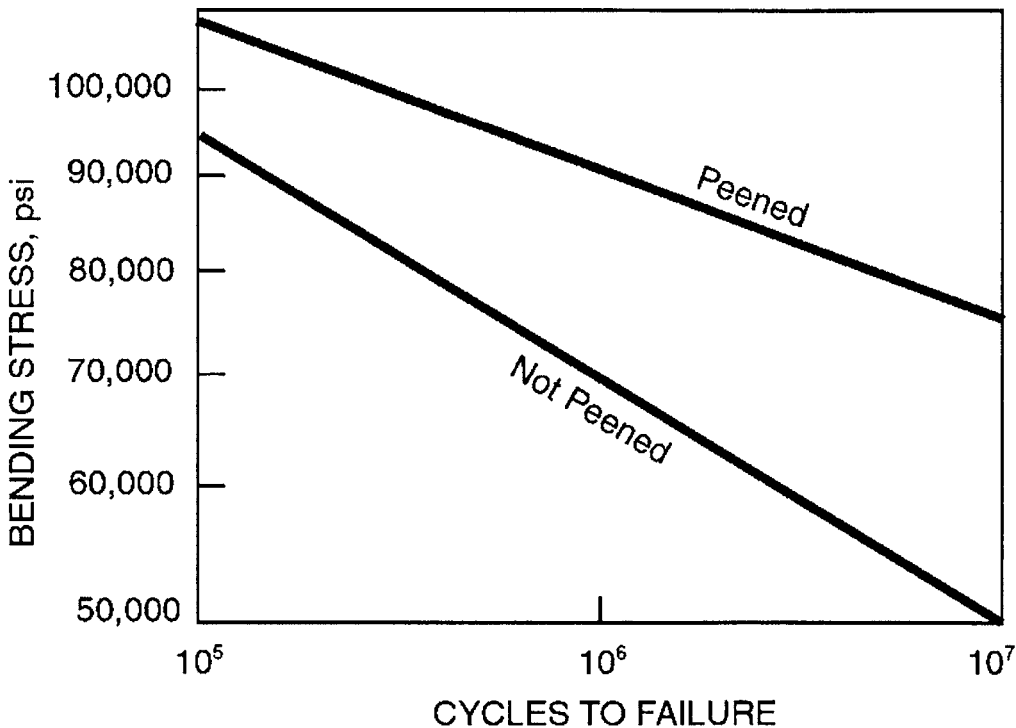


Fig. 5.59 Stress profile of carburized gear tooth root ground and shot peened

**Tooth Surface Profile.** A typical gear tooth surface profile after shot peening is shown in Fig. 5.62. It clearly shows there is not much deterioration of the surface after shot peening.

**Shot Peening Specification.** In specifying shot peening requirements on a gear, the following parameters identified on a drawing help to minimize confusion:

- Area to be shot peened
- Areas to be masked
- Optional areas that can be shot peened or masked
- Shot size, hardness, and material
- Intensity
- Coverage
- Equipment: microprocessor controlled or standard



**Fig. 5.60** Fatigue strength chart of carburized gears. Courtesy of Metal Improvement Company, Inc. (*Shot Peening Applications*)



Some typical shot peening parameters for carburized and hardened gears (AISI 9310 material) are:

Parameter	Value
Shot size	70
Shot type	Cast steel
Shot hardness	45 to 50 HRC
Intensity (height of Almen strip; type A)	0.178 to 0.229 mm (0.007 to 0.009 in.)
Coverage (profile and root)	200%

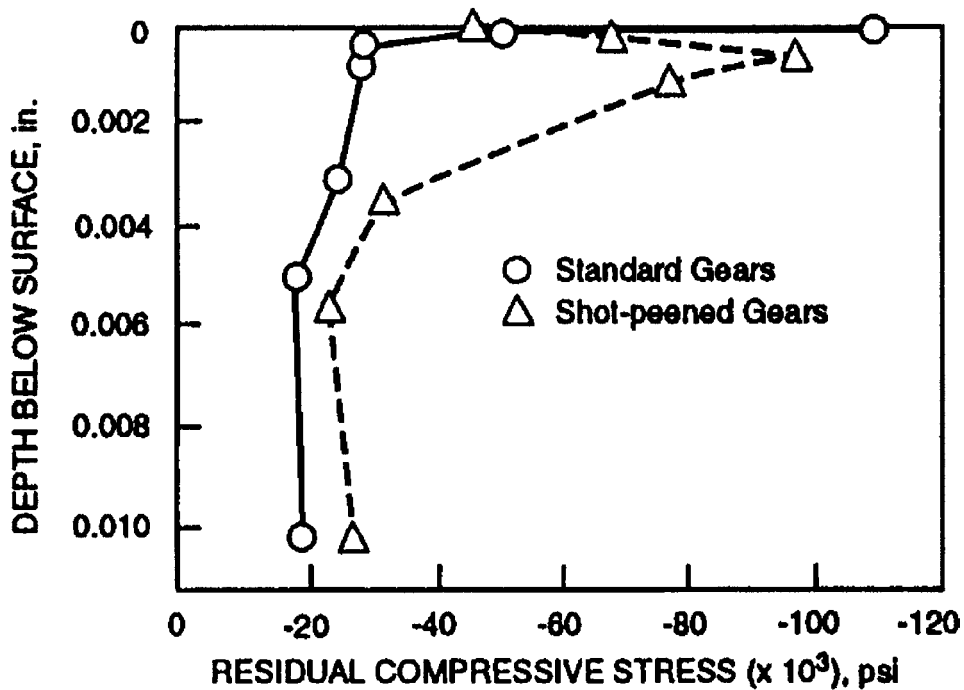
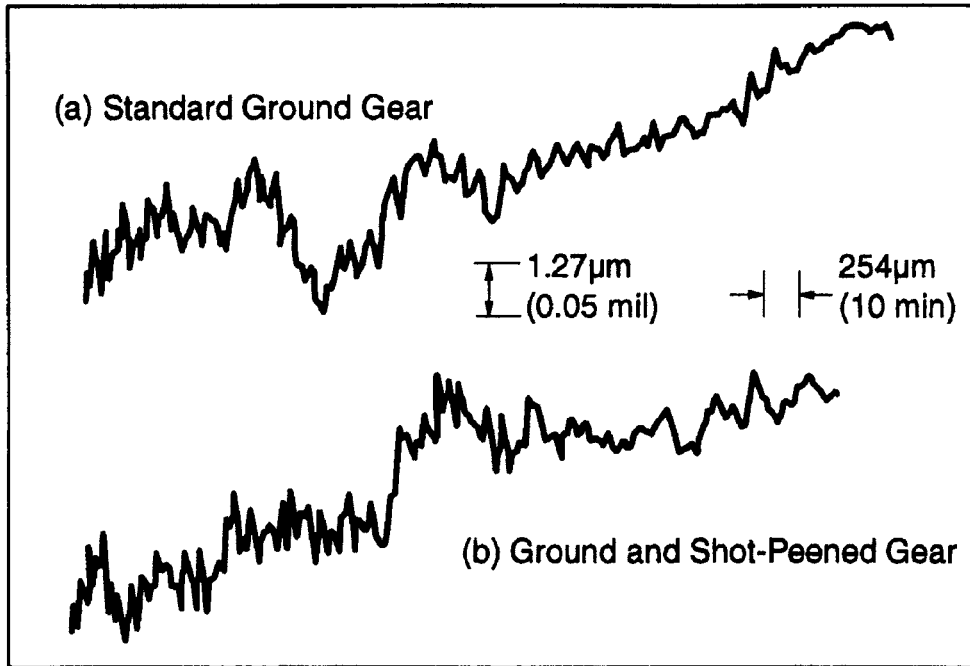


Fig. 5.61 Residual compressive stress below surface for standard and shot-peened gears

Table 5.15 Recommended shot peening parameters

Diametral pitch (DP)	Shot peening intensity(a)	Shot diam, mm (in. $\times 10^{-4}$ )	Shot type (HRC 42-50)	Coverage(b), %
20	0.006A	0.178 (70)	Cast steel	200
16	0.008A	0.178 (70)	Cast steel	200
10	0.010A	0.279 (110)	Cast steel	200
7	0.014A	0.432 (170)	Cast steel	200
5	0.018A	0.584 (230)	Cast steel	200
4	0.021A	0.711 (280)	Cast steel	200
3	0.007C	0.838 (330)	Cast steel	200
2	0.010C	1.168 (460)	Cast steel	200

(a) Almen strips: A,  $1.3 \pm 0.025$  mm ( $0.051 \pm 0.001$  in.); C,  $2.39 \pm 0.025$  mm ( $0.094 \pm 0.001$  in.). (b) 200% indicates a double shot-peening process.



**Fig. 5.62** Tooth surface finish of standard ground and shot-peened gears

## Heat Treat Characteristics of Two Commonly Used Gear Materials: AISI 4320 and 9310

These two materials are extensively used for gears in critical applications. The following information is considered helpful to select one over the other.

**Chemistry.** The chemical compositions, by weight percent; of AISI 4320 and 9310 steels are given in the following table:

Material (AISI steel)	C	Mn	Ni	Cr	Mo	Si	ASTM grain size
4320	0.17–0.22	0.45–0.65	1.65–2.0	0.40–0.60	0.20–0.30	0.20–0.35	6–8
9310	0.08–0.13	0.45–0.65	3.00–3.5	1.00–1.4	0.08–0.15	0.20–0.35	5–7

**Hardenability.** Experimental investigations show as-quenched hardness of 4320 (even at center) to be higher than 9310 up to 13 mm ( $\frac{1}{2}$  in.) round. This means 4320 is more suitable than 9310 for gears with tooth thickness up to 13 mm ( $\frac{1}{2}$  in.). Over 13 mm ( $\frac{1}{2}$  in.) size, 9310 has higher hardness. Thus, for tooth thickness over 13 mm ( $\frac{1}{2}$  in.), 9310 is preferred—core hardness of 34 to 38 HRC is achievable. Core hardness of 4320 generally lies between 30 and 35 HRC.

**Case Hardness.** Due to higher nickel content (which promotes retained austenite), it is sometimes difficult to attain high hardness levels (above 58 HRC) with 9310. Gears made of this material usually have to be cold treated after carburizing and quenching to attain hardness level of 60 HRC and above. Conversely, 4320 does not require any such freezing or cold treatment.

**Carburizing Cycle Time.** Time to develop a given case depth is less with 4320. This helps to reduce manufacturing cost of gears made of 4320.

**Distortion.** Historically, distortion with gears made of 4320 is found to be more controllable and predictable. This assures maintenance of surface hardness and case depth better with 4320 after grinding of teeth, if needed for high quality.

**General Comment.** Considering all the merits and demerits, 9310 is still considered a better gear material than 4320 for most critical applications because of a number of other important mechanical properties. Also, a vast field of data of successful applications is available for AISI 9310 that gives gear engineers a high level of confidence in the material.

## Carburizing Cost

Tables 5.16(a) to (d) show how carburizing cost varies with case depth, tolerance, and any special features.

**Table 5.16(a) Case depth versus cost**

Case depth requirement, mm (in.)	Cost factor	Rejection, %	Scrap, %	Manufacturing difficulty index(a)
0.25 (0.010)	1.0	5	3	8
0.51 (0.020)	1.1	3	2	4
0.76 (0.030)	1.2	3	2	4
1.02 (0.040)	1.3	4	2	6
1.27 (0.050)	1.4	6	3	8
1.52 (0.060)	1.6	8	4	9
1.78 (0.070)	1.8	8	4	10

The control of carbon concentration and case depth is more difficult in long carburizing cycles. Also, very low case presents higher manufacturing difficulty as does excessive case. (a) Higher number indicates more difficulty.

**Table 5.16(b) Case depth tolerance versus cost**

Case depth tolerance(a), mm (in.)	Cost factor	Rejection, %	Scrap, %	Manufacturing difficulty index(b)
$\pm 0.05$ ( $\pm 0.002$ )	2.0	20	10	10
$\pm 0.08$ ( $\pm 0.003$ )	1.4	15	8	9
$\pm 0.10$ ( $\pm 0.004$ )	1.2	4	2	7
$\pm 0.13$ ( $\pm 0.005$ )	1.0	3	2	5
$\pm 0.18$ ( $\pm 0.007$ )	0.8	0	0	4
$\pm 0.25$ ( $\pm 0.010$ )	0.7	0	0	2

(a) Case depth tolerance must be greater than the carburizing process control capability to allow for various stock removal requirements. (b) Higher number indicates more difficulty.

**Table 5.16(c) Special features versus cost**

Carburizing features	Cost factor	Rejection, %	Scrap, %	Manufacturing index(a)
Single case	1.0	3	1.5	5
Dual case	2.5	25	12.0	10

(a) Higher number indicates more difficulty.

**Table 5.16(d) Surface coverage versus cost**

Surface coverage	Cost factor	Rejection, %	Scrap, %	Manufacturing index(a)
All over	1.0	4	2	5
Partial	3.5	4	2	10

The cost of masking and copper plating for selective carburizing is significant. (a) Higher number indicates more difficulty.

## Applications

A vast majority of gears used in industrial applications today are carburized and hardened. It is because the process offers the highest power density in a gearbox through optimum gear design. High surface hardness, high case strength, favorable compressive residual stress in the hardened case, and suitable core properties, based on appropriate grade of steel, result in the highest gear rating. Furthermore, carburized gears offer superior heat resistance compared with other case hardening processes. These gears are also capable of withstanding high shock load. In general, smaller gears are carburized. Nonetheless, gears up to a 2030 mm (80 in.) diameter have been successfully carburized.

Today, gas carburizing is extensively used to carburize gears because a great deal of improvement has been made in this technology since the days of pack or liquid carburizing. This is carried out mostly in air furnaces, although partial and full vacuum furnaces and fluidized-bed furnaces with improved controls also are used for high quality of carburized and hardened case.

The major disadvantage of carburizing and hardening is high heat treat distortion; although, recent advancements in carburizing furnace technology and equipment, press quenching, selection of proper steel, and control of manufacturing process have contributed greatly in controlling and minimizing this distortion. Low distortion helps to reduce gear finishing cost.

### Case History: Distortion Control of Carburized and Hardened Gears

A well-known gear manufacturing company was having a serious problem with distortion of its carburized gears. To be competitive, it was essential for the company to develop optimum manufacturing processes

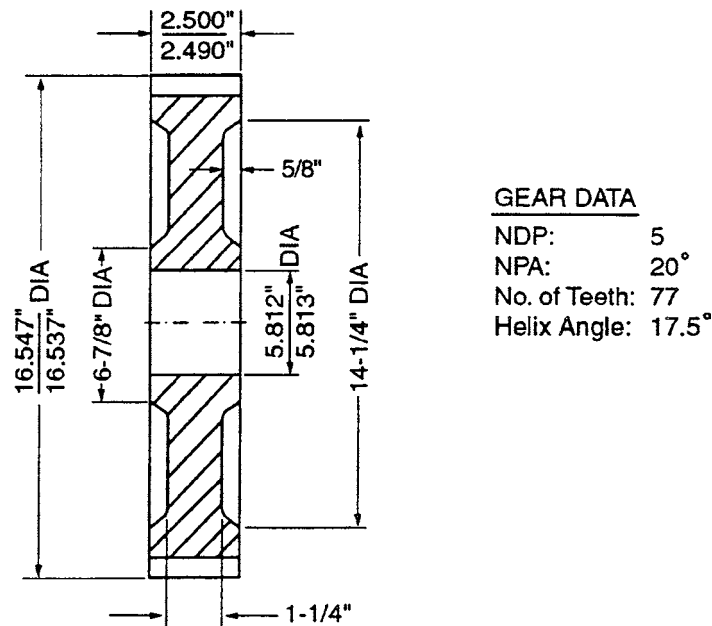
that would yield acceptable products at minimum cost. For this purpose, a heat treat process that would produce minimal distortion of the gears was essential.

A considerable amount of distortion was being experienced with gears made from AISI 8625 H (air-melted) forgings. The basic dimensions of a typical gear are shown in Fig. 5.63. The Jominy specification of material was J16. The gears were hobbed and shaved to AGMA class 10. After heat treatment, the geometry of gear teeth deteriorated to AGMA class 8. The requirement was AGMA class 9, and hence, gears were not acceptable. The gears required grinding to improve quality, adding cost, which was not acceptable. An experiment was then undertaken to reduce heat treat distortion. It was shown how an improved heat treat facility and process could improve the quality of gears by reducing distortion. A brief description of the heat treat facility is given here.

### ***New Heat Treat Facilities***

As discussed previously, proper carburizing and quenching are essential for sound metallurgical properties and minimum distortion of gear teeth. For this purpose, heat treat facilities using the state-of-the-art technology were acquired and installed. The highlights of the furnace construction, quench system, atmosphere generation, and controls follow.

**Furnace System.** The furnace used in the investigation was an in-out (batch)-type furnace. This type of furnace has better atmospheric sealing than a through furnace because its carburizing chamber is buffered from



**Fig. 5.63** Basic dimensions of the experimental gear

outside atmosphere by a vestibule chamber. The vestibule chamber opens to the outside. On the other hand, a through furnace has two doors—one of which opens directly to the outside atmosphere. Consequently, the in-out furnace provides more consistent control of the furnace atmosphere and takes far less recovery or conditioning time for the furnace atmosphere than does a through furnace.

**Quench System.** To minimize heat treat distortion, the furnace was equipped with a specially built quench tank that incorporates some uniquely designed baffles at the bottom to produce a directed laminar flow of oil up through the workload for rapid, uniform heat transfer from the gears to the circulating cooling oil. For optimum quenching, the system had two speeds—high and low. At the high position, an oil flow of 24,000 gpm was achieved and was used during the initial quench cycle followed automatically by 12,000 gpm of oil flow at the low position. The rapid flow rate was accomplished with four submerged impeller-type circulators, each rated at 6000 gpm. Furthermore, the holding capacity of the quench tank was 22,700 L (6000 gal), providing more than a gallon of quench oil to a pound of work load. The automated system also incorporated the use of a fast and hot quench oil. The temperature of this oil was kept at 120 °C (250 °F). The speed of the oil was 18 s. This fast and hot quench oil allowed the austenite to transform quickly with minimum thermal shock. To maintain the quench oil temperature within 14 °C (25 °F), an acceptable temperature variation for optimum quenching, some efficient liquid/air heat exchangers had to be installed.

**Nitrogen-Based Atmosphere.** The furnace was equipped with a nitrogen-methanol system for producing the desired furnace atmosphere instead of natural gas or propane as is used with conventional endothermic generators. Such a system provided reliable carbon control in the furnace atmosphere for improved heat treatment. The system could also quickly adjust the furnace atmosphere for composition and flow of the carburizing gas.

**Furnace Control System.** An integrated microprocessor unit that was capable of automatically controlling the various heat treat parameters such as furnace temperature, carbon potential of furnace atmosphere, oil flow, quench oil temperatures, and so on, which all contribute to optimizing the process, was installed. The system was also equipped to use preprogrammed processing modules for each individual gear or pinion. With such modules, a very accurate and repetitive control of the carburizing process was achieved.

## Tests

A gear (Fig. 5.63) was selected for trial runs. Before starting processing, forgings of this gear were separated by material heat code provided by the forging supplier and identified. Table 5.17 gives the heat code, chemical composition, and Jominy specification for the forging. Forgings of the

same heat code were then processed in a batch. To make sure that forgings were properly normalized, one forging of this gear was sectioned and inspected for material microstructure. A typical photograph of the microstructure taken at 100× magnification is shown in Fig. 5.64. The analysis of this photograph indicates that the forgings were normalized properly, and their microstructures are of a pearlite in a ferritic matrix form. All forgings were then turned, hobbed, and shaved using proper machining speeds and feeds. Before any heat treatment, each gear was inspected for the following parameters as illustrated in Fig. 5.65:

- Flatness of the rim and hub at four points 90° apart with respect to a “0” reference plane on the rim
- Diameter over pins readings
- Hub popping with respect to rim
- Lead and involute variations of four teeth

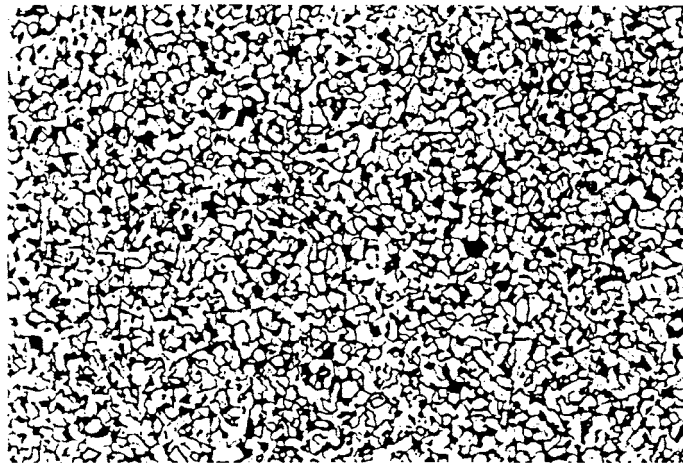
**Table 5.17 Material characteristics of rough steel forgings**

Gear forgings, normalized item 1 die 827, 8625-H steel

Heat No.	Chemical composition, %								Grain size (GS)
	C	Mn	P	S	Si	Ni	Cr	Mo	
654L005	0.25	0.94	0.11	0.013	0.22	0.53	0.52	0.20	Fine
654J3321	0.24	0.81	0.010	0.014	0.26	0.50	0.49	0.21	Fine

Heat No.	Jominy No.						
	J1	J2	J3	J4	J8	J12	J16
First heat	47	46	43	38	25	22	20
Second heat	45	46	41	35	26	22	...

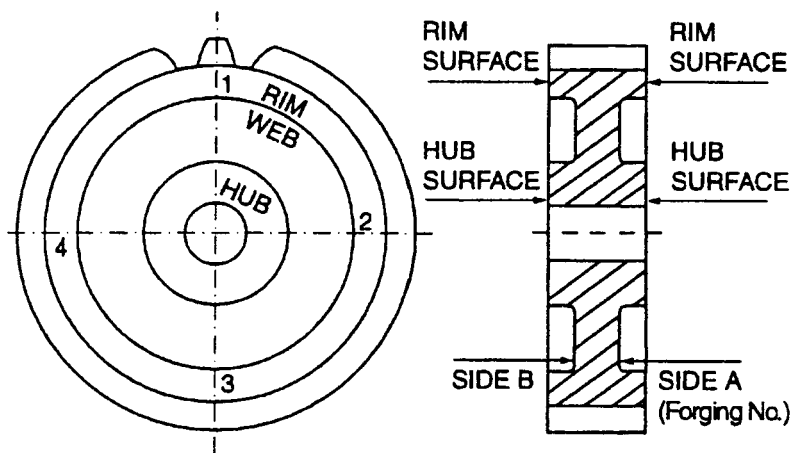


**Fig. 5.64** Typical microstructure of experimental gears. Microstructure analysis: the microstructure consists of ferrite and pearlite. There is no evidence of banding. Section location: gear hub. Process: 100×, etched 3% nital

**Heat Treatment.** To determine distortions, gears were heated to 930 °C (1700 °F), heat soaked, and carburized with nitrogen-methanol, after which the temperature was brought down to 845 °C (1550 °F), soaked and quenched using initial flow rate of oil at 24,000 gpm (high) followed by a 12,000 gpm (low) flow. Carburizing cycle times were calculated using Eq 1 and were set for effective case of 1.14 mm (0.045 in.). Gears were then allowed to cool to room temperature after which they were tempered in an oven at 120 °C (250 °F) for 6 h. Tempered gears were subsequently inspected for various distortion parameters. Sectioned gears also were inspected for metallurgical properties. Typical hardness traverse and carbon gradient from surface to the core of the gear teeth are shown in Fig. 5.66. The effective case depth and surface hardness of the gear as shown in this figure met the design requirements.

**Results.** The histogram (Fig. 5.67) of flatness distortions at the rim of the gear shows that 94.1% of the gears had an average rim distortion of less than or equal to 0.05 mm ( $\leq 0.002$  in.). Figure 5.68 illustrates the histogram of hub popping. Hub popping is defined as the movement of hub plane moving away from the rim plane of gears. This exhibit shows 100% of the gears had an average hub popping of less than or equal to 0.05 mm (0.002 in.), an excellent condition. A limited amount of such hub popping is not found to be detrimental to gear teeth parameters such as lead, involute, and so on, provided the plane of hub surface remains relatively flat and parallel to the plane of rim surface. Test results (Fig. 5.68) confirm the flatness and parallelism of hub and rim surfaces after heat treatment.

The growth of gear pitch diameter is again inherent in any carburized gear. The important thing is to maintain consistency of this growth. With consistent gear growths, the dimension on pre-heat-treat gears could be held for minimum stock removal during finish operations, if so required.



**Fig. 5.65** Gear distortion inspection format



The histogram (Fig. 5.69) shows that 94.2% of the gears had a growth within a narrow range, between 0.127 and 0.203 mm (0.005 and 0.008 in.).

The out of roundness of gear pitch diameter, defined by the differential of two diameter-over-pins readings at 90° spacing after carburizing, is an indication of the gear pitch diameter distortion. The histogram shows that 94.1% of the gears had a distortion of less than or equal to 0.05 mm ( $\leq$  0.002 in.). (Fig. 5.70).

Finally, lead and involute profile charts of the four teeth at 90° spacing were taken for each gear and compared with those taken prior to heat

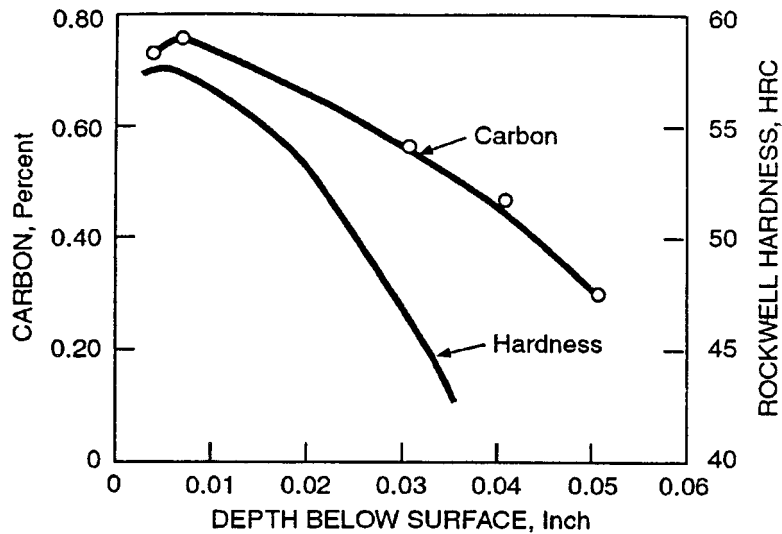


Fig. 5.66 Carbon and hardness gradient

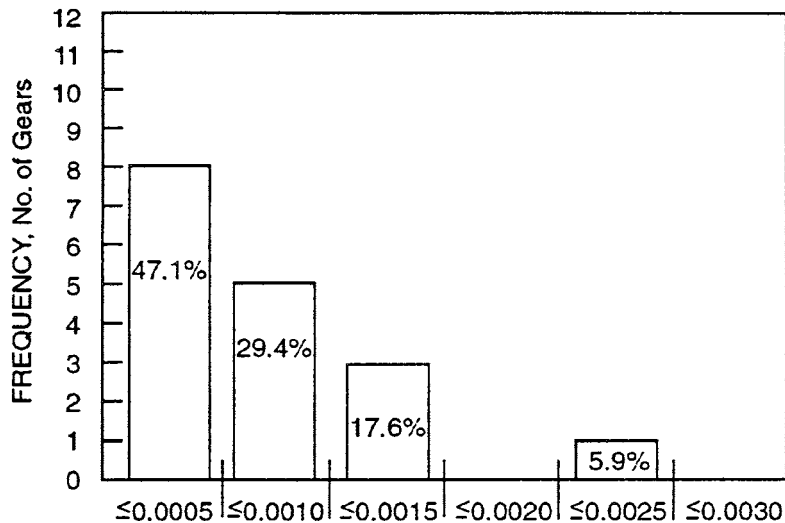


Fig. 5.67 Flatness distribution at rim, inch

treatment. Results show that the quality of both leads and involutes after heat treatment remained within acceptable distortion, an amount that could easily be removed by minor gear honing operations. Some typical lead and involute charts before and after heat treatment of these gears are shown in Fig. 5.71 and 5.72, respectively.

**Discussion of Results.** Gears selected in this investigation represented a typical high-volume power transmission gear made from forgings used in industrial gearboxes. The quality of this gear was AGMA class 9. The size, configuration, and quality requirement always presented a challenge

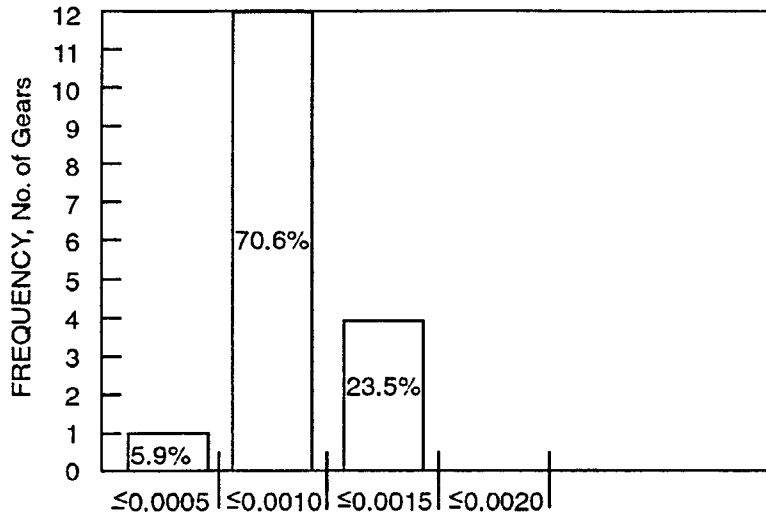


Fig. 5.68 Hub popping with respect to rim, inch

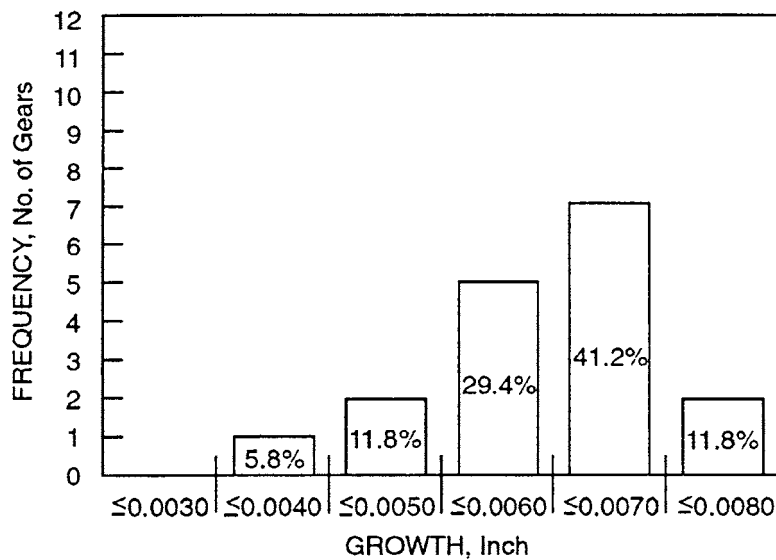


Fig. 5.69 Average growth over pins

to manufacture this gear economically due to the large amount of heat treat distortion experienced with the previous heat treat facilities (smaller quench tank with 80 °C, or 170 °F, quench oil, and low gpm flow rate, etc.). In fact, the leads of the gear teeth used to be distorted more than 0.229 mm (0.009 in.). The rim and hub flatness could not be kept below 0.40 mm (0.015 in.), and the pitch line runouts were more than 0.25 mm

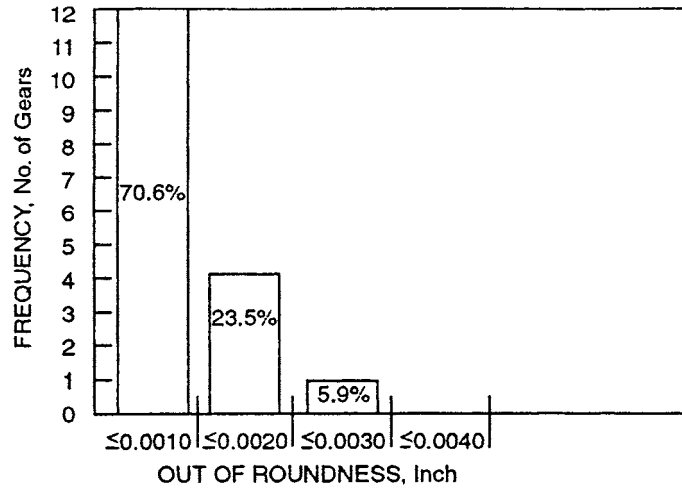


Fig. 5.70 Out of roundness

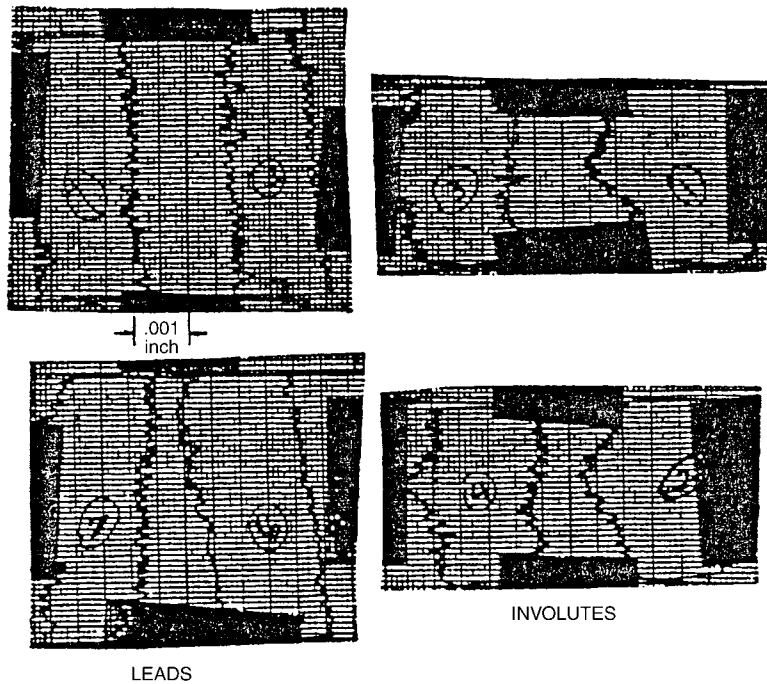


Fig. 5.71 Lead and involute charts before heat treatment

(0.010 in.). The results obtained in this investigation, as already depicted in various charts and histograms, proved that with improved furnace and quench systems, it was possible to carburize and free quench large gears and still achieve the quality required after heat treatment.

Results also indicate that gear flatness, hub popping, and distortion of leads and involutes were all interrelated. The flatter the gear and the less the hub popping were, the better the leads and involutes after heat treatment. In fact, with sufficient experimental data, it is possible to derive some empirical relationship between flatness and hub popping of gears to the distortion of leads and involutes of gear teeth. These will show how much a gear needs to be kept flat and restrained from hub popping for acceptable leads and involutes after heat treatment.

### Conclusions

The test results proved that a good furnace system can produce low-distortion gears. The amount of distortion found after heat treatment indicated gears could be hobbled, shaved, and honed (after heat treatment) to meet the design requirements of AGMA class 9 quality. With the existing heat treat facility, gears needed to be ground after heat treatment.

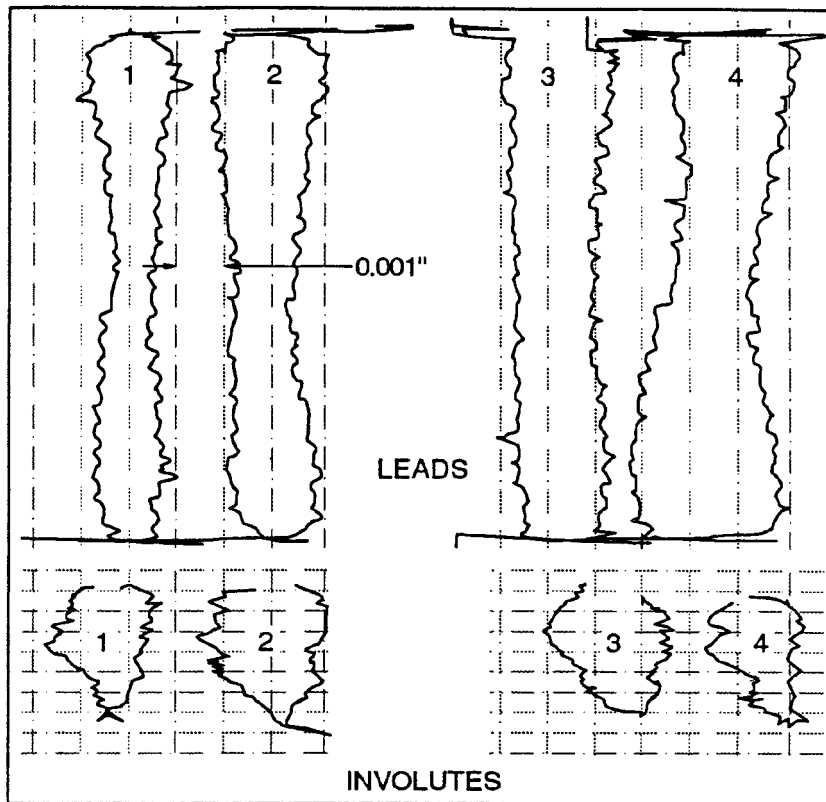


Fig. 5.72 Lead and involute charts after heat treatment

Although these conclusions were based on one trial run of this gear, it was certain similar results would be achieved for all gears of similar configuration, provided consistency of each individual operation prior to heat treatment is maintained as in this trial run. The consistencies are:

- The austenitic grain size of material through the part shall be ASTM 5 to 7
- Clean material, preferably to AMS 2300 or 2304 specification
- One forging heat code for each batch of gears. Proper normalizing of gear material with subsequent microstructure analysis for verifications
- Uniform metal removal (constant speed, feed, etc.) during each machining operation
- Uniform carburizing atmosphere with nitrogen-methanol system
- High, uniform flow of fast and hot quench oil with composition that allows quenching at approximately 120 °C (250 °F) for acceptable metallurgical properties of gears

# CHAPTER 6

---

---

## Nitriding Gears

NITRIDING is a case-hardening process used for alloy steel gears and is quite similar to case carburizing. The process primarily produces a wear- and fatigue-resistant surface on gear teeth and is frequently used in applications where gears are not subjected to high shock loads or contact stress above 1340 MPa (195 ksi) for AGMA grade 3, and 1190 MPa (172 ksi) for grade 2 materials. It is particularly useful for gears that need to maintain their surface hardness at elevated temperature. Nitriding of gears can be done in either a gas or liquid medium containing nitrogen. Industrial, automotive, or aerospace gears are quite often gas nitrided. Hence, this process is of interest to gear engineers. Recently, ion nitriding and computer-controlled nitriding (Nitreg process) are also being used in certain applications.

### Gas Nitriding Process

---

Gears to be nitrided are placed in an airtight container or oven and an atmosphere of ammonia ( $\text{NH}_3$ ) is supplied continuously while the temperature is raised and held between 480 and 565 °C (900 and 1050 °F) to produce the best combination of surface hardness and case depth. At this temperature,  $\text{NH}_3$  breaks down into atomic nitrogen and hydrogen according to the following reaction:



The atomic nitrogen slowly penetrates into the steel surface and combines with the base metal and the alloying elements such as aluminum, chromium, vanadium, and molybdenum that might be present in the steel selected to form hard nitrides of such elements. Of these, aluminum nitrides offer the highest surface hardness, whereas chromium, vanadium, and molybdenum nitrides result in a deeper and tougher case. Because nitriding takes place at a temperature well below the critical temperature

of steel, no molecular change in the grain structure is expected. Therefore, properly nitrided gears exhibit very little distortion and it is a common practice to finish machine gears prior to nitriding. Ideally, the only work required after nitriding is stripping of the mask used for selective nitriding. The masking is generally done with fine-grained copper or nickel plating of thickness not less than 0.025 mm (0.001 in.). Gas nitriding is carried out with gears that are already heat treated, quenched, and tempered for core hardness. This provides a strong, tough core with a hard wear-resisting case, usually harder than obtained by carburizing. Steels selected have carbon content somewhat higher than is employed for carburizing grades to provide support for the hard, brittle case. The chemical compositions of nitriding steels commonly used in gears are shown in Table 6.1.

To improve the quality of nitriding, some pre-nitriding requirements are important, including:

- Gears are to be free from decarburization. Nitriding a decarburized steel causes excessive growth and the case becomes very brittle and susceptible to cracking and spalling.
- Normalizing and subcritical annealing should occur prior to core hardening.
- Gears are to be core hardened and tempered.
- Nitriding temperature is to be at least 28 °C (50 °F) below the tempering temperature of core-hardened gears.

**Case Depth in Nitriding.** Nitrided gears do not require as much case depth as required in carburized gears. This is due to the fact that nitriding is used basically to increase the wear life of gears under a moderate load. The depth of case and its properties are greatly dependent on the concentration and type of nitride-forming elements in the steel. In general, the higher the alloy content, the higher is the case hardness. However, higher alloying elements retard the N<sub>2</sub> diffusion rate, which slows the case depth development. Thus, nitriding requires longer cycle times to achieve a given case depth than that required for carburizing. It is also to be noted that higher case depth does not increase the contact fatigue life of nitrided gears in the same ratio as it does in carburized gears. This is due to the fact that hardness drops quickly below the

**Table 6.1 Chemical compositions of nitriding steels commonly used in gears**

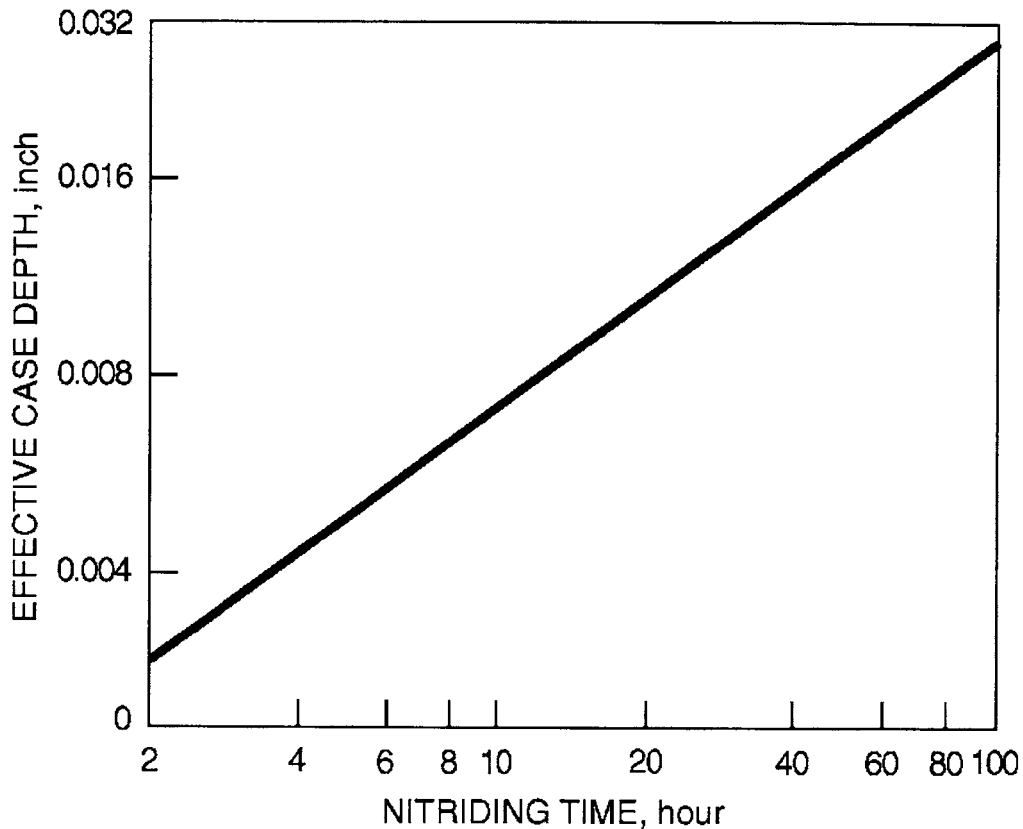
Steel	C	Mn	Si	Cr	Al	Mo	Ni
Nitralloy 135	0.35	0.50	0.30	1.20	1.00	0.20	...
Nitralloy 135M	0.41	0.55	0.30	1.60	1.00	0.35	...
Nitralloy N	0.23	0.55	0.30	1.15	1.00	0.25	3
AISI 4340	0.40	0.70	0.30	0.80	...	0.25	1
AISI 4140	0.40	0.90	0.30	0.95	...	0.20	...
31CrMoV9	0.30	0.55	0.30	2.50	...	0.20	...

surfaces of nitrided case, whereas, in a carburized case, the drop in hardness is very small. Recommended case depths on different diametral pitch (DP) gear teeth are given in Table 6.2.

**Nitriding Cycle Time.** Nitriding is a slow process and it takes hours to develop useful case depths on tooth surfaces. Figure 6.1 shows some typical cycle times for nitriding versus case depth relationship for

**Table 6.2 Recommended case depths for alloy steel gears**

Diametral pitch (DP) of tooth	Case depth	
	mm	in.
20	0.127–0.254	0.005–0.010
16	0.203–0.330	0.008–0.013
10	0.305–0.457	0.012–0.018
8	0.356–0.508	0.014–0.020
6	0.406–0.559	0.016–0.022
4	0.508–0.711	0.020–0.028



**Fig. 6.1** Nominal time for different nitrided case depths



commonly used materials, such as Nitralloy 135M, Nitralloy N, AISI 4140, AISI 4330M, and AISI 4340.

**The effective case depth** of a nitrided gear tooth should be the depth below the tooth surface at which the minimum hardness of 50 HRC is met for aluminum and high-chromium steels. On the other hand, low-chromium steels do not develop surface hardnesses above 50 HRC. For these steels, effective case depth at 40 HRC works very well (courtesy: D. Dudley, *Handbook of Practical Gear Design*, Technomic Publishing Company, Inc.). In the case of some gear materials with core hardness approaching 40 HRC, a higher hardness, such as 45 HRC, may be considered for an effective case depth measurement.

Effective case depth is determined by a properly calibrated microhardness tester using a 500 g load and Knoop indenter. The microhardness impressions should be spaced so that they are not disturbed by adjacent impressions. There should be positive assurance that the surface being tested is normal to the indenter. Surfaces to be microhardness tested should be properly polished (scratch-free) and lightly etched in 4% nital solution. When microhardness tests indicate unacceptable results, two additional sets of readings should be obtained—if possible, one on each side of the original set. On small gears, the additional sets may be obtained on adjacent teeth. The three sets of readings should then be averaged. The hardness values are then plotted against their depth from the surface, and a curve is drawn connecting the points. Determine the depth at which the minimum hardness level of 50 HRC crosses the curve.

**Total case depth** should be determined metallographically using a suitable etch procedure. On an etched tooth section two identifiable bands appear, dark and light. The depth of the dark band is considered to be the total case depth.

**Surface Hardness.** Because case depth of nitrided gears is generally low, surface hardness measurements are recommended to be taken in Rockwell 15N scale. Table 6.3 shows some typical surface hardnesses that can be attained after nitriding different alloy steel gears.

Both Nitralloy 135M and Nitralloy N are outstanding materials for gears. Some typical core properties of these two steels before and after nitriding are shown in Table 6.4.

Core hardness of nitrided gears is measured in the center of a tooth, as illustrated in Chapter 5 (Fig. 5.14). Realistically it should be measured at the locations as shown in Fig. 5.15.

**Table 6.3 Surface hardness of gear tooth**

Material	Minimum hardness, Rockwell ISN
Nitralloy 135M	92.5
Nitralloy N	92.5
Nitralloy E Z	92.5
AISI 4140, 4330, 4340	85.5

**Table 6.4 Properties of Nitralloy 135M and Nitralloy N**

Alloy	Tensile strength		Yield point		Elongation in 2 in., %	Reduction of area, %	Brinell hardness at core
	MPa	ksi	MPa	ksi			
<b>Nitralloy 135 M</b>							
Before nitriding	950	138	830	120	26	60	320
After nitriding	950	138	760	110	4	17	310
<b>Nitralloy N</b>							
Before nitriding	910	132	790	114	2	59	277
After nitriding	1310	190	1240	180	6–15	43	415

## Recommended Tip and Edge Radii of Teeth

To avoid chipping tooth edges in case of any misalignment of gears during service, it is important to remove sharp corners of gear teeth before nitriding. This is achieved by rounding off the edges. Suggested edge radii are given in Table 6.5.

## White Layer in Nitrided Gears

Besides shallow case depth, nitrided gears seem to have a layer of super rich nitrides of iron on the tooth surface. This layer of compound zone remains unetched in nital (3% nitric acid in ethyl alcohol) and appears white under a microscope. For this reason, the layer is called the “white layer” and consists of a mixture of gamma prime and epsilon iron nitrides. Below the compound nitride zone is the diffusion zone containing precipitated alloy nitrides. From the mechanical strength viewpoint, the white layer is very hard and brittle. The brittleness of this layer is detrimental to gear life, particularly when gears experience misalignment during service. The thickness of the white layer may vary from one material to the other. It is also found that the process used during nitriding has a significant effect on the thickness of this white layer. For example, single-stage gas nitriding may result in a white layer of 0.025 to 0.076 mm (0.001–0.003 in.) on materials normally used for gears. On the other hand, it is possible to hold this thickness to 0.0127 mm (0.0005 in.) or less with a two-stage gas nitriding process, also known as diffusion or Floe process. This double-stage process uses two nitriding cycles, the first

**Table 6.5 Tip and edge radii**

Diametral pitch (DP)	Maximum edge radius		Maximum tip radius	
	mm	in.	mm	in.
2–5	1.524	0.060	0.381	0.015
6–10	1.270	0.050	0.254	0.010
12–20	0.762	0.030	0.127	0.005

similar to the single-stage process (except for duration). In the first stage, gears are nitrided at a 15 to 30% dissociation rate of  $\text{NH}_3$  for 4 to 12 h at a temperature of approximately 505 to 560 °C (940–1040 °F). The longer second stage takes place at a temperature of 525 to 565 °C (975–1050 °F) with a dissociation rate of 80 to 85%. To get this high dissociation rate of  $\text{NH}_3$ , an external dissociator is used. Some typical case hardnesses and depths achieved with double-stage nitriding cycles are shown in Table 6.6.

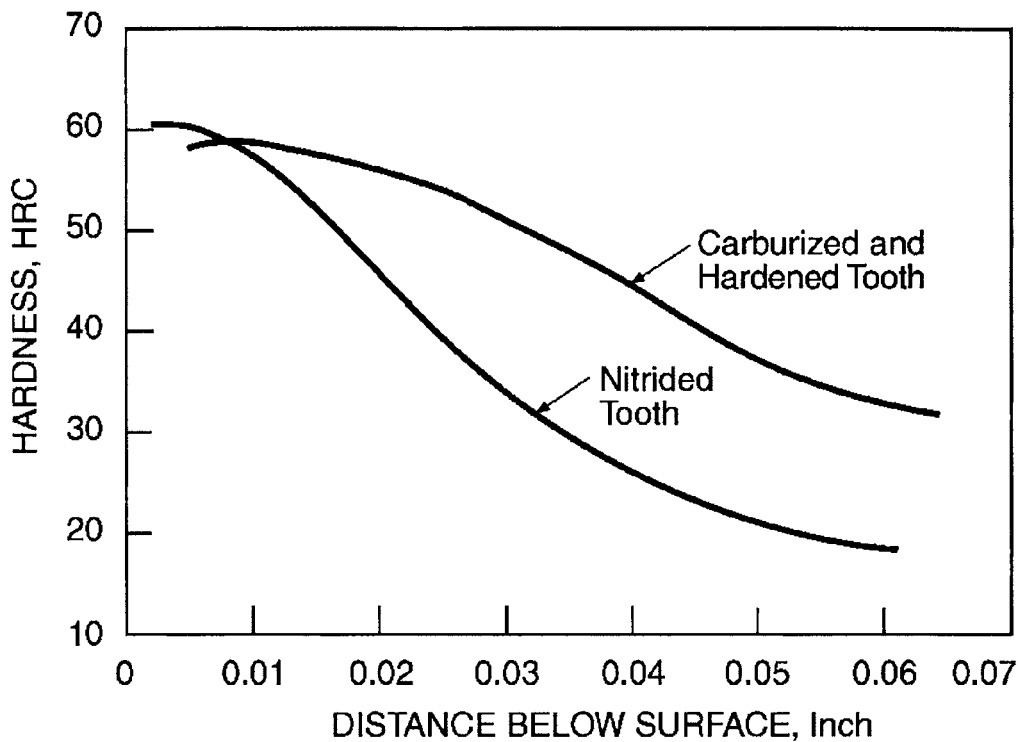
Any presence of white layer (above 0.025 mm, or 0.001 in.) on the tooth surface is considered very detrimental to the fatigue life of nitrided gears. To improve fatigue life of such gears, as much of this white layer as possible must be removed after nitriding. The most commonly used processes for the removal of this layer are honing, acid pickling, and fine sandblasting. Of these, sandblasting is the most expeditious method, but it destroys the surface finish and profile of gear teeth. Honing is a much superior process, but it is extremely slow. Frequently, a combination of these processes is used to remove the white layer and ensure the quality of the tooth surface and optimize cost. For gear quality (AGMA class 10 and above), honing is recommended.

In case the gears need to be finish-machined to reduce white-layer thickness, it is important to make sure there is only minimal removal of

**Table 6.6 Double-stage gas nitriding cycles**

Steel	Cycle	Effective case depth at 50 HRC		Maximum white layer thickness		Minimum hardness at surface, Rockwell 15 N	Core hardness, HRC
		mm	in.	mm	in.		
Nitralloy 135M	10 h at 525 °C (975 °F), 28% dissociation, 50 h at 550 °C (1025 °F), 84% dissociation	0.457	0.018	0.0127	0.0005	91–92	32–38
Nitralloy N	10 h at 525 °C (975 °F), 28% dissociation, 50 h at 525 °C (975 °F), 84% dissociation	0.356	0.014	0.0127	0.0005	91–92	38–44
AISI 4140	10 h at 525 °C (975 °F), 28% dissociation, 50 h at 525 °C (975 °F), 84% dissociation	0.635	0.025	0.0178	0.0007	85–87	32–38
AISI 4340	10 h at 525 °C (975 °F), 28% dissociation, 50 h at 525 °C (975 °F), 84% dissociation	0.635	0.025	0.0178	0.0007	84.5–86	32–38
31CrMoV9	10 h at 525 °C (975 °F), 28% dissociation, 50 h at 525 °C (975 °F), 84% dissociation	0.559	0.022	0.0178	0.0007	89.3–91	27–33

the case. Removal of the case is detrimental to the life of nitrided gears, due to the fact that the hardness of a nitrided surface drops very rapidly along the depth of the case, as depicted in Fig. 6.2. This figure also shows the differences in hardness versus case depth gradient of a nitrided surface compared to a carburized and hardened surface. The difference in these two gradients narrows as DP of gears increases. For 20 DP and higher, to avoid removal of any case, complete removal of white layer from a nitrided case is not advocated. Recent investigation on this subject also shows that a white layer on the order of 0.0127 mm (0.0005 in.) or below does not affect the fatigue properties of single-stage nitrided gears, particularly gears that are not heavily loaded (contact stress of 1030 MPa, or 150 ksi, or below). In this region of contact stress, the elastic deformation of contact surface between two mating teeth is usually negligible, and, consequently, tensile stress that develops at the interface of the contact zone is also negligible. Furthermore, the maximum shear stress below the surface at the load center is also relatively small for gears that are not heavily loaded. Hence, the failure of such gears is not due to pitting fatigue but rather to simple wear. To enhance wear life of nitrided gears it is thus necessary to have good surface finish (0.61  $\mu\text{m}$ , or 24  $\mu\text{in.}$ ,



**Fig. 6.2** Comparison of hardness gradients for a carburized tooth and a nitrided tooth

or better) and high surface hardness (60 HRC and higher) on gear teeth. While surface finish depends primarily on the gear cutting and finishing processes, the surface hardness depends on the alloying elements in the gear material. As discussed earlier, aluminum alloy in nitriding type steels (Nitalloy 135M) helps to achieve higher surface hardness, whereas alloying elements such as chromium (AISI 4330M) help to obtain higher case depth. With good process controls, Nitalloy 135M provides surface hardness of 60 to 62 HRC and is considered very suitable for gears that are not very heavily loaded. These gears, when nitrided with a diffusion cycle (two-stage process), are not expected to have more than 0.0127 mm (0.0005 in.) of white layer on tooth surfaces.

Now, the question is whether a white layer in the range of 0.0127 mm (0.0005 in.) is acceptable for highly loaded gears (contact stress of approximately 1340 MPa, or 195 ksi, for AGMA grade 3 materials). This, of course, depends on the mechanical properties of the white layer and the magnitude of contact stress that is induced by the applied load. In analyzing the properties of the white layer, an interesting characteristic is revealed. It is found that the white layer produced in a two-stage process is somewhat softer and more ductile than the white layer produced in the single-stage process. This allows the white layer of a two-stage process to withstand some elastic deformation. Results obtained so far indicate such a white layer of 0.0127 mm (0.0005 in.) does not detrimentally affect the fatigue life of heavily loaded nitrided gears. The failure in these applications is predominantly controlled by resistance to case crushing at the case-core boundary. To resist this type of crushing, a deeper case with high core hardness is desirable. Materials such as Nitalloy N and AISI 4340 offer these characteristics.

## General Recommendations of Nitrided Gears

---

Several guidelines should be followed when nitriding gears:

- Use a two-stage nitriding process wherever possible.
- Use Nitalloy 135M or a similar material with aluminum alloy for gears that are not very heavily loaded. Allow a maximum 0.0127 mm (0.0005 in.) of white layer on tooth surface. A minimum core hardness of 30 HRC is recommended.
- For highly loaded gears where the mode of failure is primarily due to case crushing, select steels with chromium, such as Nitalloy N and AISI 4340. Core-harden tooth to a minimum of 35 HRC.
- All nitrided gear teeth should have proper tip relief on their profile to avoid tip loading that may occur due to tooth deflection or misalignment of gears. No sharp corners are allowed on tooth tips.

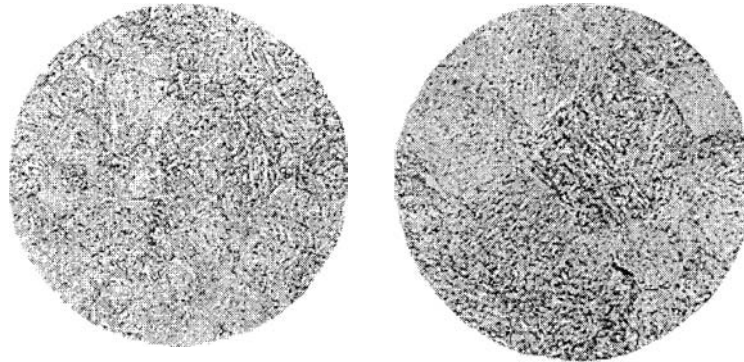
- Honing or grinding (not to exceed 0.025 mm, or 0.001 in., stock removal) is acceptable to remove the white layer, but only if such removal is essential.
- For satisfactory nitriding, liquid-abrasive blast (200–1200 grit size) surfaces prior to nitriding. Burnished or polished surfaces do not nitride satisfactorily.
- No shot peening is necessary for nitrided gears.

## Microstructure of Nitrided Cases and Cores

As with carburizing, the microstructure of a nitrided gear tooth changes from the surface to the core. Preferred microstructures for various grades of nitrided gears are given in Table 6.7. Metallographic standards for core structures and nitrided case are illustrated in Fig. 6.3 and 6.4.

**Table 6.7 Recommended material, attainable hardness, and case microstructure for different applications of nitrided gears**

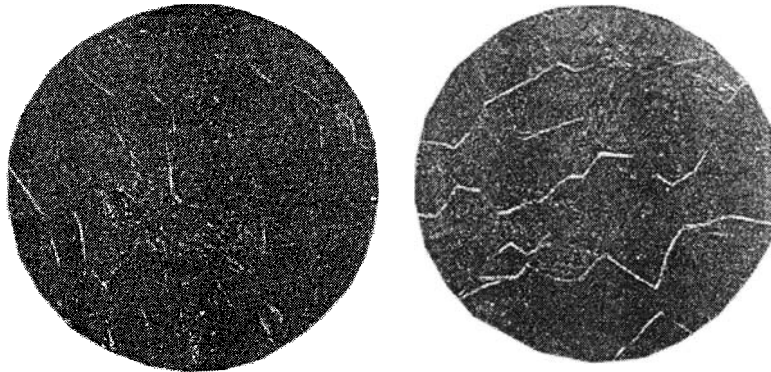
Material	Hardness		Core, HRC	Requirement
	Cased surface min, Knoop 500 gram	Uncased surface, HRC		
<b>Grade A, gas nitrided (double stage)</b>				
Nitralloy 135	754	32–38	32–38	Case: Maximum white layer of 0.0127 mm (0.0005 in.) permitted on working surfaces of gear and spline teeth, other surfaces 0.0203 mm (0.0008 in.) max. No soft spots, microcracks, or heavy nitrogen penetration along grain boundaries. No evidence of improper heat treatment in prior processing, excessive ammonia, or excessive temperature. Heavy continuous iron nitride network at tooth tip may be cause for rejection. Core: The core structure should be essentially tempered martensite. Ferrite patches and transformation products (bainite and pearlite) should not exceed 1.586 mm (1/16 in.) in length and width as measured at 250×.
Nitralloy N	732	38–44	38–44	
AISI 4140	540	32–38	32–38	
AISI 4340	540	32–38	32–38	
<b>Grade B, gas nitrided (double stage)</b>				
AISI 4130	500	28–36	23–36	Case: Maximum white layer of 0.0203 mm (0.0008 in.). Tempered martensite with nitride needles. No evidence of decarburization or improper heat treatment. Complete grain boundary network is acceptable. Core: Tempered martensite. Ferrite patches and transformation products should not exceed 3.175 mm (1/8 in.) in width and length as measured at 250×.
AISI 4140	500	28–36	28–36	
AISI 4340	500	28–36	28–36	
Nitralloy 135	754	30–38	30–38	
Nitralloy N	732	38–44	38–44	
<b>Grade C, liquid salt and gas nitrided (single stage)</b>				
AISI 4340	466	28–36	28–36	Case: Compound layer 0.025 mm (0.001 in.) max. Diffusion zone per drawing requirements. Microstructure per AMS 2755
AISI 4140	466	28–36	28–36	
AISI 4130	466	28–36	28–36	
Nitralloy 135	754	28–36	28–36	



(a)

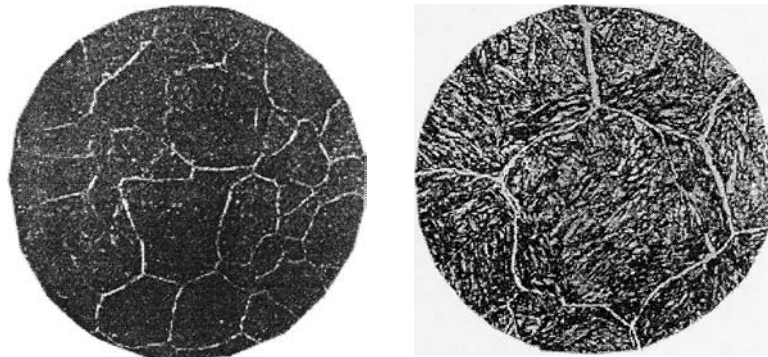
(b)

**Fig. 6.3** Metallographic standards for nitrified core structure. (a) Desirable tempered martensite core structure for grades A and B. (b) Maximum acceptable large-grained tempered martensite core structure for grades A and B



(a)

(b)



(c)

(d)

**Fig. 6.4** Metallographic standards for nitrided case structure. (a) Desired nitrided case showing small amount of grain boundary nitride; acceptable for grade A. Dark field illumination. (b) Nitride case with some continuous grain boundary nitrides; maximum acceptable for grade A. Dark field illumination. (c) Nitride case with an increase in continuous grain boundary nitride; maximum acceptable for grades A and B tooth tip. Dark field illumination. (d) Nitride case with complete grain boundary nitrides; not acceptable for grades A or B. Dark field illumination

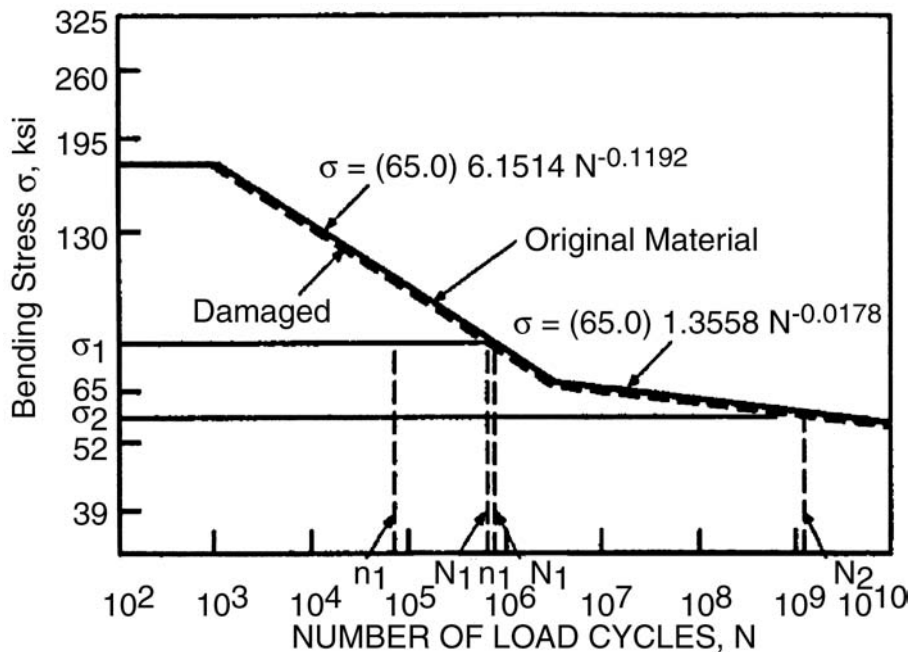
## Overload and Fatigue Damage of Nitrided Gears

One major drawback of nitrided gears is the reduction of fatigue life subsequent to any momentary overload. The most popular theory of adequately representing the fatigue life of a mechanical element, such as gear teeth subjected to a cumulative fatigue damage, was developed by Palmgren and Miner. This theory is popularly known as Miner's Rule and is now widely used to calculate both bending and pitting fatigue life of gears. According to this theory, failure occurs when the following is satisfied:

$$\sum_i D_i = \sum_i \frac{n_i}{N_i} = 1 \quad (\text{Eq 2})$$

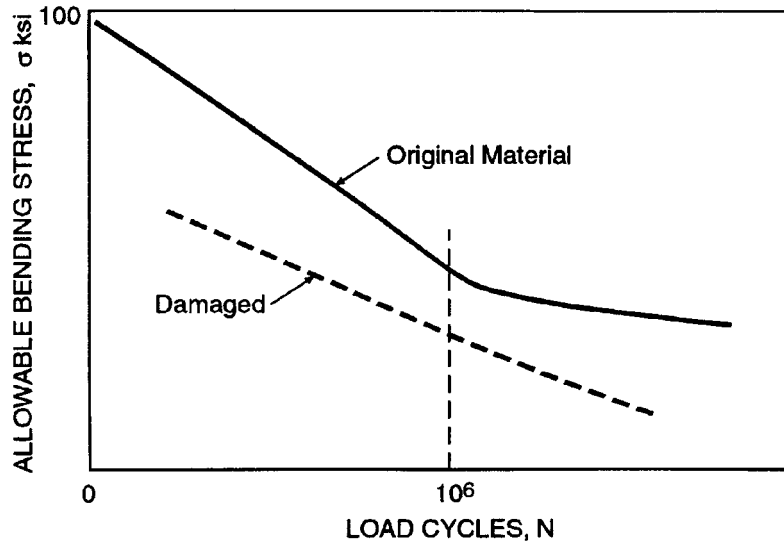
where  $D_i$  is the damage done to a part due to a certain stress level,  $n_i$  is the number of cycles the part experienced at this stress level, and  $N_i$  is the number of cycles to failure at that stress level.

Figure 6.5 shows a typical endurance ( $S-N$ ) curves of a gear steel. For gears carburized and hardened, the  $S-N$  curve for original and damaged material due to momentary overload remains more or less the same. But unfortunately, this is not the case with gears that are nitrided. Tests show that the nitrided gears do not have the same overstressing capability as the



**Fig. 6.5** Bending-fatigue life of original and damaged carburized and hardened gears





**Fig. 6.6** Bending-fatigue life of original and damaged nitrided gears

carburized ones. In fact, the damaged endurance limit of momentarily overloaded nitrided gears seems to be quite a bit below that of virgin material, as depicted in Fig. 6.6. Therefore, it is advisable to consider this phenomenon while determining the fatigue life of nitrided gears that may be subjected to occasional overload. However, that the life of nitrided gears may also deteriorate when they are subjected to a rated load that varies widely in a very short time period is relatively unknown. A case study on the failure of such gears under wide fluctuating load is presented at the end of this Chapter.

## Bending-Fatigue Life of Nitrided Gears

To increase bending-fatigue life it is beneficial to have compressive stress at the surface of the tooth root fillet, the location of maximum bending stress. The mechanism for obtaining the compressive stress on a nitrided surface is to restrict the growth of case by the core during nitriding process. For small DP gear teeth with the section size much greater than the hardened case, the expansion in the nitrided layer cannot alter the dimensions of the tooth. This action simply tends to stretch the core and, in so doing, places the surface in compression. On the other hand, in large DP (smaller tooth section) gears, the case growth cannot be restricted by a thinner section of the tooth and results in greater growth, which generates excessive tensile stress in the case. This lowers the residual compressive stress in the case and thereby reduces the fatigue life. This is why small DP nitrided gears show higher bending fatigue life than large DP nitrided gears.

**Table 6.8 Case depth and cost for Nitralloy 135M**

Case depth		Cost factor
mm	in.	
0.254	0.010	1.0
0.004	0.012	1.0
0.356	0.014	1.4
0.406	0.016	1.6
0.457	0.018	2.0

**Table 6.9 Case depth tolerances and cost for Nitralloy 135M**

Case depth tolerance		Cost factor
mm	in.	
±0.051	±0.002	1.4
±0.076	±0.003	1.0
±0.102	±0.004	0.8
±0.127	±0.005	0.7

Note: Similar cost factor is applicable to all other nitriding materials.

**Table 6.10 Surface coverage and cost factor**

Surface coverage	Cost factor
All over	1.0
Partial	3.5

Note: The cost of masking and copper plating for selective coverage contribute to high cost factor.

## Nitriding Cost

Tables 6.8 through 6.10 show some comparative cost for different case depth, case tolerance, and surface coverage.

**Case Depth.** Higher case depth requires a longer nitriding cycle with an increase in cost. Steels with chromium need shorter nitriding cycles than steels with aluminum for the same case depth. Cost factors for one nitriding steel, Nitralloy 135M, are given in Table 6.8.

**Case Depth Tolerance.** Wider case depth tolerance is preferred for reduced cost, as noted in Table 6.9.

**Surface Coverage.** Partial coverage increases cost and should be avoided (Table 6.10).

## Distortion in Nitriding

As with any other heat-treating process, nitriding causes gears to experience distortion, although its severity is less in comparison to that

with other processes because this process is carried out at a relatively low temperature, approximately 510 °C (950 °F). Because of the low temperature, no phase transformation of steel, the major cause of distortion, takes place. The small dimensional changes that occur are due to heating and cooling mechanisms and the gear blank configuration. Sometimes, higher distortion is observed due to high case depth requirements in some gears that require many hours of nitriding. In general, gas-nitrided gears with a case depth less than 0.254 mm (0.010 in.) do maintain the same AGMA quality level after nitriding. Gears with case deeper than 0.254 mm (0.010 in.) experience some distortion resulting in lower quality level. Furthermore, pitch diameter (PD) and DP of a gear tooth are also important parameters that influence distortion. Large PD with a small DP tooth distorts more than a small PD with a large DP tooth. Distortion is also influenced by the material selected. Some materials distort more than others. In general, distortion of gears after nitriding is low. Occasionally, the distortion becomes high due to large size and configuration of gears (e.g., internal gears in epicyclic arrangements). Higher distortion is also noticed in gears with selective nitriding (e.g., nitriding of teeth only). Table 6.11 presents general distortion ratings of various steels after single-stage gas nitriding.

Although some distortion is always present in any type of nitriding, the process has a unique advantage: reproducibility of the distortion in batch after batch of gears. Gears of identical geometry and similar metallurgical quality distort exactly the same way. This means compensation for expected distortions can be made during tooth cutting prior to nitriding.

---

## European Nitriding Steels

---

Nitriding steels used in the United States fall in one of two groups: aluminum-containing Nitralloys and AISI low- or high-alloy steels. There is, however, a wide gap between the characteristics of these two groups of steels, which, in Europe, is filled by CrMo and CrMoV steels with 2.5 to 3.5% Cr. Chromium provides good hardenability and higher hardness in

**Table 6.11 Distortion ratings of common nitriding gear materials**

Material	AMS specification	AMS quality	Hardness, HRC		Distortion rating
			Case	Core	
Nitralloy 135M	6471	2300	60–65	32–36	Good
Nitralloy EZ	6475	2300	60–65	34–38	Good
Nitralloy N	6475	2300	60–65	40–44	Good
AISI 4140	6349	2300	50–55	25–32	Good
AISI 4340	6414	2300	48–53	28–34	Good
Maraging 300	6419	2300	57–59	52–54	Excellent

nitrided case than AISI low-alloy steels do. Molybdenum decreases softening on tempering so that high strengths can be retained even after tempering at well over the nitriding temperature. It also minimizes susceptibility to embrittlement during nitriding and increases hardenability and hot hardness. Vanadium permits easier control of heat treatment and gives higher hot hardness.

For surface hardness and toughness, the nitrided CrMo and CrMoV steels occupy a position in between Nitralloy 135M and AISI low-alloy steels. Because of lower case hardness, these materials are less brittle. Furthermore, they are less sensitive to grinding cracks and have higher hardenability. Also, they can be heat treated to higher core hardness prior to nitriding. For example, 3.5Cr-1Mo, a British Steel (EN 40C), can be heat treated to 375 to 444 Brinell hardness in sections up to 63.5 mm (2.5 in.), whereas Nitralloy 135M can be heat treated to only 248 to 302 Brinell hardness in that size.

In addition, the steels with 2.5 to 3.5% Cr come with low non-metallic inclusions (higher cleanliness), even in the air-melted condition, whereas the aluminum-containing steels, such as Nitralloy 135M, require vacuum melting or degassing to achieve similar cleanliness. In general, the cleaner the material, the lower is the distortion during any hardening process. Nitrided gears made from air-melted CrMo steels produce negligible distortion. A case history of successful nitriding of a gear is presented at the end of this Chapter.

## Applications

While carburizing is the most effective surface-hardening method, nitriding excels when gear tooth geometry and tolerances before heat treating need to be maintained without any finishing operation, such as grinding after heat treatment. Although, through-hardening is capable of maintaining close tooth dimensional tolerances, the process cannot provide sufficient wear and pitting resistance. This is why nitriding is an alternative to carburizing especially for lightly loaded gears.

The major disadvantage of nitrided gears is their inability to resist shock load due to inherent brittleness of the case. Also, nitrided gears do not perform well in applications with possible misalignment during which the highly brittle nitrogen oxides on tooth edges break off and may go into the gear mesh.

The quality of nitrided gear teeth is not as good as carburized, hardened, and ground gears. Grinding to improve tooth geometry is not recommended for nitrided gears because this may detrimentally affect their load carrying capability if more than 0.025 mm (0.001 in.) stock is removed.

## Case History A: Nitriding

---

The improved distortion characteristics of CrMo steel are well known. In the design of the sun pinion and planets of an epicyclic gear reducer, one such steel, 722-M24 (EN-4B) with 2.9 to 3.5Cr and 0.4 to 0.7Mo is selected. Some typical tooth geometry (involute and lead) charts for the sun pinion before nitriding are shown in Fig. 6.7 and 6.8. Figure 6.9 shows the pinion details. The primary manufacturing processes used for the pinion are:

- Normalization of forgings
- Turning of blanks
- Stress relief
- Hobbing and deburring
- Heat treating for core hardness
- Grinding of teeth to AGMA quality class 12
- Inspection
- Gas nitriding all over
- Honing teeth
- Cleaning and inspection

The combination of material property and the manufacturing processes result in a very low distortion of tooth geometry, as illustrated in Fig. 6.10 and 6.11. The quality of tooth geometry can be further improved, if needed, by grinding tooth geometry before nitriding that includes expected distortion. In the case of planet gears using similar material, distortion over the acceptable level is sometimes noticed. To compensate for this distortion, a small grind stock (0.025 mm, or 0.001 in., max) is allowed to pre-nitride grinding, which is subsequently finish-ground to size after nitriding. Because hardness of a nitrided surface drops rapidly along case depth, all the process variables during nitriding are precisely controlled to maintain tooth surface hardness of approximately 62 HRC. This allowed the manufacturer to achieve a minimum of 60 HRC at the

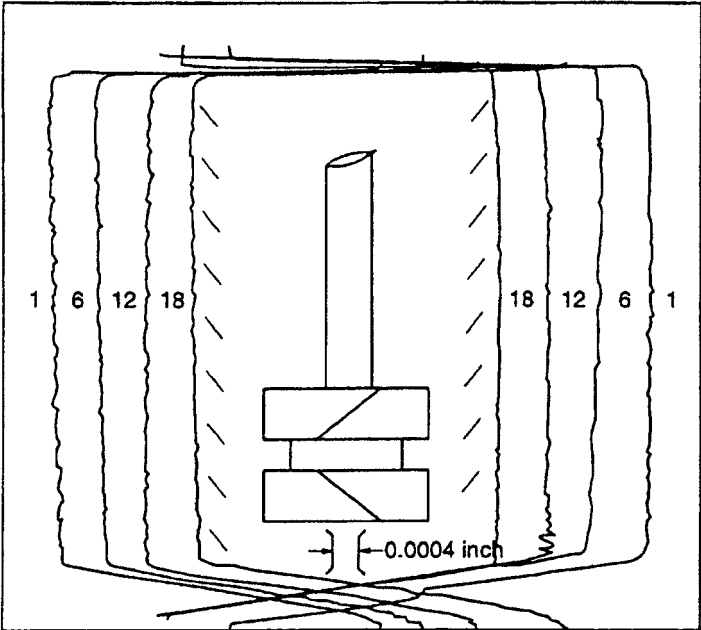


Fig. 6.7 Involute profiles of sun pinion teeth before nitriding

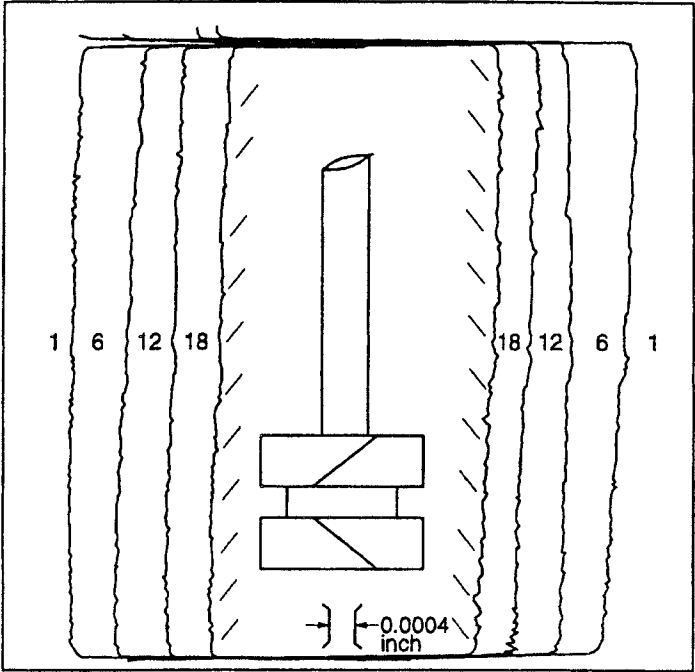
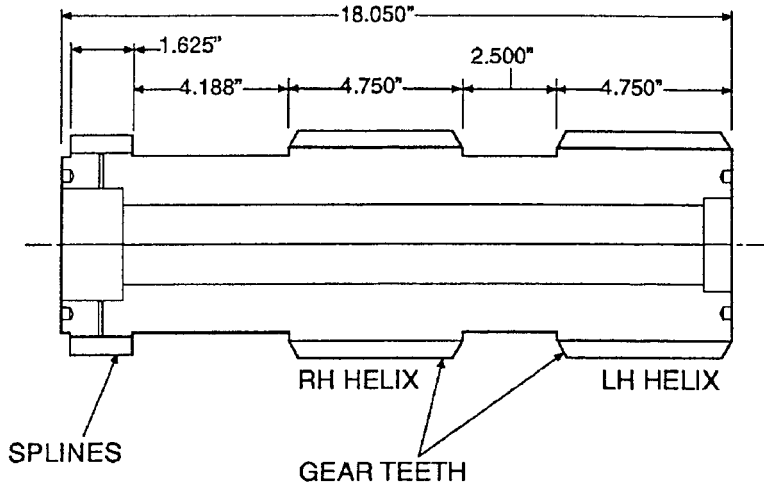
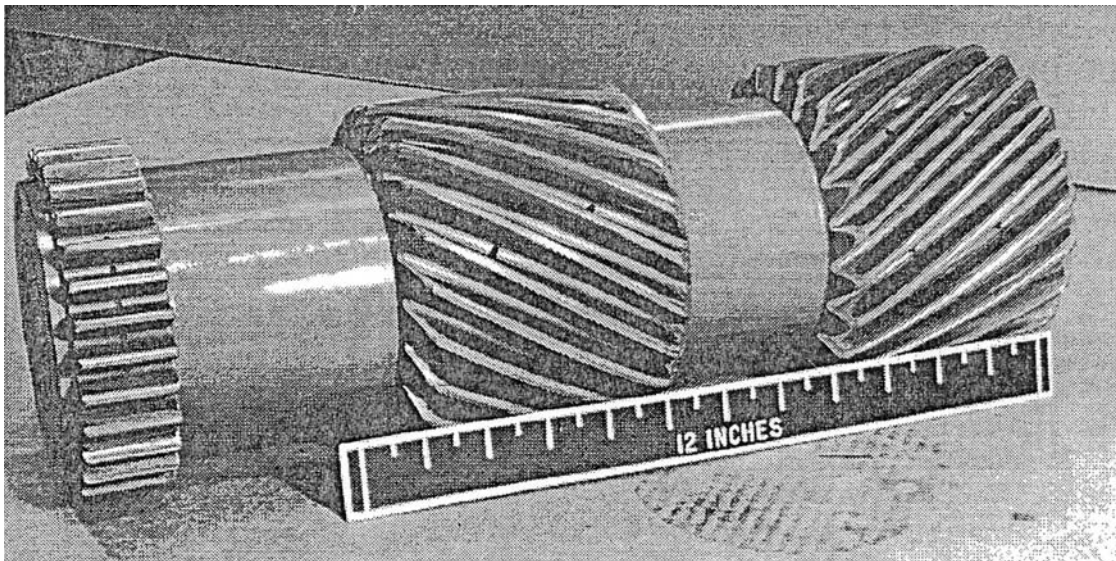


Fig. 6.8 Lead of sun pinion teeth before nitriding



No. of Teeth: 24  
 DP: 5  
 PA: 22.5°  
 Helix Angle: 30°  
 Quality Level: AGMA Class 10

(a)



(b)

**Fig. 6.9** Sun pinion. (a) Basic dimensions. LH, left hand; RH, right hand; DP, diametral pitch; PA, pressure angle. (b) Photograph of sun pinion shown in part (a)

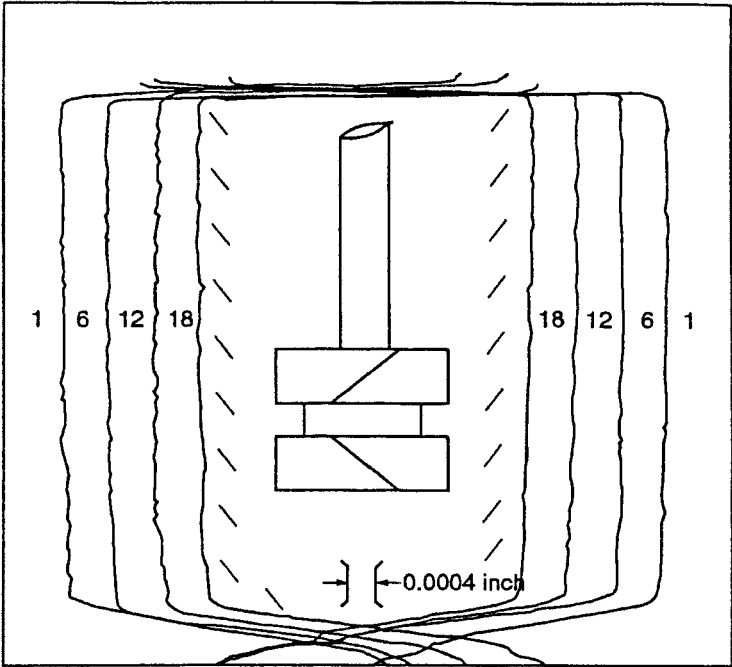


Fig. 6.10 Involute profiles of sun pinion teeth after nitriding

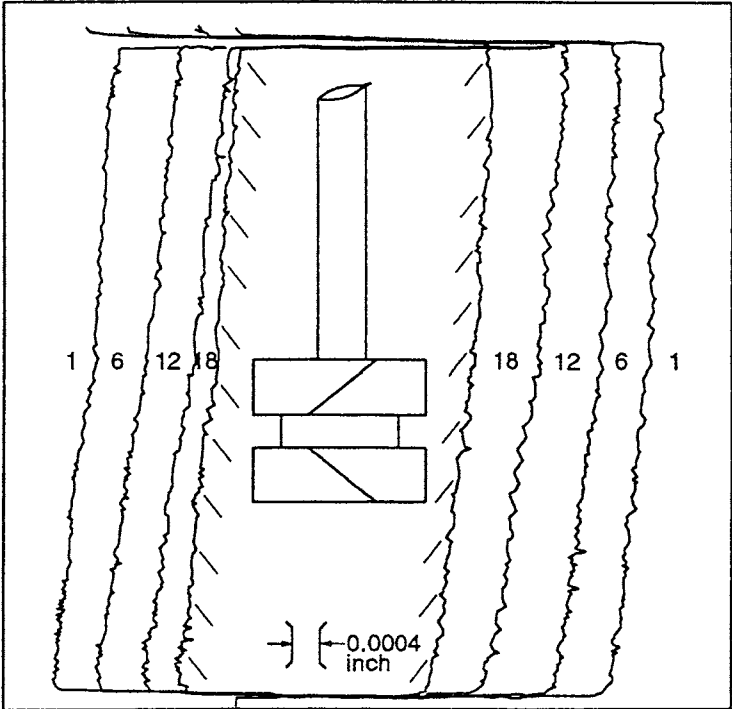


Fig. 6.11 Lead of sun pinion teeth after nitriding



surface after finish grinding. Similar encouraging results are also reported with 31CrMoV9, a DIN (German) standard material with chemical composition of 2.3 to 2.7Cr, 0.15 to 0.25Mo, and 0.1 to 0.2V.

In addition, all of these materials offer some additional benefits. It is reported that the microstructure and surface texture of the white layer produced during nitriding are such that the coefficient of friction during sliding of teeth is significantly reduced, thereby improving the scuffing life of gears.

## Case History B: Failure of Nitrided Gears

---

Case carburized and hardened gears are known to operate satisfactorily both under steady and overload conditions. Nitrided gears, on the other hand, seem to perform well only under steady load. Shock loads detrimentally affect the life of nitrided gears. Thus, nitrided gears are rarely used in applications that experience occasional shock loads. However, that the life of nitrided gears may also deteriorate when subjected to a rated load that varies widely in a very short time period is relatively unknown. Although, such load spectrums are not very common, sometimes these are observed in gas turbogenerator applications. An analysis of a gas turbogenerator load during startup shows that load fluctuations occur whenever the fuel-control system malfunctions. In this chapter, a case study is presented on the failure of nitrided gears used in a gearbox subjected to a load with wide fluctuations.

**Failed Gearbox.** The gearbox is of star epicyclic configuration and is used as a speed reducer in between a 10.4 megawatt (mW) gas turbine and an electric generator. The general characteristics of the gearbox are:

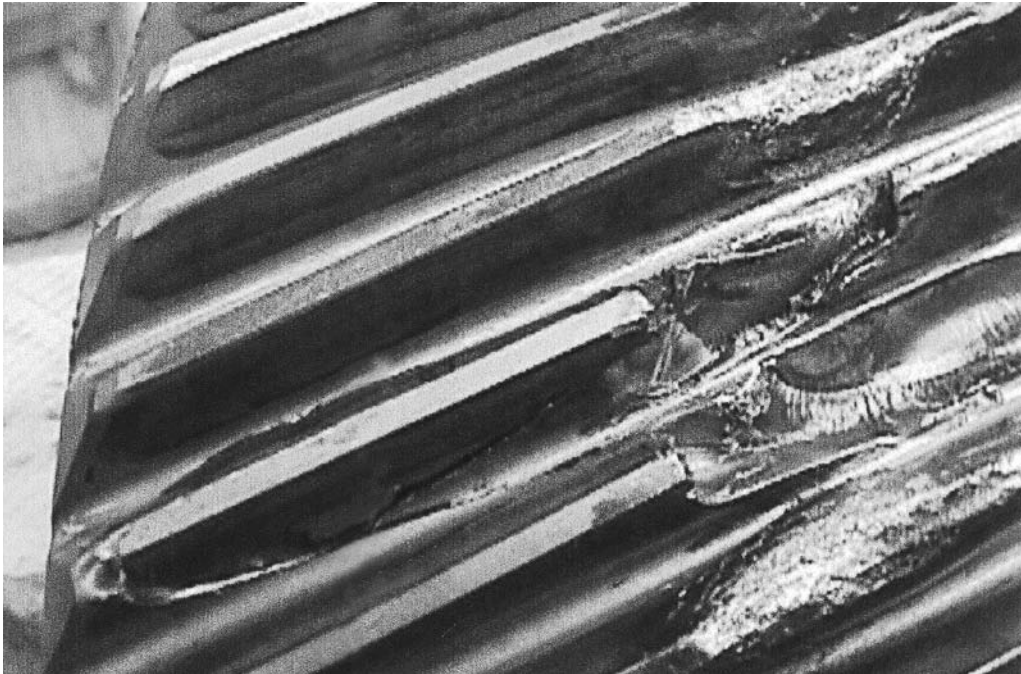
- *Horsepower rating:* 16,500 hp
- *Input speed:* 8,625 rpm
- *Output speed:* 1,500 rpm

The sun pinion and planet gears are nitrided, whereas the ring gear is just through-hardened. The design life of the gears is a minimum of 100,000 h.

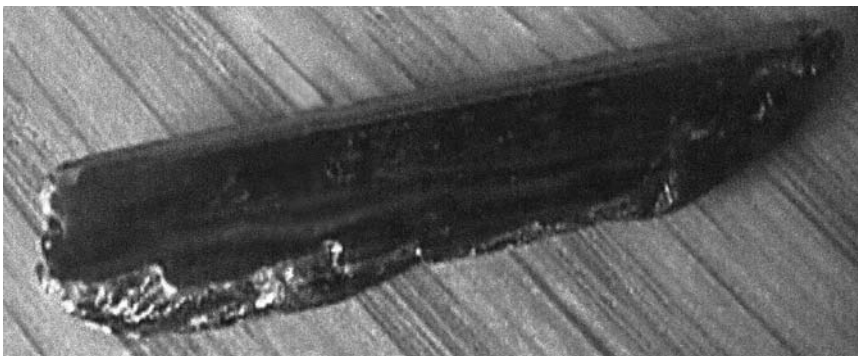
**Failure Incident.** According to a field representative, gearbox failure occurred after 3 h of operation following a scheduled online turbine water wash cycle. In general, all turbines go through a water wash cycle after a few thousand hours of operation. During such a cycle for this turbine, the generator load is brought down to approximately the 8 mW level and then water is injected through the compressor section of the turbine. Following wash, the load is raised to the maximum continuous level of 10.4 mW. After the last wash cycle, high vibration levels of the gearbox were reported just before the gearbox failed. Unfortunately, no data were taken. The gearbox had a total of approximately 16,000 h of service before the failure.

Following this incident, to ensure the failure was not caused by misalignment of equipment or any malfunction of components, such as bearings, couplings, or a shaft, a thorough inspection was conducted. The equipment alignment of the package was found to be within the allowable tolerance. Also, no visible damage of any component was noticed. This led the inspection toward the internal components of the gearbox.

Visual inspection of the disassembled gearbox revealed severe mechanical damage to all gears. The failure was so catastrophic that one complete tooth fell off one of the planet gears and was found at the bottom of the housing. Figure 6.12 shows the damaged planet gear, and Fig. 6.13 shows the severed tooth.



**Fig. 6.12** Overall view of one damaged planet gear



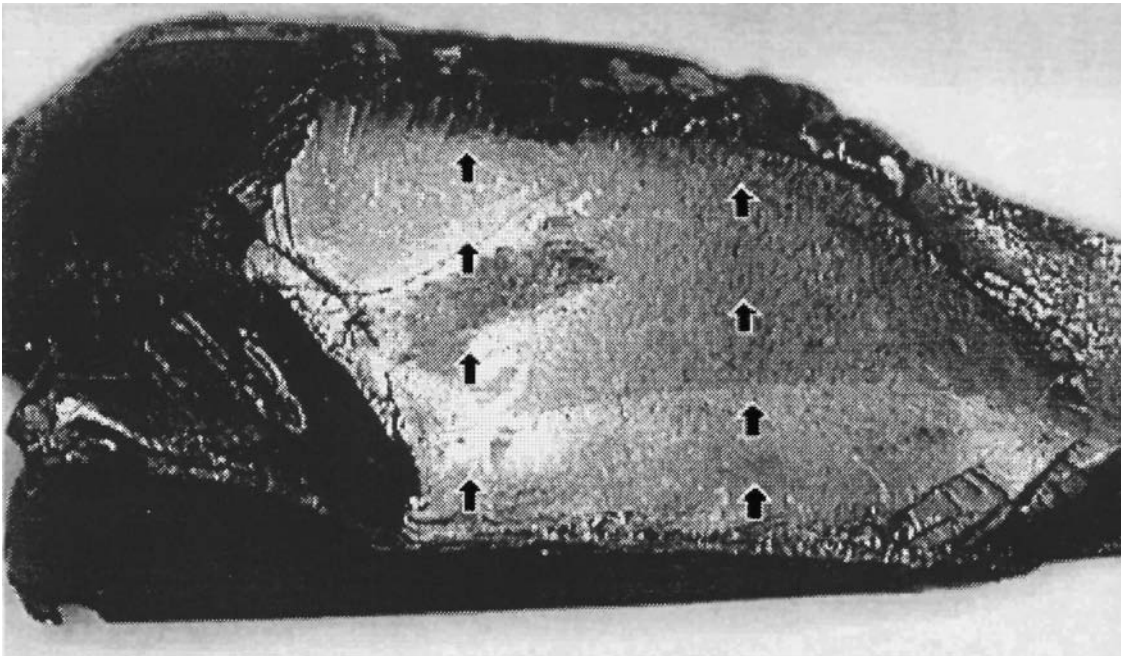
**Fig. 6.13** View of dislocated tooth

Tooth debris was noticed in various gear meshes. No abnormal distress was found on planet sleeve bearings, although the thrust faces of output shaft sleeve bearings were completely wiped out. Also, sealing surfaces of the output shaft and labyrinth seal were found to be burnt.

To determine if there were any discrepancies with the quality of gear material and heat treatment, detailed metallurgical evaluation was carried out with a section from the failed tooth.

**Metallurgical Evaluation.** Examination of the fragmented tooth revealed some well-defined beach marks (Fig. 6.14) suggesting a typical fatigue failure. The tooth segment was also analyzed by an energy-dispersive x-ray spectroscope (EDS) and examined with a scanning electron microscope (SEM). The primary fracture surface was relatively flat and showed well-defined crack growth marks, as illustrated in Fig. 6.15. Features of transgranular fatigue propagation were identified on the fracture surfaces (Fig. 6.16), confirming cracking of the tooth due to a bending-fatigue mechanism. Material certification shows gears were made from European nitriding grade steel (EN-4B), and the chemical composition seems to meet the requirements as shown below:

- C: 0.2–0.28
- Si: 0.10–0.35
- Mn: 0.45 max
- Cr: 3.00–3.50



**Fig. 6.14** Detail view of the received fragment from the primary failed tooth. Arrows indicate the crack propagation direction. 4×

- Mo: 0.45–0.65
- S: 0.025 max
- P: 0.025 max

The case-hardness profile and the effective case depth of teeth were determined by a microhardness tester and are shown in Fig. 6.17. The effective case depth was found to be 0.381 mm (0.015 in.). This satisfies the design requirements for these gears. The core hardness of tooth varied from 25.8 to 27.5 HRC. The desired minimum core hardness is 28 HRC.

**Failure Analysis.** In a mature design of a gearbox as in this case, the failure is believed to be due to the influence of one or more of the following factors:

- Defective gear material or forging
- Improper heat treatment of gears
- Sudden overload beyond design consideration
- High fluctuating load



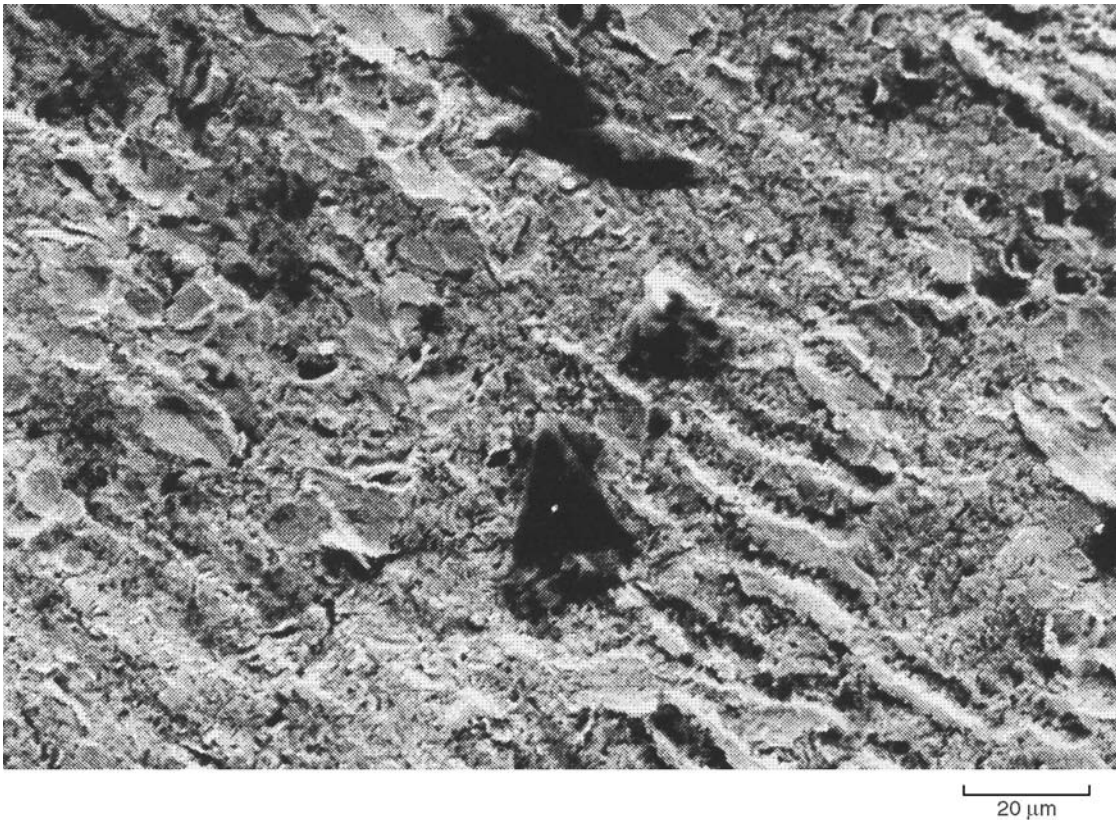
**Fig. 6.15** Scanning electron microscope views of the fracture surfaces of the gear fragment. 100×

In this analysis, failure initiation due to inadequate lubrication is ruled out because no evidence, such as discoloration of tooth or any burn marks, was observed on teeth surfaces. Also, vibration was not believed to be the cause because no abnormal vibration levels were reported while the generator set was running following the turbine wash cycle. Thus, it is justified to assume that gearbox health was reasonably satisfactory for some time before the failure occurred.

In regard to material, the chemical analysis shows an acceptable alloy composition. Also, there were no adverse reports on forging quality, such as banding or grain flow. Therefore, material quality did not seem to play any significant role in the failure mechanism.

Hardness and case depth profile, along with the case microstructure, indicate there was not much discrepancy during heat treatment. Lower core hardness of the planet gears has some influence on the reduction of bending fatigue life but not to the extent as in this case. Because there were no records of any sudden overload, it is believed the major cause of failure was load fluctuation.

Analysis of the generator load spectrum (Fig. 6.18) subsequent to an online engine wash cycle shows quite a bit of load fluctuation—from 4 to 12 mW in a short interval of time (1.5 cycles per second for approxi-



**Fig. 6.16** Scanning electron microscope views of the fracture surfaces of the gear fragment. 500×

mately 25 seconds). Field reports indicate this type of loading occurred many times since the generator set was commissioned. Nobody paid any attention to this loading pattern because it did not represent a real overload condition for the gearbox designed with an overload capacity of four times the nominal rating. That a high fluctuating nominal load could be as damaging as overload to the nitrided gears was simply unknown. Although reduced allowable bending fatigue strength was considered in designing the planet gears for reverse bending, it did not take into account any possible change in the slope of the  $S-N$  curve (damage line) due to the high magnitude of a fluctuating load.

It has been shown (also in Germany in an unpublished work by H. Winter, "Discussion on Life of Nitrided Gears," Dresden, Germany, 1994)) that the slope of  $S-N$  curves for both bending and pitting shifts downward when nitrided gears are subjected to any overload, as illustrated in Fig. 6.6. Conversely, the slope of  $S-N$  curves for carburized and hardened gear steels changes very little, as shown in Fig. 6.5. Therefore, it is certain that the allowable fatigue strengths for both sun and planet

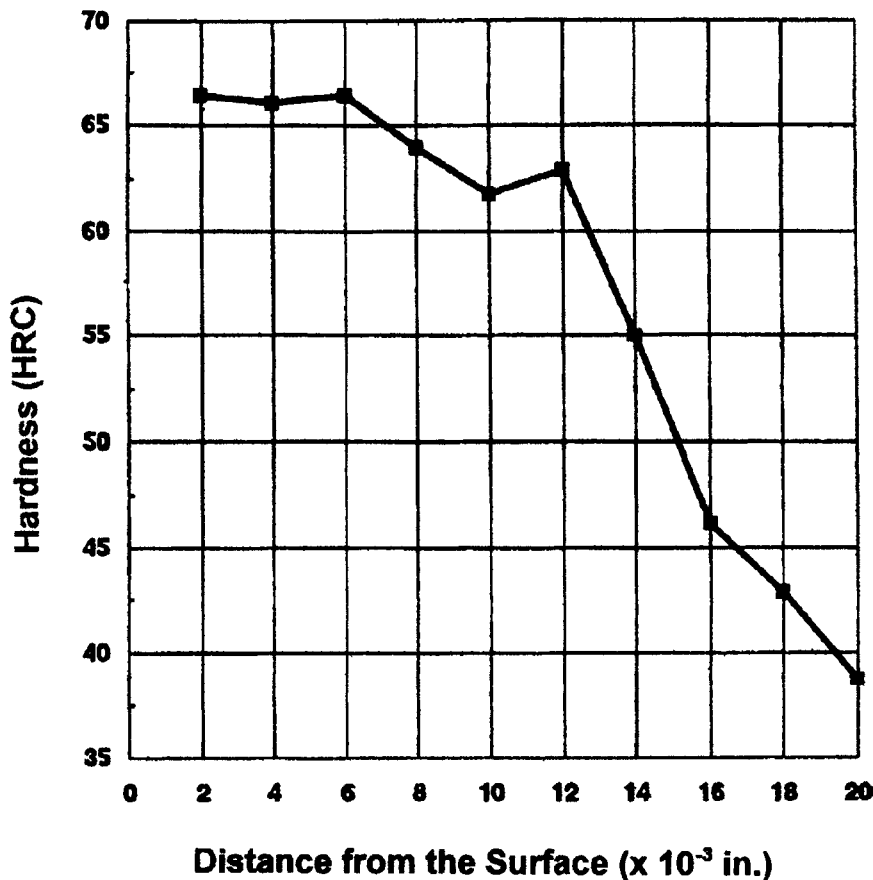
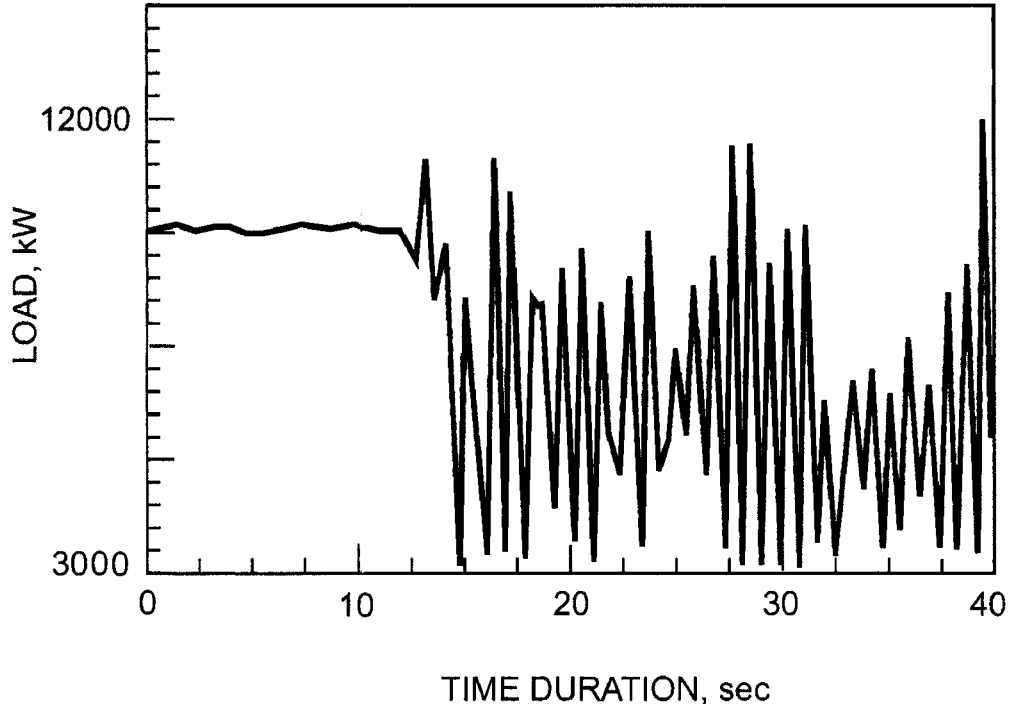


Fig. 6.17 Gear tooth microhardness profile

gears that were nitrided had been reduced due to high fluctuating load. With reduced allowable fatigue strength, one of the planet gears that might have been metallurgically weakest of all failed first. It is believed the fragments of the failed tooth then went into mesh, causing the premature failure of the gearbox.

**Discussion.** The fluctuating load following a turbine water wash cycle was due to some instability in the fuel-control system. This sort of instability and, hence, load fluctuation may be avoided by replacing the online wash of the turbine with a stationary wash procedure. Such an arrangement will definitely improve the life of such gearboxes.

**Conclusions.** The fatigue life of nitrided gears is reduced not only under overload but may also be reduced under highly fluctuating nominal load. The failure due to overload or fluctuating nominal load definitely accelerates with the level of fatigue already induced by previous stress cycles in the nitrided gears. In this case, it is believed that 16,000 h of turbine operation contributed to some extent in the failure of gears. Therefore, it is advisable to consider lower allowable fatigue strengths when designing nitrided gears that are subjected to overload or occasional highly fluctuating load. Also, a cleaner material that meets AMS 2300 or 2304 is recommended in such applications for reliable and high-fatigue strength.



**Fig. 6.18** Fluctuation of generator load after online engine washing

# CHAPTER 7

---

## Modern Nitriding Processes

SEVERAL LIMITATIONS in designing optimum gears with conventional nitriding have led researchers to work on a variety of new and improved nitriding processes. Of these, ion/plasma nitriding offers some excellent improvements and is discussed in some detail in this chapter.

### Ion/Plasma Nitriding Gears

---

Ion nitriding is a vacuum process that takes place in the plasma of high current glow in a vessel. The workpiece, in this case, a gear, forms the cathode, whereas the vessel wall is the anode. The vessel is evacuated prior to nitriding. Gas containing nitrogen is then introduced, and the treatment pressure in the vessel is set to between 0.1 to 10 torr ( $0.13\text{--}13.3 \times 10^2$  Pa). At this point, electric voltage is switched on and a glow discharge takes place; the nitrogen ions thus produced strike the surface of the cathode with high kinetic energy emitting heat that results in a sputtering of the cathode, which atomizes the cathode (gear) surface material. The temperature inside the vessel may vary from 350 to 580 °C (660–1080 °F). The atomized ions then combine with nitrogen ions in the plasma to form iron nitride, which then is deposited as an even iron nitride layer on the cathode. In turn, the iron nitrides are partially broken down on the surface of the cathode, whereby the nitrogen diffuses into the gear material.

As the process continues, the iron from the iron nitrides is partially dusted off in the plasma in front of the workpiece surface. Based on this continual dusting process, the surface of gears being treated is kept active longer. The advantage is that the nitride produced does not immediately act as a diffusion blocker, as in the case of conventional gas nitriding. The case produced by plasma nitriding is thus thicker and free of pores because of the constant ion bombardment. Also, in comparison with the



case produced in gas or liquid nitriding process, ion-nitrided cases are more ductile and more resistant to wear.

In ion nitriding, as in other nitriding processes, the nitrided layer has a diffusion zone and a compound layer. In the diffusion zone, nitrogen diffuses in steel according to classical principles producing a hardened zone by precipitation and solid solution hardening. This zone is detected as a dark etching region below the surface, varying in hardness from the surface to the core. This region is measured as case and may be as deep as 0.9 mm (0.035 in.), depending on the type of steel, nitriding cycle time, and temperature. On the other hand, the compound layer above the diffusion zone known as “white layer” is essentially composed of pure nitrides of iron and is very brittle. In ion nitriding, the white layer is usually below 0.0127 mm (0.0005 in.). It is possible to reduce the thickness of this layer further by controlling the ratio of nitrogen in the nitrogen and hydrogen gas mixture during ion nitriding.

Basically, any type of ferrous gear materials can be ion nitrided. Heat treatable steels are particularly suitable. Table 7.1 shows the results of ion nitriding for some typical gear materials.

To maintain the properties as mentioned in Table 7.1 after ion nitriding, it is essential that there are no traces of rust, paint, or grease on gears because these would prevent nitrogen from being absorbed into the tooth surfaces. Also, it is advisable to have lower arithmetic average ( $R_a$ ) value of these surfaces before nitriding because surface roughness increases in most materials after nitriding due to nitrogen absorption into the surface. The longer the process is, the greater the increase of roughness, although the level of roughness can be returned to its original state by honing or lapping at an additional cost.

Honing or lapping also may be used to remove the white layer. If grinding (not to exceed 0.025 mm, or 0.001 in., stock removal) is used instead, the part shall be stress relieved at 160 to 280 °C (325–540 °F) after grinding. Removal of white layer by chemical means is not advisable. Allowable white layer should not exceed 0.0127 mm (0.0005 in.) and shall be of single phase  $Fe_4N$  composition.

For selective ion nitriding, masking by mechanical means such as plate covers, which act as barriers between the glow of discharge and the part surfaces, is advisable. Masking with copper plating causes sputtering and

**Table 7.1 Results after ion nitriding of common gear materials**

Steel group	Core hardness, HRC	Nitriding temperature, °C (°F)	Surface hardness, 15N scale	Total case depth, mm (in.)	Thickness of white layer, mm $\times 10^{-4}$ (in. $\times 10^{-4}$ )	White layer composition
AISI 9310	28–32	520–550 (970–1020)	89.0	0.305–0.711 (0.012–0.028)	38.10–80.01 (1.50–3.15)	$Fe_4N$
AISI 4130	28–36	510–550 (950–1020)	89.0	0.203–0.660 (0.008–0.026)	38.10–80.01 (1.50–3.15)	$Fe_4N$
AISI 4140	34–38	510–550 (950–1020)	89.0	0.203–0.610 (0.008–0.024)	38.10–80.01 (1.50–3.15)	$Fe_4N$ or none
AISI 4340	38–42	510–550 (950–1020)	89.0	0.254–0.635 (0.010–0.025)	38.10–80.01 (1.50–3.15)	$Fe_4N$ or none
Nitralloy 135M	28–32	510–550 (950–1020)	92.0	0.203–0.508 (0.008–0.020)	20.32–100.33 (0.8–3.95)	$Fe_4N$
Nitralloy N	25–32	510–550 (950–1020)	92.0	0.203–0.508 (0.008–0.020)	25–100.33 (1–3.95)	$Fe_4N$

is not advisable. As an alternate to masking, parts may be nitrided all over first and then the surfaces ground where case is not desired or required.

Dimensional growth is minimal during ion nitriding. The growth is dependent on the quantity of nitrogen deposited. High-alloy steels take up more nitrogen than those with a low-alloy content. Hence, there is more growth of high-alloy steel gears. In case of insufficiently annealed and normalized steels, the annealing effect of ion nitriding may cause disintegration of the stable retained austenite, leading to a disproportional growth and distortion. Also, ion nitriding can cause a decrease in volume in gears made of martensitic steels. As in other heat treat processes, dimensional change of gears is better determined by a preproduction run. In the absence of such data, a growth of 0.025 mm per 0.127 mm (0.001 in. per 0.005 in.) diffusion depth may be considered for most gear steels.

In ion nitriding, the discharge parameters of voltage and current determine the supply of active ions, and that nitriding potential of the low-pressure atmosphere in the chamber is essentially independent of the temperature of the charge, unlike conventional gas nitriding. This capability results in a number of unique advantages; for example, materials that would lose their core strength under conventional nitriding conditions can be ion nitrided because the prerequisite for maintaining the core strength is that nitriding temperature be below the temper temperature. This also reduces distortion considerably.

**Ion-Nitriding Time and Case Depth.** For the same processing time, case depth attained with ion nitriding is higher than gas nitriding. Figure 7.1 shows the results of case depth versus treatment time for AISI 4140 steel ion nitrided at 510 °C (950 °F) and gas nitrided at 525 °C (975 °F). Similar results also are achieved with Nitralloy 135M steel. As in gas nitriding, higher case depth is obtained with AISI 4140 steel than with Nitralloy 135M. But Nitralloy 135M produces higher surface hardness. Similar to gas nitriding, time for ion nitriding varies with case depths and material. Figure 7.2 depicts time required for different case depths and two gear materials.

**Hardness and Case Depth.** Case-hardened samples of AISI 4140 and 4340 steels produced by ion-nitriding process showed encouraging results as tabulated in Table 7.2. The major shortcoming of earlier ion-nitriding processes was the large variation in case depth from area to area of teeth.

**Table 7.2 Summary of metallographic measurements**

Measurement	4140 Sample	4340 Sample	Requirement
Case depth, mm (in.)	Over 0.889 (over 0.035)	0.508 (0.020)	0.51 (0.02)
Surface hardness, HK	690	604	540 min.
Core hardness, HRC	36	35	32–38
Grain size (ASTM)	No. 7	No. 6	No. 5 or finer
White layer depth, mm (in.)	0.0025 (0.0001)	0.0051 (0.0002)	None

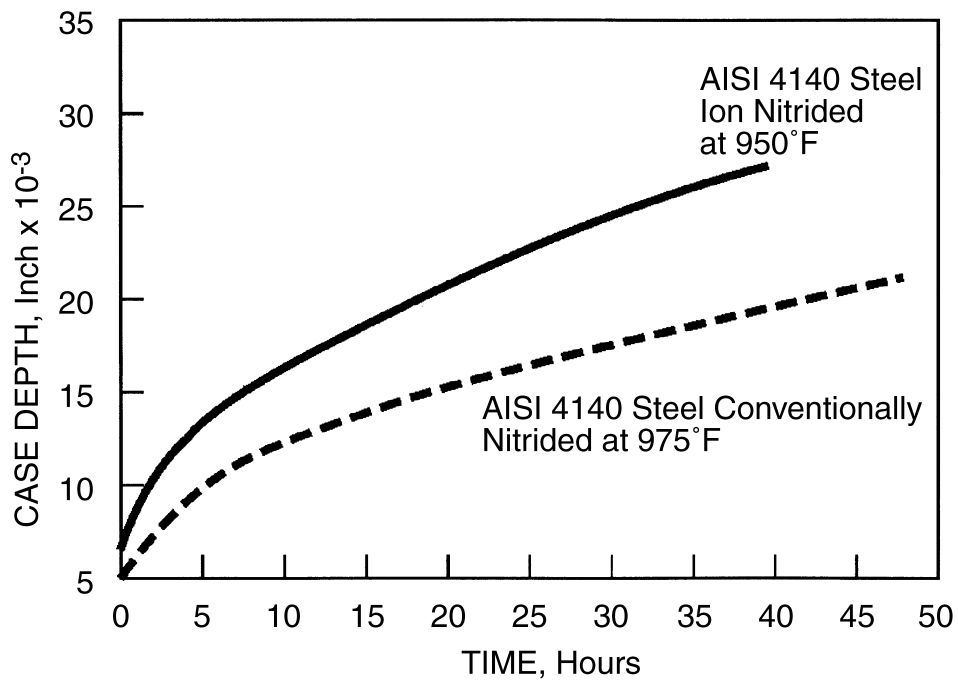


Fig. 7.1 Comparison of case depth vs. process time for ion and conventional nitriding

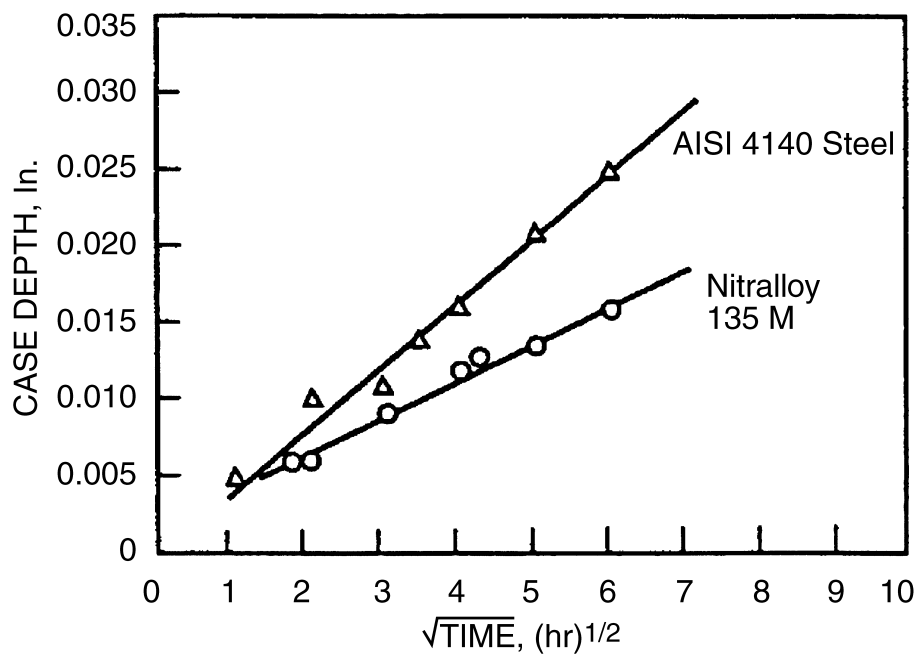
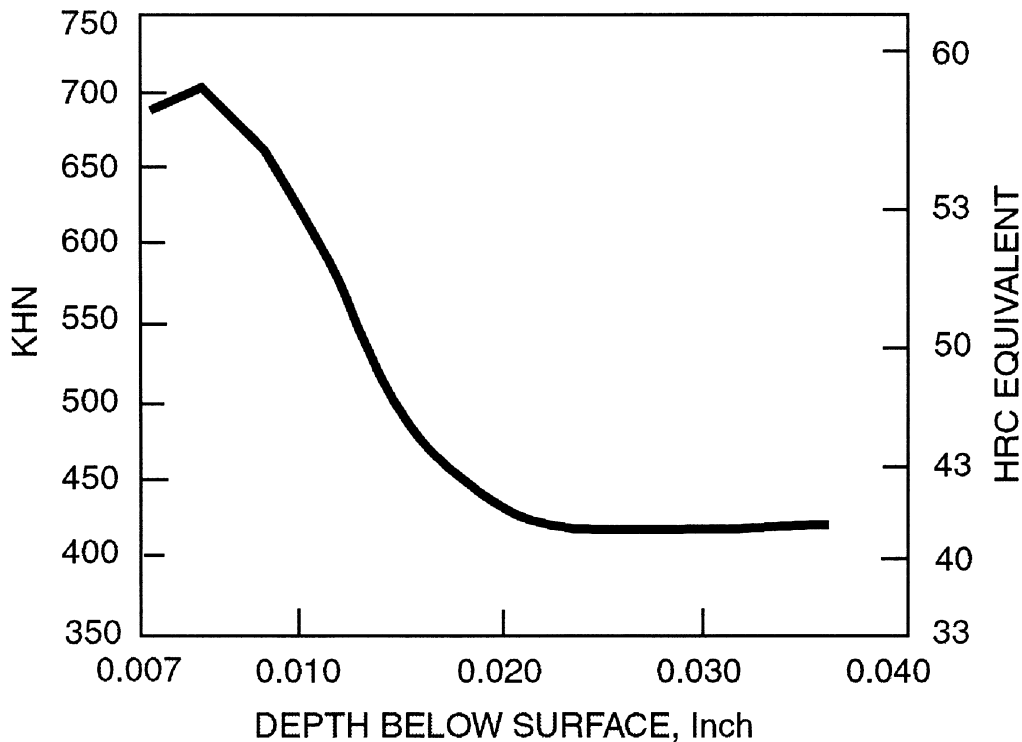


Fig. 7.2 Case depth vs. square root of ion-nitriding time for two materials

However, the current improved process offers fairly uniform case depths. Some typical microhardness traverses for gear tooth made of AISI 4140 and 4340 steels are illustrated in Fig. 7.3 and 7.4, respectively.

**Improved Case Property.** Ion-nitrided surfaces, especially with high-alloy steels, show comparatively good ductility. This characteristic is due to the ability to closely control the amount and type of white layer. High ductility results in high fatigue properties.

**Distortion.** Because gears are ion nitrided under vacuum, only the stresses originating from the thermal and preliminary treatments lead to distortion. For this reason, to minimize distortion, gears are stress-free annealed before ion nitriding. The temperature of the stress relief is maintained at least 25 °C (75 °F) over the ion-nitriding temperature. Also, slower cooling after the stress relief is recommended. A second stress relief is sometimes beneficial after rough machining. If done properly, the distortion is expected to be minimal. Should the core hardness be diminished through stress relieving to a value too low, an alternate material should be used. Table 7.3 presents comparative distortion ratings of some ion-nitriding materials.



**Fig. 7.3** Microhardness traverse of AISI 4140 steel gear sample

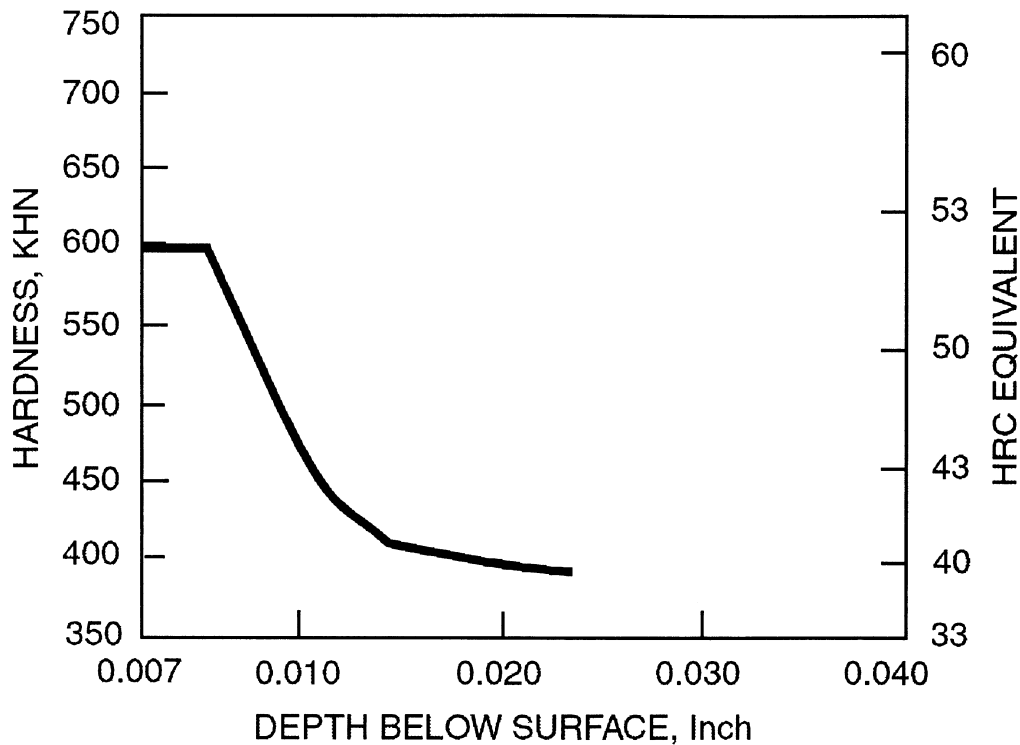


Fig. 7.4 Microhardness traverse of AISI 4340 steel gear sample

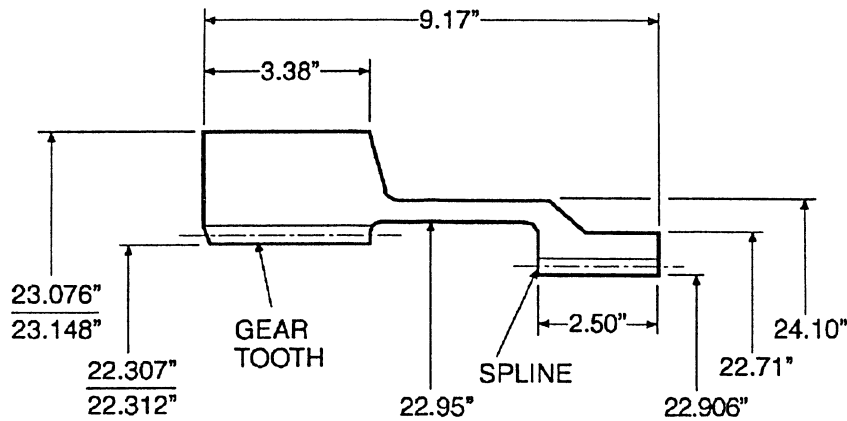
Table 7.3 Distortion ratings of some ion-nitriding materials

Material	AMS specification	AMS quality	Nitriding temperature, °C (°F)	Hardness, HRC		Distortion rating
				Case	Core	
AISI 9310/9315	6265	2300/2304	520–550 (970–1020)	50/58	28/32	Good
AISI 4340	6414	2300/2304	510–550 (950–1020)	54/58	38/42	Good
Nitralloy 135M	6471	2300/2304	510–550 (950–1020)	60/62	28/32	Good
Nitralloy N	6475	2300/2304	510–550 (950–1020)	60/62	26/32	Good

## Case History: Application of Ion Nitriding to an Internal Ring Gear of an Epicyclic Gearbox

A test was carried out to determine the suitability of ion nitriding an internal ring gear used in a star epicyclic gearbox. Figure 7.5 shows the dimensions of the ring gear. The design requires the surface hardness of teeth to be 55 HRC minimum with core hardness of 30 to 36 HRC. The effective case depth is to be 0.43 to 0.61 mm (0.017–0.024 in.). The material selected is AISI 4340, and the quality of the finished gear teeth is AGMA class 10. Ion nitriding of teeth was considered for minimum white layer on teeth and low distortion.

**Process and Results.** To minimize distortion after nitriding, the forgings were first properly normalized before any machining. After



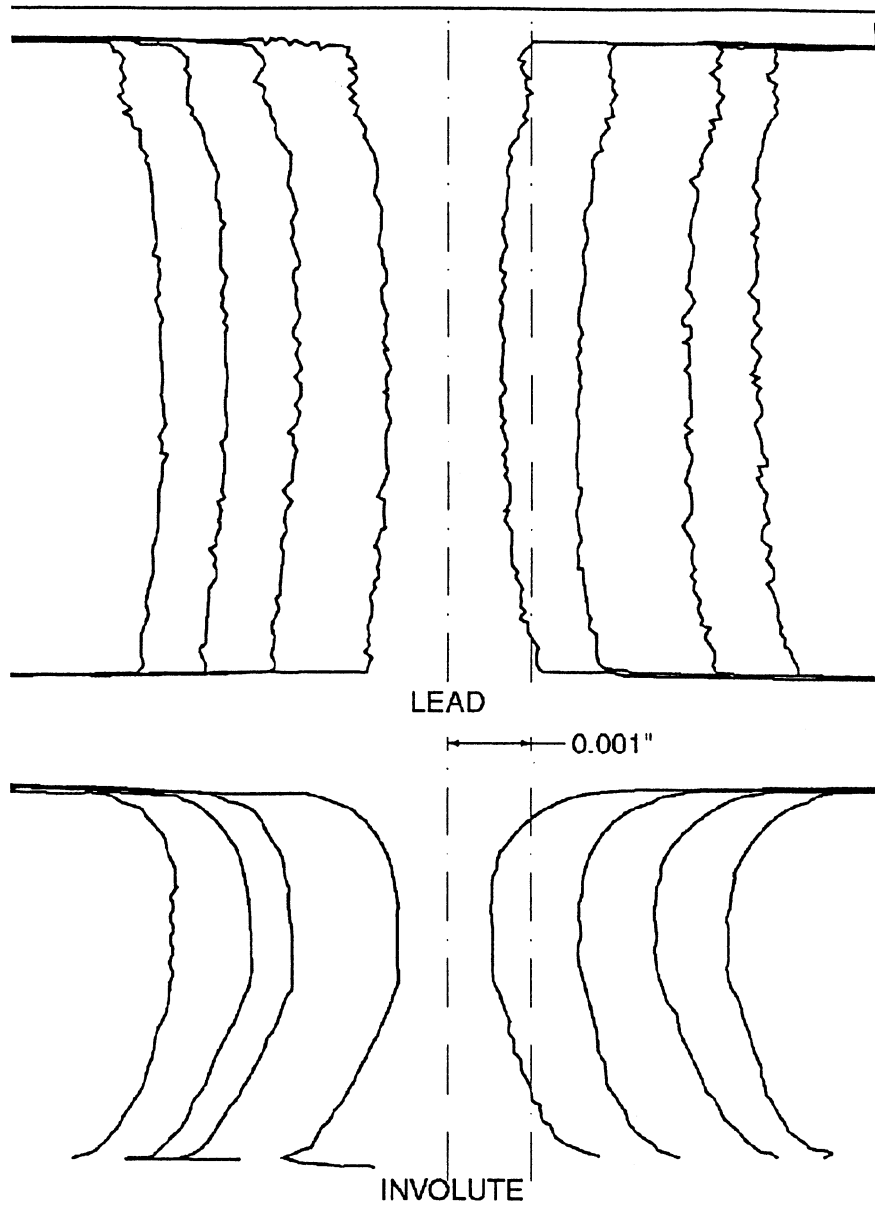
No. of Teeth: 125  
 DP: 5.6233  
 PD: 22.7186 ref  
 PA: 25°  
 Helix Angle: 10° RH  
 Material: AISI 4340

**Fig. 7.5** Basic dimensions of ring gear

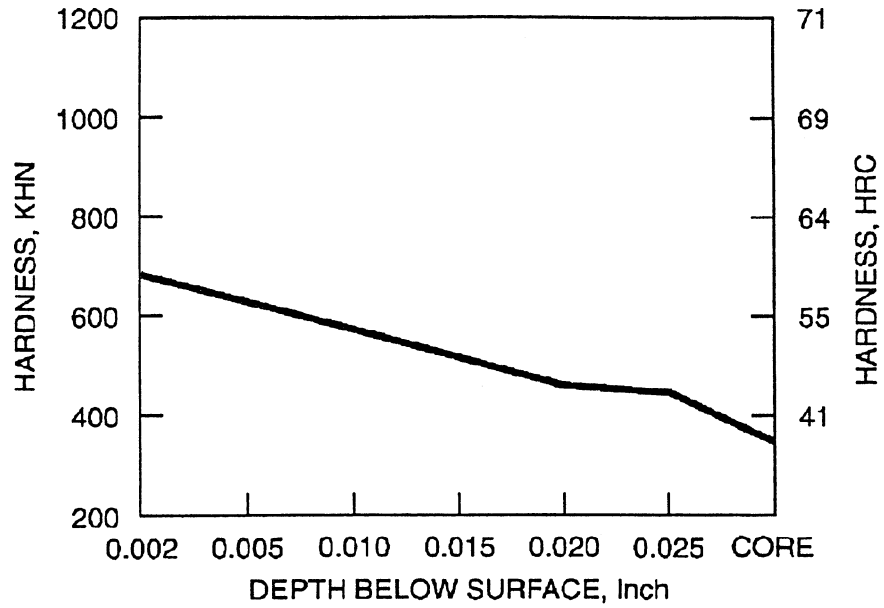
shaping the teeth, the gears were stress relieved and shaved to AGMA class 11. Typical involute and lead charts are depicted in Fig. 7.6. Areas that did not require nitriding were masked by mechanical means. The gears were then ion nitrided at 480 °C (900 °F) for 18.5 h and furnace cooled. The case depth, case and core hardness, and depth of white layer of the sample coupon were measured. Hardness profiles of teeth at pitch diameter (PD) and root radius exceeded design requirement. The hardness gradients of these profiles were far superior to any gas-nitrided gears as illustrated in Fig. 7.7 and 7.8. The white layer was measured as 0.005 mm (0.0002 in.). No evidence of microcracks, heavy grain boundary nitrides, or decarburization was observed at the case. The core microstructure was essentially tempered martensite. Historically, the major shortcoming of ion-nitrided cases has been the large variation in case depth from area to area. However, case depth on the sample was fairly uniform. Finally, lead and involute charts were taken of the finished gears and are illustrated in Fig. 7.9. Also measured were PD, runout, and index error of the teeth. All met AGMA class 10 requirements. In one batch, ring gears were not properly normalized, resulting in some minor distortion of leads and involutes. This distortion is illustrated in Fig. 7.10.

**Controlled Nitride Process.** Recently, a company in Montreal, Canada developed an advanced nitrogen diffusion technology. The

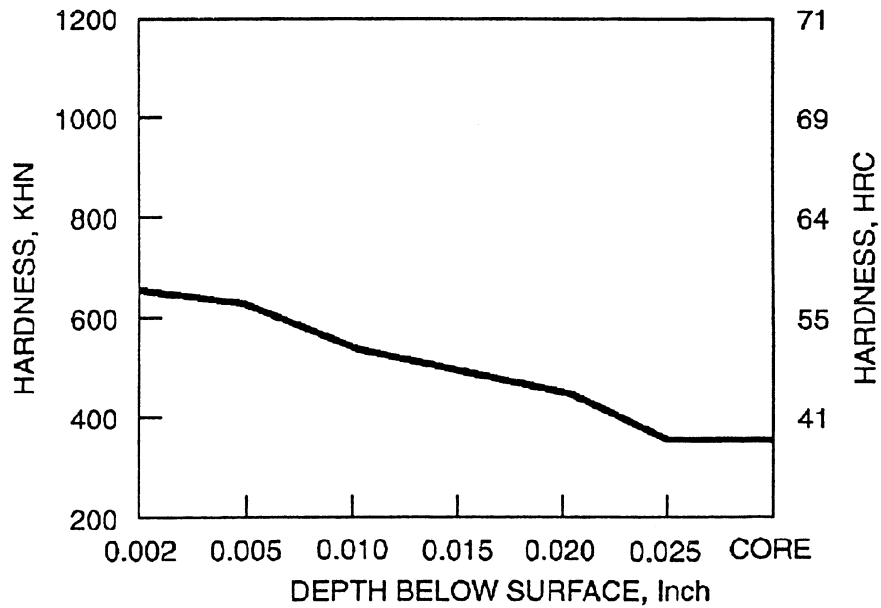
principal characteristic of this process is that the regulated nitriding potential of the furnace atmosphere, expressed as the ratio of  $\text{NH}_3$  and  $\text{H}_2$  partial pressures, is related to the coefficient of nitridability of the particular steel.



**Fig. 7.6** Involutes and leads of teeth before nitriding



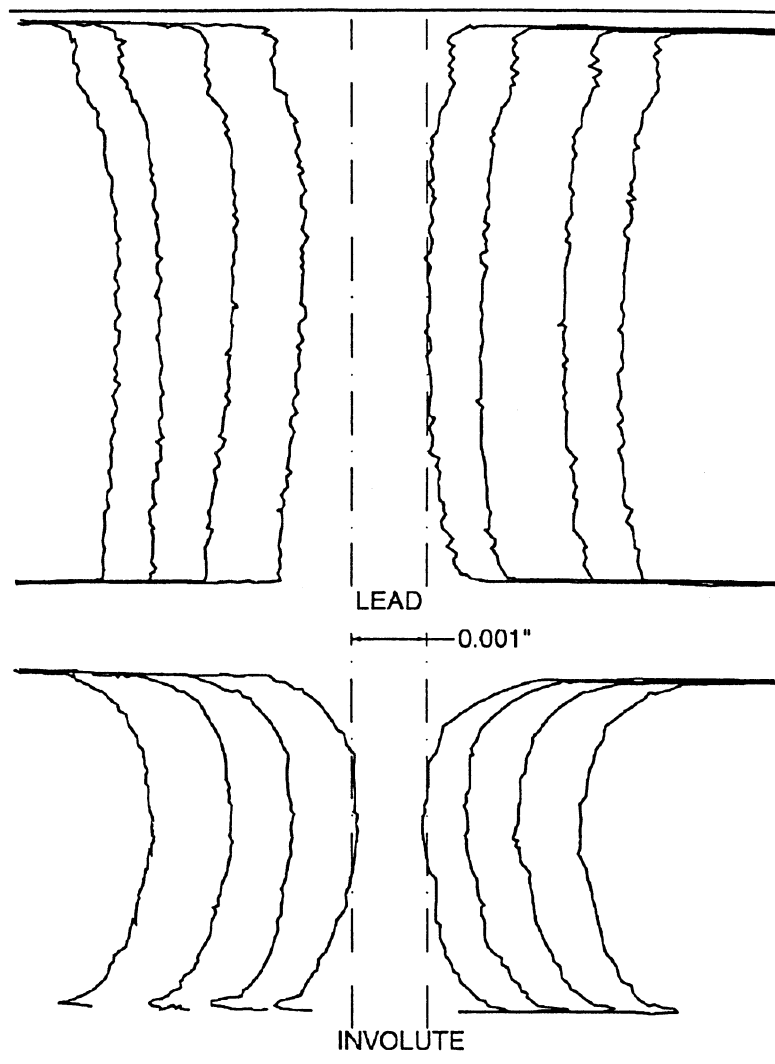
**Fig. 7.7** Hardness profile of ring gear tooth at pitch diameter (PD)



**Fig. 7.8** Hardness profile of ring gear tooth at root radius



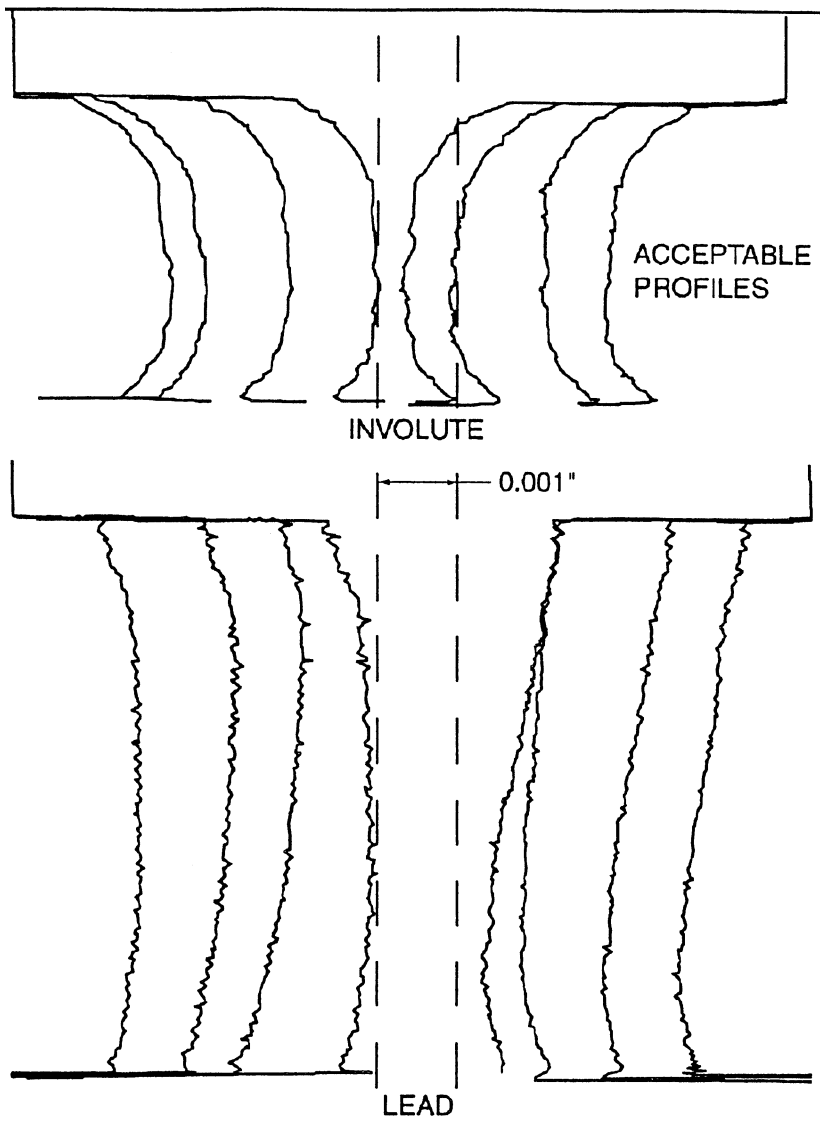
To optimize the case properties and process times, the nitriding potential is programmed for a certain potential during the treatment, depending on the type of steel. Automatic regulation of the nitriding potential results in dramatic improvement in the case quality. This also means a total control of the white layer thickness with restricted nitrogen concentration and regulated phase composition as well as the diffusion-zone profile. The white layer produced (0.0127 mm, or 0.0005 in., maximum) has a high load-bearing capacity and does not crack or spall in



**Fig. 7.9** Involute and lead profiles after ion nitriding

service. For certain applications, the formation of a white layer can be entirely suppressed.

The company also claimed the process effectively eliminated distortions caused by uncontrollable white layer growth, grain boundary networks, and a high nitrogen concentration.



**Fig. 7.10** Distorted leads due to improper normalizing

# CHAPTER 8

---

---

## Carbonitriding Gears

Carbonitriding is defined as a process in which carbon and alloy steel gears are held at a temperature above the transformation range in a gaseous atmosphere of such composition that steel absorbs carbon and nitrogen simultaneously and then are cooled at a specific rate to room temperature that produces the desired properties. Carbonitriding is generally regarded as a modified gas carburizing process, rather than a form of nitriding. Nitrogen has an effect similar to carbon on the martensitic structure.

Carbonitriding is performed in a closed furnace chamber with an atmosphere enriched with gaseous compound of carbon and nitrogen. Many types of gas are used. Common practice is to use an endothermic gas, such as natural gas, as a carrier for the ammonia and hydrocarbons. The process primarily imparts a hard, wear-resistant case. A carbonitrided case has better hardenability than a carburized case. Also, the presence of  $N_2$  in the case, as in nitriding, increases its hardness. Most carbonitriding is done between 770 and 890 °C (1425 and 1625 °F) for gears to be liquid quenched and between 650 and 790 °C (1200 and 1450 °F) for gears not requiring liquid quench.

The addition of nitrogen has three important effects:

- It inhibits the diffusion of carbon, which favors production of a shallow case.
- It enhances hardenability, which favors attainment of a very hard case.
- Nitrides are formed, increasing the surface hardness further.

A case consisting of all nitrogen will have the highest hardenability and the highest resistance to tempering but will not be as hard as an all-carbon case. For an optimum carbonitrided case, just sufficient nitrogen should be used that gives the required hardenability. The balance should be carbon.

## Case Depth in Carbonitriding

---

The process can produce case depth between 0.076 and 0.76 mm (0.003 and 0.030 in.). For gears that are subjected to high compressive or bending stress, a case depth between 0.64 and 0.76 mm (0.025 and 0.030 in.) frequently is used. Medium-carbon steels with core hardness of 35 HRC to 40 HRC require less case depth than steels with core hardness of 30 HRC or below. Carbonitriding, because of the lower furnace temperatures employed, is capable of producing a more uniform case depth than gas carburizing.

## Measurement of Case Depth

---

Total case depth or effective case depth is measured the same way as with carburized gears. In general, it is easy to distinguish case and core microstructures in a carbonitrided gear, particularly when the case is thin and is produced at a low temperature. However, similar difficulty is experienced as with carburizing in distinguishing case and core for deep cases obtained at high temperatures. Cases shallower than 0.25 mm (0.010 in.) generally are specified as total case depth.

## Materials

---

All carburizing grade materials can be carbonitrided. Gears commonly carbonitrided include steels of AISI 4100, 4300, and 8600 series with carbon contents up to about 0.25%. In addition, many steels in these series with a carbon range of 0.35 to 0.50% are carbonitrided when a combination of a reasonably tough core and a hard surface is required.

## Distortion

---

Distortion in carbonitrided gears is far less than that of carburized gears because of lower process temperatures and shorter time cycles. Nevertheless, it is more than any nitriding process. But one major advantage of carbonitriding is that the hardenability of the case is significantly greater than carburizing or nitriding process. This permits in many cases to finish grind teeth (0.076 to 0.102 mm, or 0.003 to 0.004 in., stock removal) without any significant loss of hardness.

## Applications

---

Carbonitriding is limited to shallower cases for fine pitch gearing used primarily in aerospace applications. Deep case depths require prohibitive time cycles. The carbonitrided case has better wear and temper resistance than a carburized case. For many applications, carbonitriding of low-alloy steels provides case properties equivalent to those obtained in gas carburized high-alloy steels. But the core often has low hardness. This is why the process is generally applied to gears of low-duty cycle.

The major advantage of carbonitriding is low distortion compared with carburizing.

# CHAPTER 9

---

---

## Induction Hardening Gears

GEARS NEED TO BE HARDENED occasionally only at the surface without altering the chemical composition of the surface layers. It is possible to do so by very rapid heating with electrical induction for a short period, thus conditioning the surface for hardening by quenching, provided the steel used contains sufficient carbon to respond to hardening. Because the heating is done by electrical induction, the process is known as induction hardening.

In this process, rapid heating is generated by electromagnetic induction when a high-frequency current is passed through a coil surrounding a gear. The depth to which the heated zone extends depends on the frequency of the current and on the duration of the heating cycle. Because of an electrical phenomenon called skin effect, the depth of the heated area is inversely proportional to the frequency used. It means the finer the pitch of gear tooth is, the higher the frequency of current needed will be. The time required to heat the surface layers to above the material transformation range is surprisingly brief, a matter of a few seconds. Selective heating and, therefore, hardening, is accomplished by suitable design of the coils or inductor blocks. At the end of the heating cycle, the steel usually is quenched by water jets passing through the inductor coils. Precise methods for controlling the operation, such as the rate of energy input, duration of heating, and rate of cooling, are thus necessary. These features are incorporated in induction hardening equipment, which usually is operated entirely automatically.

Induction hardening employs a wide variety of inductors ranging from coiled copper tubing to forms machined from solid copper combined with laminated materials to achieve the required induced electrical currents. Coarser pitch teeth (below 20 DP) generally require inductors powered by medium-frequency motor generator sets or solid-state units. Finer-pitch gearing uses encircling coils with power provided by high-frequency vacuum tube units. Wide-faced gearing is heated by scanning-type equipment, while more limited areas can be heated by stationary

inductors. Parts are rotated when encircling coils are used. Induction heating depth and pattern are controlled by frequency, power density, shape of the inductor, workpiece geometry, and workpiece area being heated.

Quenching after induction heating can be integral with the heat source by use of a separate following spray or by using an immersion quench tank. Oil, water, or polymer solutions can be used, in addition to air, depending on hardenability of the steel and hardening requirements.

## Materials

---

A wide variety of materials can be induction hardened, including (cast and wrought) carbon and alloy steels, martensitic stainless steels, and ductile, malleable, and gray cast irons. Generally, steels with carbon content of approximately 0.35 to 0.50% are suitable for induction hardening. Alloy steels with more than 0.5% carbon are susceptible to cracking. The higher the alloy content with high carbon is, the greater the tendency to crack will be. Some of the common gear materials that offer acceptable case and core properties after induction hardening are AISI 1040, AISI 1050, AISI 4140, AISI 4340, and AISI 5150 steels.

Selection of the material condition (hot rolled, cold rolled) can affect the magnitude and repeatability of induction hardening. Hot-rolled materials exhibit more dimensional change and variation than cold drawn because of densification of material from cold working. A quench and tempered material condition before heat treatment, however, provides the best hardening response and most repeatable distortion.

## Pre-Heat Treatment

---

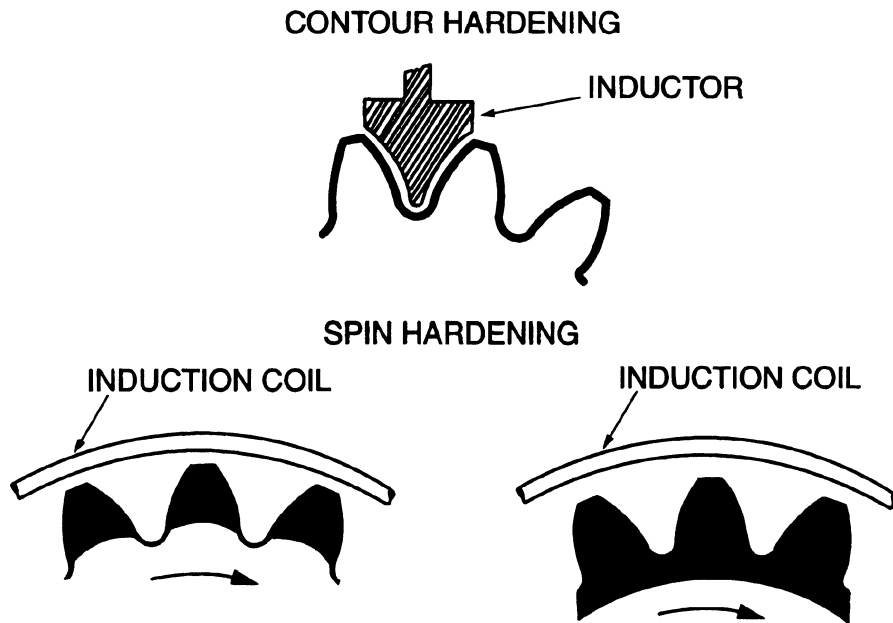
For more consistent results, it is recommended that coarser pitch gears of leaner alloy steels receive a quench and temper pretreatment, for example, AISI 4140 steel with teeth coarser than 4 DP.

Both carbon and alloy steels with normalized or annealed structures can be induction hardened. These structures do, however, require longer heating cycles and a more severe quench, which increase the chance of cracking. The annealed structure alone is the least receptive to induction hardening.

## Hardening Patterns

---

There are two basic methods of induction hardening gears: spin hardening and tooth-to-tooth, or contour hardening. Figure 9.1 shows variations of these processes and the resultant hardening patterns. In spin



**Fig. 9.1** Variations in hardening patterns obtainable on gear teeth by induction hardening

hardening that uses a circular inductor, the teeth are hardened from the tips downward. While such a pattern may be acceptable for splines and some gearing, heavily loaded gears need a hardness pattern that is more like a carburized case. This is achieved with contour hardening.

The spin or induction coil method is generally limited to gears of approximately 5 DP and finer. The maximum diameter and face width of gears capable of being hardened by this method are determined by the area of gear outside diameter and kW capacity of the equipment. Long slender parts can be induction hardened with lower kW capacity equipment by having coils scan the length of part while it is rotating in the coil.

Contour hardening can be applied to almost any tooth size with appropriate supporting equipment and kW capacity. However, for gears of approximately 16 DP and finer, this method does not produce satisfactory results. In such cases, an induction coil method is recommended.

## Heating with Induction

Accurate heating to the proper surface temperature is a critical step. Inductor design, heat input, and cycle time must be closely controlled. Underheating results in less than specified hardness and case depth. Overheating can result in cracking. For effective heating, current frequencies used for different DP of gears are shown in Table 9.1.



**Table 9.1 Recommended current frequencies**

Diametral pitch (DP)	Frequency, kHz
20	500–1000
10	300–500
8	300–500
6	10–500
4	6–10
2	6–10

---

## Quenching

---

Heat must be removed quickly and uniformly to obtain desired surface hardness. The quenchant should be such that it produces acceptable as-quenched hardness, yet minimize cracking. Quenchants used are water, soluble oil, polymer, oil, and air.

Parts heated in an induction coil usually are quenched in an integral quench ring or in an agitated quench media. Contour hardening is equipped with an integral quench following the inductor, or the gear may be submerged in a quench media.

---

## Tempering

---

Tempering is performed only when specified. However, judgment should be exercised before omitting tempering. It is a good practice to temper after quenching to increase toughness and reduce residual stress and crack susceptibility. Tempering should be done for sufficient time to ensure hardened teeth reach the specified tempering temperature.

---

## Surface Hardness and Case Depth

---

Frequency and power density of electrical power and its time duration govern the depth of heating, which eventually controls the surface hardness and case depth that can be achieved after induction hardening. Surface hardness is primarily a function of carbon content. It also depends on alloy content, heating time, mass of the gear, and quenching considerations. Hardness achieved is generally between 53 and 55 HRC. The core hardness is developed by quenching and tempering prior to induction hardening. As already discussed, high frequency of current can control heat to a shallow depth on the tooth surfaces, whereas low frequencies produce greater depth of heat penetration. For example, a case depth of 0.254 mm (0.010 in.) can be produced with a frequency between 100 kHz and 1 MHz.

For larger case depths, frequencies between 3 and 25 kHz are used. Table 9.2 shows approximate case depths that are normally achieved with the induction hardening process.

In an induction-hardened tooth that requires high bending strength, it is necessary to get a reasonable hardness depth at the root fillet. Table 9.3 shows how much is needed for different size gear teeth.

Even though the correct hardness depth is obtained in the root region, it still is difficult to obtain high bending strength with induction-hardened gears made of any alloy steel. Therefore, a proper material selection is critical. Another drawback of induction hardening is residual tensile stress. With a clever development program, it is usually possible to work on an induction-hardening cycle so that the timing of the heating, the delay before quench, and the quenching are such that gears are free from dangerous residual tensile stresses.

**Effective Case Depth.** Effective case depth for induction-hardened gears normally is defined as the distance below the surface at the 0.5 tooth height where hardness drops 10 HRC points below the surface (Fig. 9.2). In case a tooth is through hardened (finer DP gears), effective case depth does not apply. When root is to be hardened, depth of case at the root may be separately specified.

**Core Hardness of Tooth and Fatigue Strength.** For every gear material, there is an optimum core hardness for maximum fatigue strength, provided the tooth is not through hardened. As the size of tooth decreases (higher DP), teeth tend to become through hardened. In case of induction-hardened teeth, through hardening takes place for tooth size above 10 DP, meaning allowable fatigue strength for induction-hardened gears above 10 DP needs to be reduced.

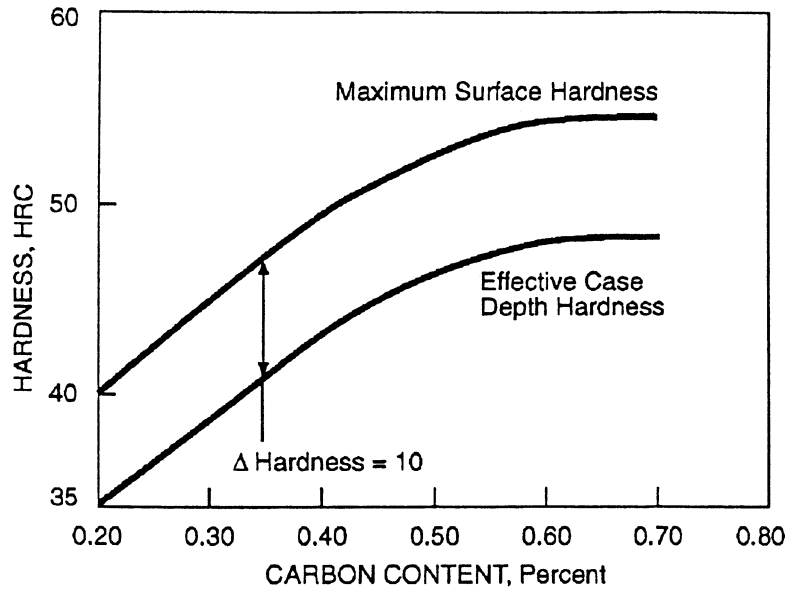
**Table 9.2 Current frequency versus case depth**

Frequency, kHz	Approximate case depth, mm (in.)
3	3.81 (0.150)
10	1.52–2 (0.060–0.080)
500	0.51–1 (0.02–0.04)
1000	0.25–0.51 (0.01–0.02)

**Table 9.3 Recommended depth of hardness in root region for induction-hardened teeth**

Diametral pitch (DP)	Hardness depth, mm (in.)	Frequency, kHz
20	0.25–1 (0.010–0.040)	500–1000
16	0.38–1.52 (0.015–0.060)	500–1000
10	0.51–2.54 (0.020–0.100)	300–500
8	0.76–3.18 (0.030–0.125)	300–500
6	1.14–3.81 (0.045–0.150)	100–300
4	1.52–4.45 (0.060–0.175)	6–10

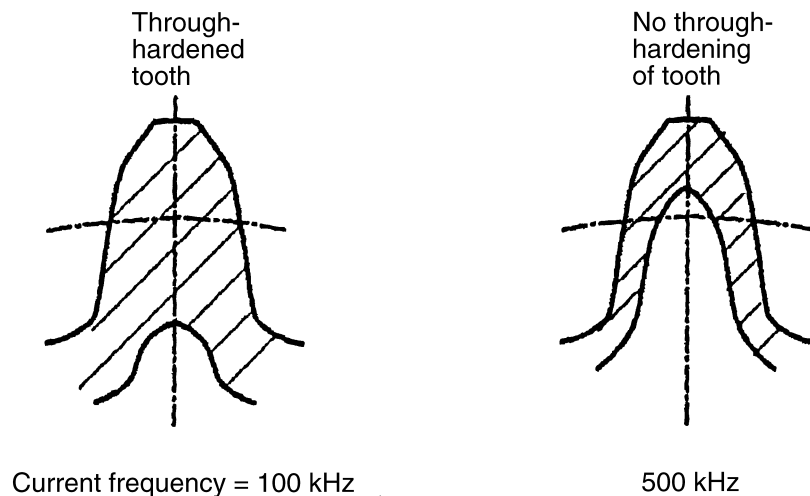
Depth reading taken at the center of root fillet.



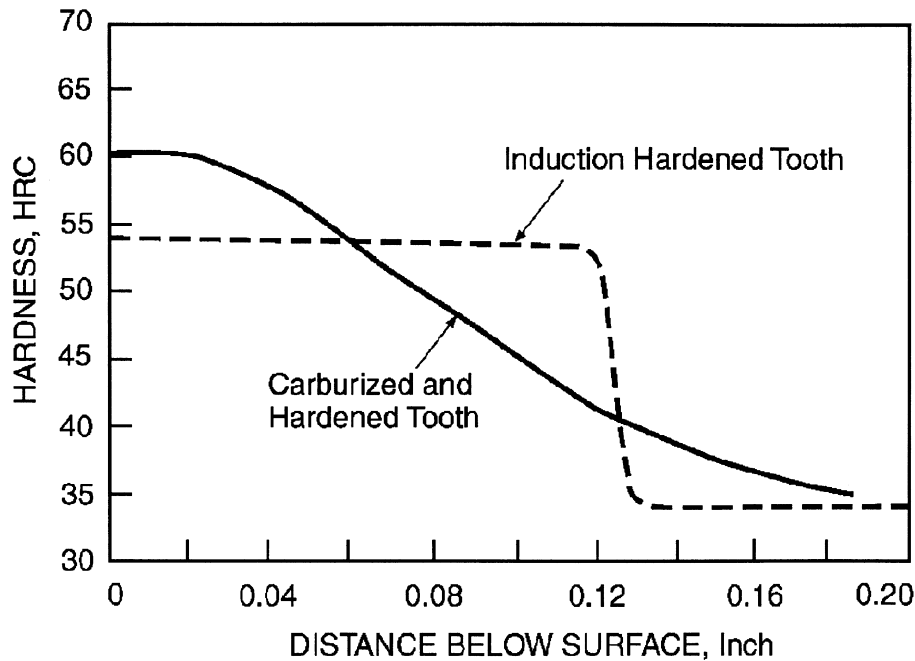
**Fig. 9.2** Recommended maximum surface hardness and effective case depth hardness vs. carbon percent for induction-hardened gears

## Induction Hardening Problems

It is quite difficult to obtain uniform case depth on a gear tooth with induction hardening. Typical case profiles of induction-hardened teeth are shown in Fig. 9.3. Furthermore, it also is difficult to obtain a reasonable depth of hardness at the center of root fillet. This results in lower bending strength compared with a carburized and hardened gear tooth. Further-



**Fig. 9.3** Case depth profiles at different current frequency



**Fig. 9.4** Comparison of hardness gradients—induction-hardened and carburized gears

more, the maximum attainable surface hardness with induction hardening is about 55 HRC, which limits the durability of gears.

Another problem with an induction-hardened gear is residual stress in the case/core interface. In this region, there are high residual stresses due to drastic differences of the case and core microstructures and the fact that the transition occurs in a very short distance, as illustrated in Fig. 9.4. This figure also shows the differences in case hardness gradients for induction-hardened and carburized gear teeth. If the induction hardening process is not properly controlled, the case/core interface area could be susceptible to cracking.

In any case, considering all the merits and demerits, induction hardening is a viable gear heat treat process. For successful use of the process, it is necessary to go through several developmental steps similar to other heat treat processes.

**Heat Treat Distortion.** As with other heat treat processes, there is some distortion of gears after induction hardening. Hot-rolled materials exhibit more dimensional change and variation than cold-drawn materials that are subjected to densification due to cold working. A quench and tempered material condition or pre-heat treatment, however, provides the best hardening response and most repeatable distortion. Table 9.4 shows

**Table 9.4 Distortion ratings of some induction-hardening materials**

Material (AISI)	AMS specification	AMS quality	Hardness, HRC		Distortion rating(a)
			Case	Core	
1040	...	2300/2304	54	30	Good
1050	...	2300/2304	54	30	Good
4140	6382	2300/2304	55	40	Good
4340	6414	2300/2304	55	40	Poor
5140	...	2300/2304	55	40	Poor

Note: Alloy steels with 0.5% carbon and above are susceptible to cracking. (a) Compared with carburizing and hardening

comparative ratings of some common induction-hardening type materials. In general, after induction hardening, the quality level of gears does not go down by more than one AGMA quality level. Thus, in most applications, induction-hardened gears do not require any post-heat-treat finishing except for high-speed applications (pitch line velocity above 50.8 m/s, or 10,000 ft/min); mating gears sometimes are lapped together.

## Applications

Induction hardening has been used successfully on most gear types (e.g., spur, helical, bevel, etc.). This process is used when gear teeth require high surface hardness, but size or configuration does not lend itself to carburizing and quenching the entire part. The process also may be used when contact and bending fatigue strengths generally achieved with carburizing and hardening are not required. Sometimes, the process is selected in place of more costly nitriding, which cannot economically produce deeper cases that may be required. Among the various induction-hardening methods, contour induction hardening is preferred when high root hardness and close control of case depth are needed. Induction hardening does, however, have some advantages over carburizing, such as less distortion, particularly in thin-rimmed internal gears.

It is a good process for low-cost, uniform quality, high-production gears where a sound development program can be economically justified before a gear is put into production. It is a risky process for job-shop work where fewer parts are made and cannot support any development program.

## Recent Advancements in Induction Hardening

To improve quality of induction hardening, a relatively new method has been developed based on dual-frequency heating as described subsequently.

### *Dual-Frequency Process*

The dual-frequency process uses two different frequencies for heating: high and low. At first, the gear is heated with a relatively low-frequency

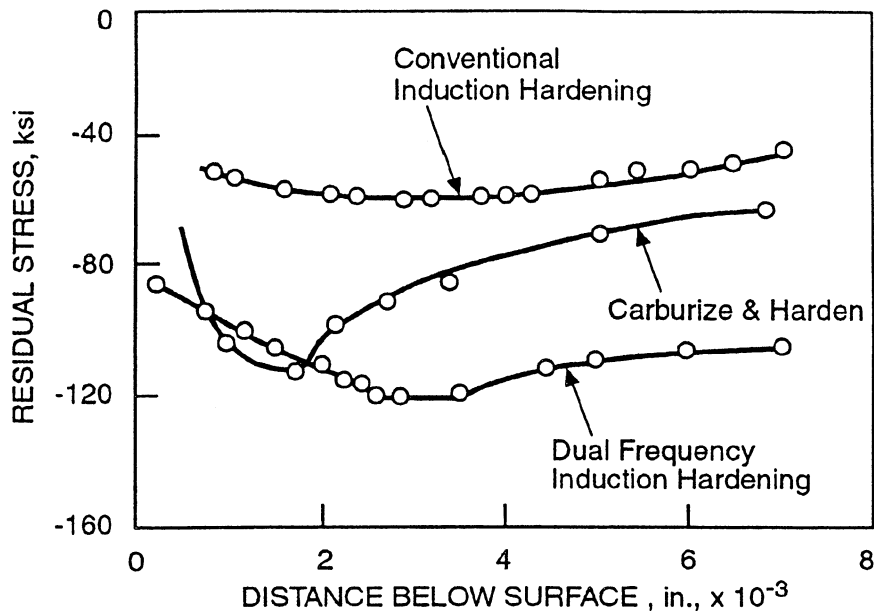
source (3–10 kHz), providing the energy required to preheat the mass of the gear teeth. This step is followed immediately by heating with a high-frequency source, which ranges from 100 to 270 kHz, depending on the diametral pitch of the gear. The high-frequency source rapidly heats the entire tooth surface to the hardening temperature. The gear then is quenched for the desired hardness.

The process is usually computer controlled. Because it is fast, surfaces remain clean and free from carbon depletion and scale, and the core material retains its original properties. The process puts only the necessary amount of heat into the part (much less than single-frequency induction); hence, case depth and gear quality level can be met precisely.

**Residual (compressive) stress levels** in a gear tooth induction hardened by the dual-frequency method are considerably higher than those in the single-frequency induction method. Figure 9.5 shows comparative stress levels between single-frequency induction, dual-frequency induction systems, and carburized and hardened gear tooth.

**Distortion.** Because the amount of heat applied by the dual-frequency process is considerably less than single frequency, heat treat distortion is significantly lower. In a test with gears (8 DP; 54 teeth; 29.21 mm, or 1.15 in., face width) made from AISI 5150, results showed distortion on any gear geometry dimension to be less than  $\pm 0.0102$  mm ( $\pm 0.0004$  in.).

**Materials.** A variety of materials can be used. Materials that have been successfully contour hardened by the dual-frequency method include AISI 1050, AISI 4140, AISI 4340, AISI 4150, and AISI 5150.



**Fig. 9.5** Residual compressive stress distribution—induction hardening and carburizing

**Applications.** Dual-frequency process is superior to regular induction hardening and is particularly useful for higher root hardness and close control of case depth.

### ***Flame Hardening***

Flame hardening is a process similar to induction hardening for heating the surface layers of steel above the transformation temperature by means of a high-temperature flame and then quenching. In this process, the gas flames impinge directly on the tooth surface to be hardened. The rate of heating is very rapid, although not as fast as with induction heating. Plain carbon steels usually are quenched by a water spray, whereas the rate of cooling of alloy steels may be varied from a rapid water quench to a slow air cool, depending on the composition of steel.

Any type of hardenable steel can be flame hardened. For best results, the carbon content should be at least 0.35%, the usual range being 0.40 to 0.50%.

Gases used for flame heating are acetylene and propane. Each of these gases is mixed with air in particular ratios and burnt under pressure to generate the flame that the burner directs onto the workpiece. Simple torch-type flame heads also are used to manually harden teeth. Since there is no automatic control of this process, high operator skill is required.

The general application of flame hardening is to the tooth flanks only, except when spin flame hardening is applied. The spin flame process is capable of hardening the whole tooth and also below the root. Certainly, this hardening increases distortion.

Gears are flame hardened only when they are of large size and the quality requirement is generally below AGMA class 7.

# CHAPTER 10

---

---

## Selection of Heat Treat Process for Optimum Gear Design

THE SUCCESSFUL DESIGN and manufacture of gears is influenced largely by design, material selection, and proper heat treatment. Close cooperation between the design engineer and the metallurgist is essential during the gear design process rather than after the gears are in production and rejections are occurring in heat treatment or failures in service. For years, material selection has been based on prior experience or some trial-and-error methods. A background of materials science is a valuable asset in the design and development of gears. This knowledge helps to eliminate guesswork from design.

The main objective of heat treating gears is to increase the life of the gears under service conditions. As discussed earlier, of the various heat treat processes, carburizing and hardening is used most often for optimum gear performance in power transmission service. Approximately 60% of gears in this type of service are carburized and hardened. Occasionally, other processes such as nitriding or induction hardening are selected because of specific customer requirement, distortion problems with carburizing, or size of gears.

The intent of this chapter is to make gear engineers aware of the comparative costs associated with the various heat treat processes for different gear materials. There are a number of items addressed in this chapter that need to be carefully evaluated before finalizing a design decision.

### Materials Selection

---

Materials selection is one of the most important items for consideration to control gear cost. In general, high-alloy steels cost more than low-alloy steels. Vacuum-melted steels cost more than air-melted ones. The cleaner



the material is (AMS 2300), the higher the cost will be. Sometimes, selection of high-cost materials (vacuum-melted, high-alloy clean steel) helps to achieve an optimum gear design. It is thus important to develop a table of standard materials on the basis of overall cost. Table 10.1 shows the suggested materials for each type of heat treat process based on the experience of the author and other gear engineers employed in industrial and aerospace industries.

The benefits of materials standardization are:

- Reduced material cost—volume buying
- Known machining characteristics—optimum selection of cutting tools
- Known heat treat cycle for required case and core properties
- Known heat treat problems—distortion, growth, and so on
- Dependable mechanical properties—large field data

**Materials Feature.** The cost of materials also varies whether the materials are available in a bar form or whether forging is required. The impact on cost is given in Table 10.2.

**Table 10.1 Suggested materials for different gear heat treat processes**

Process	Suggested materials
Through hardening	AISI 4140 (AMS 6382)(a) AISI 4340 (AMS 6414) HP 9-4-30 (AMS 6526) Maraging 300 (AMS 6514)
Nitriding: Low-case, high surface hardness 60 HRC and higher	Nitralloy 135M (AMS 6471)(a) Nitralloy N
Nitriding: Deep-case, surface hardness below 60 HRC	AISI 4140 (AMS 6382) AISI 4330M (AMS 6411) AISI 4340 (AMS 6414)(a)
Induction hardening	AISI 4140 (AMS 6382) AISI 4340 (AMS 6414)(a) AISI 5150
Carburizing and hardening	AISI 4320 (AMS 6299) AISI 4330M (AMS 6411) AISI 8620 (AMS 6276) AISI 9310 (AMS 6265)(a) HP 9-4-30 (AMS 6526) M50 Nil (AMS 6490) Pyrowear 53 (AMS 6308)

(a) Preferred selection

**Table 10.2 Cost of material**

Material feature	Cost factor
Bar(a)	1.0
Forging	2.5

(a) Indicates preferred selection

## Gear Design Feature

Sometimes, multiple gears of different geometry and number of teeth are integral on the same shaft. Because case depth requirements may be different for different sized teeth, it creates some difficulty during heat treatment. To satisfy case depth on different sized teeth, heat treat cycle time may have to be adjusted, affecting the cost (Table 10.3).

**Case Depth Tolerance.** As with any other manufacturing process, the wider the tolerance on dimension is, the lower the cost will be. In heat treatment, the cost factors for nitriding and carburizing are found to be as shown in Table 10.4.

**Surface Coverage for Carburizing or Nitriding.** Partial coverage costs more, as indicated in Table 10.5.

**Finishing Cost of Gear.** The higher the quality is, the higher the cost of the gear will be (Table 10.6).

**Table 10.3 Cost of design feature**

Case	Cost factor
Single case depth(a)	1.0
Multiple case depths (integral design of gears with different pitch)	2.5

(a) Indicates preferred selection

**Table 10.4 Cost of case depth tolerance**

Tolerance, mm (in.)	Cost factor	
	Nitride	Carburize
$\pm 0.05$ ( $\pm 0.002$ )	1.4	2.0
$\pm 0.10$ ( $\pm 0.004$ )	1.0	1.2
$\pm 0.13$ ( $\pm 0.005$ )(a)	0.8	1.0

(a) Indicates preferred selection

**Table 10.5 Cost of gear surface coverage**

Coverage	Cost factor
All over(a)	1.0
Partial	3.5

(a) Indicates preferred selection

**Table 10.6 Gear finishing cost**

AGMA class	Cost factor (based on finish grinding)
8 and 9	1.0
10 and 11(a)	1.2
12 and 13(b)	1.5
14	2.0
15 and higher	Unknown

(a) Preferred up to surface speed of 25.4 m/s (5000 ft/min). (b) Preferred above 25.4 m/s (5000 ft/min)

## General Conclusions

---

Considering the benefits and limitations of various heat treat methods, case hardening certainly offers a number of advantages over the through-hardening processes. Case-hardened gears have high fatigue life. Gearboxes designed with such gears are about 15 to 20% smaller in size (volume) than those with through-hardened gears. Again, of the various case-hardening processes, carburizing and hardening is the most preferred method for optimum design of gears within the capacity of carburizing equipment. Currently, over 60% of industrial and aerospace gears are made by this process. With further development of alloy steels and carburizing technology to control distortion, usage of carburized-and-hardened gears will continue to increase.

# Index

## A

- Acid pickling**, to remove white layer ..... 138
- $A_{c1}$  temperature** ..... 10
- $A_{c3}$  temperature** ..... 10
- and carbon solubility ..... 34
- Aerospace applications** ..... 2–3, 18
- carbonitrided steels ..... 173
- effective case depth for high-alloy steel
- gears ..... 53–54
- end-quench hardenability curves of
- gear steels ..... 50, 51(F)
- for nitriding ..... 133
- materials selection
- recommendations ..... 186(T)
- tempering after carburizing and
- hardening of gears ..... 42
- through-hardened gear rack ..... 26–32(F,T)
- total case depth estimation ..... 59(F)
- vacuum-melted steels ..... 83
- Aerospace Material Specifications (AMS)**
- controlling degree of material
- cleanliness ..... 78–81(T)
- 2300 ..... 78, 79, 86
- 2300, for nitrided gears ..... 158
- 2300, induction hardening ..... 182(T)
- ion plasma nitriding ..... 163(T)
- 2301 ..... 78, 79
- 2304 ..... 78, 79, 86
- 2304, for nitrided gears ..... 158
- 2304, induction hardening ..... 182(T)
- 2304, ion plasma nitriding ..... 163(T)
- $A_{e1}$  temperature** ..... 10, 11(F), 12(F)
- Age-hardening steels** ..... 29
- composition ..... 28(T)
- Air-melted steels**
- costs ..... 83–85(F)
- distortion derating factors ..... 107(T)
- Air melting**
- Aerospace Material Specification 2301,
- quality steel production ..... 78
- Aerospace Material Specification 2304,
- quality steel, nonmetallic inclusions
- under strict control ..... 78
- $A_{cm}$  line** ..... 9
- Allowable contact stress** ..... 105–106(F)
- Alloying elements**
- effect on hardenability of steels ..... 45
- effect on heat treat distortion ..... 81
- Alloying segregation** ..... 77, 84
- Alloy steels**
- desired microstructures and properties ..... 1
- proportionality factor for gas
- carburizing ..... 35
- Almen method**, for measuring and
- duplicating shot-peening
- intensity ..... 116–117, 118
- Alpha ferrite** ..... 8
- Alpha iron** ..... 5, 6(F), 8
- Alumina-type inclusions** ..... 84(F)
- Aluminum**, alloying element effect in
- nitriding steels ..... 140
- Aluminum nitrides** ..... 133
- Aluminum oxide**, vitrified, grinding
- wheel ..... 109
- Ambient temperature** ..... 36
- American Gear Manufacturers Association (AGMA)** ..... 3
- cleanliness standards for different
- grades of materials ..... 78–79
- Ammonia**, in nitriding atmosphere ..... 133
- Ammonia dissociation rate** ..... 138
- Anisotropy**, definition ..... 77
- Annealing** ..... 21–22, 23(T)
- after normalizing to obtain proper
- hardness for machinability ..... 87(F)
- before induction hardening ..... 176
- full ..... 21–22
- full-length racks ..... 31
- process ..... 21, 22
- subcritical, prior to nitriding ..... 134
- Applications** ..... 26–32(F,T)
- $A_{r1}$  temperature** ..... 10
- $A_{r3}$  temperature** ..... 10
- $A_r$  transformation** ..... 10
- $A_r'$  transformation** ..... 10–11(F), 13
- $A_r''$  transformation** ..... 10–11(F), 13
- $A_{r1}$  transformation** ..... 10
- $A_{cm}$  temperature**, carburizing above ..... 38
- $A_1$  temperature** ..... 8–9
- $A_3$  temperature** ..... 8–9
- Austenite** ..... 8, 9, 11(F)
- composition effect on hardenability ..... 47
- decomposition to bainite ..... 12–13(F)
- decomposition to pearlite ..... 11–12(F)

<b>Austenite (continued)</b>	
and heat treat distortion .....	77
single-phase .....	8
transformation (decomposition) ....	10–16(F)
transformation to martensite .....	13
<b>Austenitic transformation</b> .....	77
<b>Austenitization</b> .....	77
<b>Austenitizing</b> , to eliminate banding .....	84
<b>Austenitizing temperature</b> , and microstructure of carburized cases .....	68
<b>Automotive applications</b> .....	2, 18
for nitriding .....	133
quenching conditions .....	37
total case depth estimation .....	59(F)
<b>B</b>	
<b>Bainite</b> .....	12–13
heat treating to reduce degree of distortion .....	90
in carburized cases .....	68
<b>Banding</b> .....	84, 85(F), 126(F)
absent in gear failure analysis .....	156
<b>Base helix angle</b> .....	60
<b>Beach marks</b> .....	154(F)
<b>Bending fatigue</b> .....	1
<b>Bending fatigue failure</b> .....	58
<b>Bending fatigue life</b> of carburized and hardened gears .....	18, 53, 58, 59, 62
and grind burn .....	109
of nitrided gears .....	142, 143–144, 144(F)
reduced by low core hardness .....	44
and shot peening .....	113, 114
<b>Bending fatigue strength</b> of carburized and hardened gears .....	58
and core hardness of tooth, carburized and hardened .....	62–64(F)
of failed nitrided gear .....	154, 157, 158
retained austenite effect .....	72, 75(F)
vs. grain size .....	65(F)
<b>Bending fatigue stress</b> , of carburized and hardened gears .....	78
<b>Bending strength</b> , of induction-hardened materials .....	179
<b>Bending stress</b> , of carburized and hardened gears .....	54
<b>Blank design</b> .....	91–100(F)
dumb-bell shape pinion .....	93–94(F)
heat treat cracks at tooth edges .....	98–100(F)
long slender pinions .....	91–92, 94(F)
pinion shaft with threads .....	97–98(F)
wide face width gears, for uniform hardness .....	94–97(F)
<b>Body distortion</b> .....	76
<b>Boost-diffuse cycle</b> .....	105
<b>Brinell hardness at core</b> , nitriding steels .....	137(T)
<b>Brinell hardness number</b> , of tooth surface .....	106(F)
<b>Brinell hardness scale</b> .....	21, 22(T), 23(T), 106(F), 137(T)
<b>C</b>	
<b>Carbide precipitation</b> , and hardening .....	39
<b>Carbides</b> metallographic standard for carburized, hardened, and tempered cases ....	70(F)
undissolved, effect on hardenability ..	47, 48
<b>Carbon</b> content effect on case property ..	50–61(F,T)
content effect on hardenability .....	46
content effect on induction hardening ...	176
content effect on maximum attainable hardness of quenched steels ..	17, 18(F)
content effect on surface hardness of induction-hardened materials .....	178
content in carburized cases .....	68
dissolved, and austenite volume .....	77
effect on critical points of iron .....	7–8(F)
effect on start of martensite transformation of high-purity iron-carbon alloys .....	16(F)
solubility and $A_{c3}$ temperature .....	34
surface, and grind burn .....	108
surface, carburizing processes effect .....	66–67(F)
<b>Carbonaceous gases</b> , for gas carburizing .....	34
<b>Carbon and alloy steels</b> , induction hardening .....	176
<b>Carbon gradient</b> .....	66–67(F)
in carburized cases .....	68
<b>Carbonitrided steel</b> . <i>See also</i> Carbonitriding. composition .....	172
<b>Carbonitriding</b> <i>See also</i> Carbonitrided steels. ....	2, 3, 19, 171–173.
advantages .....	172, 173
applications .....	173
case depth .....	172, 173
case imparted .....	171
core hardness .....	173
definition .....	171
furnace atmosphere .....	171
heat treat distortion .....	172
materials .....	172
as modified gas carburizing process .....	171

- nitrogen addition effects ..... 171
- temperature range ..... 171
- vs. gas carburizing ..... 172, 173
- Carbon potential** ..... 34, 36, 66
  - effect on carbon profiles ..... 67(F)
  - effect on retained austenite ..... 73
- Carbon profiles** ..... 67(F)
- Carbon steels**
  - phase diagram ..... 9(F)
  - plain, austenite transformation ..... 13
  - plain, flame hardening ..... 184
- Carburizing.** *See also* Carburizing and hardening; Carburizing grade gear steels.
  - agents ..... 33
  - case depth tolerance, costs incurred in design ..... 187(T)
  - definition ..... 33
  - distortion of gears ..... 27
  - effect on microstructure ..... 68
  - effect on quality of gear geometry ..... 1
  - effect on surface carbon ..... 66–67(F)
  - methods ..... 33
  - problem encountered ..... 68–76(F,T)
  - vs. carbonitriding ..... 172, 173
- Carburizing and hardening** *See also* Carburizing; Carburizing grade gear steels. .... 2, 3, 18, 19, 33–132(F,T).
  - actual stock removal and tooth surface hardness ..... 103–105(F)
  - advantages ..... 3
  - applications ..... 123, 188
  - boost-diffuse cycle ..... 105
  - carbon content and case property ..... 50–61(F,T)
  - carburizing atmosphere uniformity ... 88, 90
  - cold treatment ..... 43–44
  - cost of carburizing ..... 122–123(T)
  - cycle time of carburizing grade gear steels ..... 122, 127
  - disadvantages ..... 123
  - distortion control case history ..... 123–132(F,T)
  - distortions held to one AGMA class
    - below pre-heat-treat quality ..... 101
  - dumb-bell shape pinion ..... 93–94(F)
  - effect on carbon content of gear teeth .... 33
  - eutectoid point ..... 18
  - gas carburizing ..... 33–37(F)
  - grind burn causes ..... 108–110(F)
  - grinding stock allowance on tooth flanks to compensate for distortion ..... 100–111(F,T)
  - hardness requirements in case and core for different classes of gears ..... 68, 69(T)
- heat treat distortion ..... 76–100(F,T)
- long slender pinions ..... 91–92, 94(F)
- material selection for carburized gears ..... 44–45(T)
- materials recommended ..... 186(T)
- metallographic standard ..... 70(F)
- metallographic standard for case carbides ..... 71(F)
- metallographic standards for core structure ..... 72(F)
- microstructure requirements in case and core for different classes of gears ..... 68, 69(T)
- objective ..... 33
- power transmission service industry applications ..... 185
- producing highest torque-carrying capacity of gears ..... 2
- recarburizing ..... 42–43
- retained austenite effect on gear performance ..... 70–76(F)
- surface oxidation effect ..... 64
- temperature for carburizing ..... 35–36
- vs. induction hardening ..... 181(F), 182, 183(F)
- Carburizing grade gear steels** *See also* Carburizing; Carburizing and hardening. .... 2
  - annealing temperature ..... 45(T)
  - banding ..... 84, 85(F)
  - carbon profiles ..... 67(F)
  - carburizing cycle time ..... 122
  - carburizing temperature ..... 45(T)
  - case hardness ..... 122
  - case history of heat treat distortion control ..... 123–132(F,T)
  - chemical analysis ..... 79
  - composition ..... 44(T), 121
  - core hardness range vs. diametral pitch of tooth ..... 64, 65(T)
  - distortion ..... 122
  - distortion characteristics ..... 90–91(T)
  - distortion derating factors ..... 107(T)
  - effective grind stock selection ..... 102
  - gas contents before and after consumable electrode vacuum melting ..... 82(T)
  - grind burn ..... 110(F)
  - hardenability ..... 121
  - hardening temperature ..... 45(T)
  - hardness and microstructure requirements in case and core by class ..... 68, 69(T)
  - hardness gradients ..... 103–105(F)

<b>Carburizing grade gear steels (continued)</b>	
hardness vs. case depth of gears .....	55(F)
heat treating data .....	45(T)
inspection format .....	126, 127(F)
Jominy test results .....	79–80
martensite start temperature .....	45(T)
mechanical properties .....	52(T)
mechanical properties of air-melted vs. consumable-electrode, vacuum-melted steels .....	85(T)
microcleanliness rating (ASTM A 534) .....	80
normalizing temperature .....	45(T)
quenching .....	52(T)
reheat temperature .....	45(T)
shot peening parameters .....	119–120
slope of hardness vs. case depth gradient unique .....	101
tempering .....	52(T)
<b>Case carbides, metallographic standard</b> in carburized, hardened and tempered cases .....	71(F)
<b>Case carburizing and hardening. <i>See</i></b> Carburizing and hardening.	
<b>Case crushing</b> .....	59, 140
stress location on gear tooth .....	62–63
<b>Case depth</b> .....	2, 35, 36
after nitriding .....	2
at tooth tips, recommended values .....	61(T)
better control with vacuum carburizing .....	37
carbonitrided steels .....	172, 173
copper plating for control at tooth tip .....	69–70, 75(T)
cost factors for nitriding steels .....	145, 145(T)
and costs in design .....	187(T)
difference in thickness as problem .....	68–69, 73(F), 74(F)
and distortion in nitriding .....	146
of failed nitrided gear .....	156
for nitriding .....	135(T)
for various times and temperatures, gas carburizing of gear steel .....	35(F)
of gear tooth .....	51–52
grain size effect .....	61(T)
in carburized cases .....	68
induction hardened materials .....	178–180(F,T)
induction hardening problems with uniformity .....	180–181(F)
in nitriding .....	134–135
ion plasma nitriding .....	161
measurement .....	52–53
nitriding cycle time .....	135–136(F)
nitriding steels (ion nitriding) .....	161(T)
optimum for each tooth size .....	59–60(T)
recommended at pitch line .....	60(T)
ring gear in ion nitriding case study .....	165, 167(F)
tempering temperature effect .....	41
vs. carburizing cost .....	122(T)
vs. surface hardness .....	95, 96(F)
<b>Case depth-shear stress theory</b> .....	54–58(F)
<b>Case depth tolerance</b> cost factors for nitriding steels .....	145, 145(T)
and costs in design .....	187(T)
vs. carburizing cost .....	122(T)
<b>Case hardening, vs. through hardening</b> ...	188
<b>Case hardness</b> carbonitrided steels .....	171
of carburizing grade gear steels .....	122
failed nitrided gear case study ..	155, 157(F)
induction-hardened materials .....	182(T)
measurement location .....	62(F)
nitriding steels (ion nitriding) .....	163(T)
ring gear in ion nitriding case study .....	165, 167(F)
tempering temperature effect .....	41
<b>Case history, carburized and hardened</b> gears, distortion control .....	123–132(F,T)
<b>Cast irons, induction hardening</b> .....	176
<b>Cementite</b> .....	7(F)
in carburized cases .....	68
<b>Cementite precipitation</b> .....	9
<b>Chamfering</b> .....	98–100(F)
<b>Chemical analysis</b> of carburizing grade gear steels .....	79
for heat verification .....	86
<b>Chromium</b> content effect in nitriding steels ....	140, 147
content effect on gear hardness and hardenability .....	49
<b>Chromium-molybdenum steels</b> air-melted, nitrided gears with negligible distortion .....	147
case history .....	148–152(F)
nitrided .....	147
<b>Chromium-molybdenum-vanadium</b> steels, nitriding .....	147, 152
<b>Chromium nitrides</b> .....	133
<b>Cleanliness</b> .....	78–81(T)
as major factor in cost of gears .....	185–186
<b>Cobalt, content effect on gear hardness</b> and hardenability .....	50
<b>Coefficient of friction</b> .....	56, 57(F)
<b>Coefficient of nitridability</b> .....	165

- Cold treatment**
    - effect on retained austenite ..... 73–76
    - equipment for ..... 44
    - temperature range used ..... 44, 76
  - Cold working**, effect on cold treatment
    - transformation result ..... 76
  - Compound nitride zone** ..... 137
  - Compressive hoop stress** ..... 56
  - Compressive stress**, of nitrided gears ..... 144
  - Consumable electrode vacuum melting** ..... 82(T)
  - Contact fatigue** ..... 1
    - carbon content effect in carburized gears ..... 50
  - Contact fatigue life** ..... 109
    - of nitrided gears ..... 134
    - and retained austenite content ..... 73
  - Contact fatigue stress**, specifications by AGMA for three different grades of materials ..... 78, 79
  - Contact stress** ..... 54–55
  - Continuous cooling curves** ..... 13, 14(F)
  - Controlled nitride process** ..... 165–167
  - Cooling media** ..... 38
  - Cooling rate**
    - effect on retained austenite ..... 73
    - effect on transformation temperatures and decomposition products of austenite, eutectoid carbon steel ..... 10, 11(F)
    - and section thickness ..... 17
  - Copper plating** ..... 33
    - before carburizing, to control case depth ..... 69–70, 75(T)
    - not advisable for selective ion nitriding ..... 160–161
    - to mask gears for gas nitriding ..... 134
  - Core hardening**, prior to nitriding ..... 134
  - Core hardness**
    - and bending fatigue strength ..... 58, 62–64(F)
    - carbonitrided steels ..... 173
    - of failed nitrided gear ..... 155, 156
    - fillet radius and holes in tooth spaces ..... 97(F)
    - of gear teeth ..... 59, 62–67(F,T)
    - and grain size ..... 64–66(F)
    - induction-hardened
      - materials ..... 178, 179, 182(T)
    - and maximum bending fatigue strength ..... 64(F)
    - measurement location ..... 62(F), 63(F)
    - nitriding steels
      - (ion nitriding) ..... 161(T), 163(T)
    - range, vs. diametral pitch ..... 64, 65(T)
    - related to hardenability and alloying elements ..... 44–45
    - ring gear in ion nitriding case study ..... 165, 167(F)
  - Core structure**, metallographic standards for carburizing, hardening, and tempering ..... 72(F)
  - Core treatment** ..... 1
  - Corrosion resistance**, increased with cobalt additions ..... 50
  - Cost**
    - of carburizing, vs. carburizing features ..... 123(T)
    - of carburizing, vs. case depth ..... 122(T)
    - of carburizing, vs. case depth tolerance ..... 122(T)
    - of carburizing, vs. surface coverage ..... 123(T)
    - manufacturing ..... 1
    - manufacturing, of carburizing and grinding ..... 2
    - manufacturing, of finishing of gears ..... 3
    - manufacturing, of rack ..... 27
    - of nitriding ..... 2, 145, 146(T)
    - and selection of heat treat process for optimum gear design ..... 185–188(T)
  - Cracking** *See also* Microcracking. .... 134
    - from induction hardening ..... 181
  - Crack-initiated pit formation** ..... 55
  - Critical applications**
    - AGMA cleanliness standards for material grade ..... 78
    - carburizing grade gear steels, heat treat characteristics ..... 121–122
    - carburizing grade gear steels, preference ..... 122
    - hardness and case thickness variations ..... 96
  - Critical cooling rate** ..... 14–15
  - Critical points** ..... 10
  - Critical transformation range** ..... 9(F), 10
  - Cubic boron nitride (CBN) grinding wheels** ..... 109
  - Cyclic bending stress** ..... 58
- ## D
- Decarburization** ..... 66
    - gears free from, for nitriding ..... 134
    - prevention of ..... 38
  - Decomposition**, of austenite ..... 10–16(F)
  - Deep-hardening steels** ..... 46
  - Delta ferrite** ..... 8
  - Delta iron** ..... 5, 6(F), 8
  - Design of gears**
    - case depth requirements, effect on cost ..... 187(T)



## Design of gears (continued)

- case depth tolerance requirements,
  - effect on costs ..... 187(T)
- costs of design features ..... 187(T)
- finishing requirements, effect on
  - costs ..... 187(T)
- selection of heat treat
  - process ..... 185–188(T)
- surface coverage requirements, effect
  - on costs ..... 187(T)
- Dew point**, control, in carburizing ..... 90
- Diametral pitch** ..... 51, 59
  - compared to hardness vs. case depth
    - gradients ..... 139
  - vs. core hardness range ..... 64, 65(T)
  - vs. core hardness range
    - of tooth ..... 64, 65(T)
- Differential skin etch reflection** ..... 110
- Diffusion cycle (two-stage process)**,
  - nitriding ..... 140
- Diffusion process** ..... 137
- Diffusion zone** ..... 137
  - in controlled nitride process ..... 166
- Distortion**. *See* Heat treat distortion.
- Distortion derating factor (DDF)** ..... 107–108(F)
- Drilling**, full-length racks ..... 31
- Dual case**, vs. carburizing cost ..... 123(T)
- Dual frequency process, induction hardening** ..... 3, 182–184(F)
  - applications ..... 184
  - heat treat distortion ..... 183
  - materials ..... 183
- Ductility**
  - improved by tempering ..... 23
  - nitriding steels (ion nitriding) ..... 163
  - transverse, after vacuum melting ..... 83
- Dye penetrant inspection**, to check for cracks ..... 92

## E

- Effective case depth** ..... 52, 53, 60
  - after grinding ..... 101
  - of carburized and hardened gear in
    - case study ..... 127
  - failed nitrided gear case study .. 155, 157(F)
  - of high-alloy steel gears ..... 53–54(F)
  - induction-hardened materials .... 179, 180(F)
  - of nitrided gear teeeth ..... 136
- Electrical conductivity** ..... 5
- Elongation**
  - carburizing grade gear steels ... 52(T), 85(T)
  - improved after vacuum melting ... 83, 85(T)
  - nitriding steels ..... 137(T)

## Embrittlement, molybdenum content

- effect in nitriding steels ..... 147
- Endo gas**. *See* Endothermic gas.
- Endothermic gas** ..... 34
- End-quench hardenability**
  - curves ..... 50, 51(F)
- End-quench test** ..... 45–46(F), 47(F), 48(F), 49(F)
- Endurance (S-N curve)**, for nitrided gears ..... 142, 144(F)
- Energy-dispersive x-ray spectroscopy (EDS)**, of nitrided gear tooth
  - failure ..... 154
- Epicyclic gearbox, internal ring gear**, case history of ion plasma nitriding ..... 163–169(F)
- Epsilon iron nitrides** ..... 137
- Equilibrium** ..... 10
- European nitriding steels** ..... 146–147
  - composition ..... 154–155
  - gear failure case history ..... 154, 156(F)
- Eutectic alloy of iron and cementite** ..... 7–8
- Eutectoid carbon content** ..... 10, 12(F), 13
- Eutectoid carbon steel** ..... 11(F)
- Eutectoid point** ..... 18
- Eutectoid steel** ..... 8–9
- Expansivity** ..... 5

## F

- Failure analysis**, gearbox
  - example ..... 155–158(F)
- Failure modes** ..... 1
- Fatigue life**
  - nitrided gears ..... 142–144(F), 145(F)
  - shot peening effect ..... 112–113
  - of vacuum-melted steels ..... 83
  - white layer of nitrided gears ..... 138
- Fatigue resistance**, related to cleanliness
  - of steel ..... 83
- Fatigue strength**
  - induction-hardened materials ..... 179
  - nitriding steels (ion nitriding) ..... 163
  - shot peening effect on carburized gears ..... 112–113, 115, 119(F)
- Ferrite** ..... 8
  - and heat treat distortion ..... 77
  - in carburized and hardened gear
    - microstructure ..... 126(F)
  - in carburized cases ..... 68
  - in core structure, metallographic standards ..... 72(F)
- Ferrite precipitation** ..... 8–9
- Ferromagnetism** ..... 5
- Finishing**, and costs in design ..... 187(T)
- Finish-machining**, to reduce white-layer thickness ..... 138–139
- Flaking** ..... 82–83

- Flame hardening (induction hardening process)**
  - applications ..... 184
  - gases used for heating ..... 184
  - heat treat distortion ..... 184
  - limitations ..... 184
  - materials ..... 184
  - procedure ..... 184
  - spin flame hardening ..... 184
- Floer process** ..... 137
- Forgings**
  - effect on costs of gear production ..... 83
  - grain flow patterns ..... 86, 87(F)
- Free cementite** ..... 15
- Free ferrite** ..... 15
- Freezing point** ..... 7, 8
- Friction, coefficient of**
  - and nitriding ..... 152
- Full annealing.** *See* Annealing, full.
- Furnaces**
  - atmospheres, nitrogen-based . 125, 127, 132
  - atmospheric ..... 36–37, 59
  - batch ..... 36–37
  - continuous ..... 36–37, 39
  - endothermic ..... 66(F)
  - fluidized-bed ..... 36, 37, 66(F)
  - fluidized-bed, for carburizing ..... 123
  - for gas carburizing ..... 36–37
  - for heat treating racks ..... 29
  - horizontal-batch continuous ..... 39
  - in-out (batch)-type, for carburizing ..... 124, 131
  - load arrangement as distortion factor ..... 88–89(F)
  - microprocessor control system ..... 125
  - pusher-type continuous ..... 39
  - vacuum ..... 36, 37, 59, 66(F)
  - vacuum, for carburizing ..... 123
  - vacuum pulsation ..... 66(F)
- G**
- Gamma iron** ..... 5, 6(F)
- Gamma prime iron nitrides** ..... 137
- Gas carburizing** ..... 33–37(F), 39
  - equipment ..... 36–37
  - furnaces ..... 36–37
  - proportionality factor of material ..... 35
  - quenching medium ..... 35
  - temperature for ..... 34–36(F)
  - time duration ..... 34–35(F)
- Gas nitriding** ..... 3
- Gas turbogenerator applications** ..... 152
- Gear blank design, effect on heat treat distortion** ..... 81, 82(F)
- Gearboxes**
  - epicyclic ..... 26, 39
  - failure, case history ..... 152–158(F)
  - internal ring gear of, case history of ion plasma nitriding ..... 163–169(F)
  - through hardening effect ..... 26
- Gear grind burns** ..... 73, 108–110(F)
- Gear pitch diameter distortion** ..... 128
- Gears**
  - distortion from heat treating with through hardening ..... 25
  - heat treating overview ..... 17–19(F)
  - internal ring ..... 26
- Gear tooth**
  - core hardness ..... 62–67(F,T)
  - geometry, distortion in ..... 76
  - nomenclature ..... 111, 112(F)
  - overtempering ..... 111, 113(F), 114(F), 115(F)
  - root hardness ..... 25
  - tip and edge radii, recommendations for carburizing ..... 70, 75(T)
- Globular-type inclusions** ..... 84(F)
- Grain boundary nitrides, in nitrided gears** ..... 143(F)
- Grain flow**
  - absent in gear failure analysis ..... 156
  - patterns in gear forgings ..... 86, 87(F)
- Grain refinement, reheating of gears for ...** 40
- Grain size**
  - ASTM grain size numbers and grains per square inch ..... 61(T)
  - of austenite, and hardenability ..... 47
  - case depth related to ..... 61(T)
  - and core hardness ..... 64–66(F)
  - nitriding steels (ion nitriding) ..... 161(T)
  - standards (ASTM) of steel ..... 87(F)
  - vs. bending fatigue strength ..... 65(F)
  - vs. pitting fatigue strength ..... 65–66
  - vs. temperature, carburized steels ..... 66
- Grain structure**
  - and heat treat distortion ..... 78
  - normalizing for refinement ..... 88
- Grind burns** ..... 108–110(F)
  - inspection and limited acceptance criteria ..... 110–111
  - and retained austenite % content ..... 73
- Grinding** ..... 1–2, 21, 53
  - actual stock removal and tooth surface hardness ..... 103–105(F)
  - alternative to masking for selective ion nitriding ..... 161
  - before nitriding ..... 149
  - distorted gears ..... 101–102(F)
  - dry, and grind burn ..... 109

## Grinding (continued)

- during manufacturing of full-length racks ..... 31, 32(T)
- effect on case and surface hardness of teeth ..... 2
- equipment ..... 109, 110
- finish, after nitriding ..... 150–152
- of long slender pinions ..... 91–92, 94(F)
- machine setup ..... 101–102(F)
- nitrided gears ..... 141
- not recommended for nitrided gears .... 148
- parameters contributing to grind burn ... 109
- retained austenite content effect ..... 73
- side effects on carburized and hardened gears ..... 108–111(F), 112(F), 113(F), 114(F), 115(F)
- of stock allowance on tooth flanks to compensate for distortion ..... 100–111(F,T)
- wet, and grind burn ..... 109

## H

### Hardenability

- alloying elements effect ..... 47–50
- carbonitrided steels ..... 171
- carburizing and hardening ..... 45–50(F)
- of carburizing grade gear steels ..... 121
- definition ..... 45
- factors influencing ..... 47
- factors that increase ..... 47–48
- factors that reduce ..... 47–48
- gear steel selection by ..... 50
- of steel, effect on heat treat distortion ... 81
- test methods ..... 45–46(F), 47(F), 48(F), 49(F)

### Hardenability check, for heat

- verification ..... 86

### Hardenability curves ..... 47(F), 48(F), 49(F)

### Hardening ..... 37–40

### Hardness

- affected by carbon content in quenched steels ..... 17, 18(F)
- alloying elements effect ..... 47–50
- carburizing and hardening ..... 45–50(F)
- definition ..... 45
- of failed nitrided gear ..... 156
- for nitrided gears ..... 141(T)
- as function of increased carbon content ..... 13
- requirements for different classes of carburized and hardened gears ..... 68, 69(T)

### Hardness callout ..... 25

### Hardness gradient

- of carburized and hardened gear in case study ..... 127, 128(F)
- of carburized and hardened gear teeth ..... 103–105(F)
- nitrided tooth vs. carburized tooth .... 139(F)

### Hardness profiles, at different locations

- of gear tooth ..... 74(F)

### Hardness-test scales, relation between

- various scales ..... 21, 22(T)

### Hardness vs. case depth gradient, slope

- unique to each carburizing grade steel ..... 101

### H-band steels ..... 46

### Heat treat distortion

- after carbonitriding ..... 172
- after carburizing and hardening ..... 76–100(F,T)
- after carburizing and hardening, types .... 76
- after ion plasma nitriding ..... 163(T)
- alloy elements effect ..... 81
- of carburizing grade gear steels ..... 122
- case history of carburized and hardened gears ..... 123–132(F,T)
- characteristics of some gear materials ..... 90–91(T)
- design improvements for control of ..... 91–100(F)
- dual-frequency process, induction hardening ..... 183
- flatness of rims in carburized and hardened gears in case study ..... 127, 128(F), 131
- gear blank design effect ..... 81, 82(F)
- grinding stock allowance on tooth flanks for compensation . 100–111(F,T)
- growth over pins of carburized and hardened gears in case study ..... 127–128, 129(F)
- hardenability effect ..... 81
- hub popping of carburized and hardened gears ..... 127, 129(F), 131
- in controlled nitride process ..... 167
- induction-hardened materials .... 181–182(T)
- in Grade 1 (AGMA) materials for industrial applications ..... 79
- in nitrided gears ..... 145–147(T)
- in nitrided gears, material selection factor ..... 146
- load arrangement ..... 88–89(F)
- material factors ..... 77–81(T)
- measurement of gear distortions ..... 85–86
- mechanics of ..... 77
- process factors ..... 77–81(T)
- quenchant flow effect ..... 81

- quenchant speed effect ..... 81
- quenchant temperature effect ..... 81
- quenching method effect ..... 81
- recommendations to minimize distortion ..... 86–90(F)
- of ring gear in ion nitriding
  - study ..... 165, 169(F)
- through-hardened gears, rating of ..... 26(T)
- vacuum-melted vs. air-melted alloy steels ..... 81–85(F,T)
- Heat-treat facilities**, to minimize carburizing heat treat distortion ..... 124–125, 131
- Heat treating**
  - carburized and hardened gear in case study ..... 127
  - carburizing grade gear steels, characteristics ..... 121–122
  - overview of processes, for gears ..... 17–19(F)
  - of racks ..... 30–32(T)
  - uniform response by processing gears together ..... 78
- Heat verification** ..... 86
- Helix deviations** ..... 101, 102
- Hertzian contact band** ..... 58(F)
- Hertzian contact pressure** ..... 58(F)
- Hertzian contact stress** ..... 54
- High-alloy steels** ..... 2–3, 39
  - aerospace applications ..... 2–3
  - effective case depth of gears ..... 53–54(F)
  - maximum bending fatigue strength ..... 64
  - tempering temperature effect on core hardness ..... 42(F)
  - through hardening effect on Brinell hardness range ..... 23(T)
- Highest point of single-tooth contact (HPSTC)** ..... 55, 56(F)
- High-speed applications**, AGMA cleanliness standards for material grade ..... 79
- Hobs** ..... 2
- Honing** ..... 1
  - after heat treatment ..... 129, 131
  - of carburized and hardened gears ..... 111–112
  - full-length racks ..... 32
  - nitrided gears ..... 141
  - to remove white layer ..... 138
  - to remove white layer off ion plasma nitrided gears ..... 160
- Hub popping** ..... 127, 129(F), 131
- Hydrocarbon gases**, for gas carburizing .... 33
- Hypereutectoid steels** ..... 8–9
  - decomposition to free cementite plus pearlite ..... 15
- Hypoeutectoid steels** ..... 8
  - decomposition to free ferrite and pearlite ..... 15
  - normalizing and annealing ..... 23
- I**
- Impact resistance**, improved by tempering ..... 23
- Inclusions**, determination of ..... 83, 84(F), 85
- Induction-hardened materials** *See also* Induction hardening. .... 176
  - AMS quality ..... 182(T)
  - case hardness ..... 182(T)
  - core hardness ..... 182(T)
  - heat treat distortion ratings ..... 181–182(T)
- Induction hardening** *See also* Induction-hardened materials. .... 2, 3, 19, 175–184(F,T)
  - applications ..... 182
  - carburized and hardened gears below 1 diametral pitch (DP) ..... 60
  - case depth ..... 178–180(F,T)
  - composition of materials ..... 176
  - contour induction hardening ..... 182
  - current frequencies for heating ..... 178(T), 179(T)
  - current frequency vs. case depth ..... 179(T)
  - definition ..... 175
  - dual-frequency process ..... 182–184(F)
  - durability limitations ..... 180–181
  - equipment ..... 175–176, 177
  - flame hardening process ..... 184
  - for large-sized gears ..... 3
  - heating ..... 177–178(T)
  - heat source ..... 175, 178–179
  - hot rolled vs. cold rolled materials ..... 176
  - materials ..... 176
  - materials recommended ..... 186(T)
  - methods (patterns) ..... 176–177(F)
  - problems in attaining uniform case depth ..... 180–181(F)
  - procedure ..... 175
  - quenching ..... 175, 176, 178
  - spin hardening ..... 176–177(F)
  - surface hardness ..... 178–180(F,T)
  - tempering after quenching ..... 178
  - time duration of treatment ..... 175, 178
  - tooth-to-tooth (or contour) hardening ..... 176–177(F)
  - vs. carburizing and hardening ..... 181(F), 182, 183(F)
  - vs. quench and temper process ..... 24
- Industrial applications** ..... 2, 18

<b>Industrial applications (continued)</b>	
AGMA cleanliness standards for	
material grade .....	79
carburized and hardened gears .....	123
cost as factor .....	90
diametral pitch .....	60
end-quench hardenability curves of	
gear steels .....	50, 51(F)
for nitriding .....	133
hardness and case thickness	
variations .....	96
materials selection	
recommendations .....	186(T)
quenching conditions .....	37
total case depth estimation .....	59(F)
<b>Internal ring gear of a star epicyclic</b>	
<b>gearbox</b> , ion plasma nitriding case	
history .....	163–169(F)
<b>Involute charts</b> , ring gear in ion nitriding	
case study .....	163, 165, 166(F), 168(F)
<b>Involute profiles of sun pinion teeth</b>	
after nitriding .....	149, 151(F)
before nitriding .....	149(F)
<b>Ion plasma nitriding</b> .....	159–169(F,T)
advantages over conventional gas	
nitriding .....	159–160
atmosphere .....	159, 160
case depth .....	161, 162(F)
case depth vs. process time .....	161, 162(F)
case history: internal ring gear of	
epicyclic gearbox .....	163–169(F)
cleanliness of gears .....	160
diffusion depth growth .....	161
diffusion zone .....	160
distortion reduced .....	161
hardness and case depth .....	161(T)
masking for selective nitriding .....	160–161
materials for .....	160
nitriding potential independent of	
temperature .....	161
process description .....	159
surface roughness .....	160
time duration of treatment .....	161, 162(F)
white layer .....	160
<b>Iron</b>	
crystal structure .....	5, 6(F)
freezing point .....	7, 8
melting point .....	5, 6(F)
pure .....	7(F), 8
pure, cooling curve, idealized .....	5, 6(F)
<b>Iron carbide</b> , as precipitate .....	34
<b>Iron-carbon alloys</b> , high-purity, carbon	
influence on start of martensite	
transformation .....	16(F)
<b>Iron-carbon phase diagram</b> .....	7(F), 8, 10
<b>Isothermal transformation</b> .....	11
<b>Isothermal transformation</b>	
<b>diagram</b> .....	11–12(F)
<b>J</b>	
<b>Jean Konntoret (JK) chart</b> , for rating	
cleanliness of steels .....	83, 84(F)
<b>Jominy curves</b> .....	50, 51(F)
<b>Jominy test</b> .....	45–46(F), 47(F), 48(F), 49(F)
for carburizing grade gear steels .....	79–80
<b>K</b>	
<b>Knoop hardness scale</b> .....	22(T)
<b>L</b>	
<b>Lapping</b> .....	1, 21
after induction hardening .....	182
full-length racks .....	32
to remove white layer off ion plasma	
nitrided gears .....	160
<b>Lead and involute charts</b> .....	129, 131
after heat treatment .....	131(F)
before heat treatment .....	130(F)
<b>Lead charts</b> , ring gear in ion nitriding	
case study .....	163, 165, 166(F), 168(F)
<b>Lead errors</b> .....	30, 32(T)
<b>Lead profile of sun pinion teeth</b>	
after nitriding .....	149, 151(F)
before nitriding .....	148, 149(F)
<b>Liquid-abrasive blasting</b> , prior to	
nitriding .....	141
<b>Liquid/air heat exchangers</b> .....	125
<b>Liquid carburizing</b> .....	33
<b>Liquidus curve</b> .....	7
<b>Load fluctuation</b> , as cause of nitrided	
gear failure .....	156–157, 158(F)
<b>Lot verification</b> .....	86
<b>Low-alloy steels</b> .....	39
case and core hardnesses recommended	
at gear pitch line .....	60(T)
maximum bending fatigue strength .....	64
total case depth recommendations for	
gears .....	59–60(T)
<b>Low-carbon steels</b>	
carburizing and hardening .....	33
proportionality factor for gas	
carburizing .....	35
<b>Lowest point of single-tooth contact</b>	
(LPSTC) .....	55, 56(F)

## M

- Machinability**, annealing after  
normalizing to obtain proper  
hardness ..... 87(F)
- Macroetch examination**, for heat  
verification ..... 86
- Magnetic particle inspection**  
for comparing cleanliness of  
vacuum-melted and air-melted  
steels ..... 83  
rating for heat verification ..... 86  
to check for cracks ..... 92
- Magnetic transition** ..... 5, 6(F)
- Magnetic transition temperature** ..... 5, 6(F)
- Manufacturing methods**, for full-length  
racks ..... 31
- Maraging steels** ..... 29  
composition ..... 28(T)  
contraction rate ..... 30  
contraction with through hardening ... 25–26  
distortion predictable ..... 29  
distortion ratings of through-hardened  
gears ..... 26(T)  
forgings used for racks ..... 29  
through hardening effect on Brinell  
hardness range ..... 23(T)
- Marine applications**, propulsion gears ..... 27
- Martensite** ..... 11(F), 13  
and critical cooling rate ..... 14  
crystal structure ..... 13  
effect on crack formation in the case ..... 73  
and heat treat distortion ..... 77  
in carburized cases ..... 68  
transformation to bainite ..... 13
- Martensite finish ( $M_f$ ) temperature** ... 13, 14
- Martensite start ( $M_s$ ) temperature** ... 13, 14
- Martensitic stainless steels**, induction  
hardening ..... 176
- Martensitic steel structure** ..... 8
- Martensitic transformation**, degree of  
reluctance to transform at a given  
temperature ..... 43–44
- Masking**, of gears before nitriding ..... 134
- Material**, for nitrided gears ..... 141(T)
- Material cleanliness** ..... 86  
and heat treat distortion ..... 78–81(T)
- Materials selection**  
and cost of gears ..... 185–186(T)  
product form effect on costs ..... 186(T)
- Materials standardization**, benefits ..... 186
- Maximum contact load** ..... 56
- Maximum contact stress** ..... 60
- Maximum shear stress** ..... 55, 56,  
57(F), 58–59
- Maximum shear stress theory** ..... 59
- Maximum tensile stress**, location on  
tooth ..... 62
- Mechanical working**, normalizing and  
annealing to reduce metallurgical  
nonuniformity from ..... 23
- Melting point** ..... 5, 6(F)
- Metallographic examination**, to measure  
retained austenite in carburized case ... 76
- Metallographic standards**  
for carburized, hardened, and tempered  
cases of gears ..... 70(F)  
for carburized, hardened, and tempered  
core structure ..... 72(F)  
for case carbides in carburized,  
hardened and tempered cases .... 71(F)  
for nitrided core structure ... 142(F), 143(F)
- Methane**, for endothermic gas  
production ..... 34
- Microcleanliness ratings (ASTM A  
534)**, for carburizing grade gear  
steels ..... 80
- Microcracking**  
after carburizing and hardening .. 98–100(F)  
and grind burns ..... 109, 111  
subsurface, and tempering prior to cold  
treating ..... 76
- Microexamination**, for comparing  
cleanliness of vacuum-melted and  
air-melted steels ..... 83
- Microhardness testing**  
failed nitrided gear ..... 155, 157(F)  
nitriding steels ..... 136  
nitriding steels (ion nitriding) ... 163, 164(F)  
of surface below the grind burnt area ... 109
- Microinclusion rating**, for heat  
verification ..... 86
- Microstructure**  
affected by deeper case ..... 108  
of carburized and hardened gear, case  
study ..... 126(F)  
of carburized cases ..... 68  
effect of cooling rate ..... 17  
of failed nitrided gear ..... 156  
of induction-hardened materials ..... 181  
of nitrided gears ..... 141(T), 142(F)  
requirements for different classes of  
carburized and hardened  
gears ..... 68, 69(T)
- Milling**, full-length racks ..... 31
- Miner's Rule** ..... 142
- Misalignment**, resulting from pressure  
angle increase ..... 69, 74(F)
- Molybdenum**  
content effect in nitriding steels ..... 147  
content effect on gear hardness and  
hardenability ..... 49  
content effect on temper brittleness ..... 24
- Molybdenum nitrides** ..... 133

## N

- Natural gas**, for endothermic gas
  - production ..... 34
- Nickel**
  - content effect on austenite
    - retention ..... 68, 70–72, 75(F)
  - content effect on gear hardness and hardenability ..... 48–49
- Nickel plating**, to mask gears for gas nitriding ..... 134
- Nital etch** ..... 126(F)
  - for nitriding steels ..... 136
  - to inspect gear burns ..... 109–110(F)
- Nitreg process** ..... 133
- Nitridability**, coefficient of ..... 165
- Nitrided gears.** *See also* Nitriding;  
Nitriding steels.
  - bending-fatigue life ..... 143–144, 145(F)
  - failure, case history ..... 152–158(F)
  - fatigue strength ..... 142–144(F)
  - pitch diameter and diametral pitch as parameters ..... 146
  - small diametral pitch vs. large diametral pitch ..... 144
  - steady load vs. shock loads ..... 152
- Nitrides**, effect on hardenability ..... 47, 48
- Nitriding** *See also* Nitrided gears;  
Nitriding steels.
  - steels. .... 2, 3, 18, 19, 133–158(F,T)
  - advantages and disadvantages ..... 2, 133
  - as alternative to carburizing for lightly loaded gears ..... 148
  - applications ..... 133
  - atmosphere for ..... 133
  - case depth ..... 134–135
  - case depth tolerance, costs incurred in design ..... 187(T)
  - case depth vs. process time ..... 161, 162(F)
  - case history ..... 148–152(F)
  - computer-controlled ..... 133
  - controlled nitride process ..... 165–167
  - cost ..... 145, 146(T)
  - cycle times longer ..... 134
  - distortion due to ..... 3
  - double-stage gas, cycles of ..... 138(T)
  - effective case depth of gears ..... 136
  - effect on wear life ..... 139–140
  - gas, process ..... 133–137(F,T)
  - gas, single-stage ..... 146
  - gas, two-stage process ..... 137
  - guidelines for gears ..... 140–141
  - hardness ..... 141(T)
  - heat treat distortion ..... 145–147(T)
  - ion plasma ..... 133, 159–169(F,T)
  - limitations ..... 133
  - manufacturing processes used for sun pinion ..... 148–149
  - material ..... 141(T)
  - materials recommended, low-case and deep-case ..... 186(T)
  - prenitriding requirements ..... 134
  - selective ..... 133, 146
  - selective ion ..... 160–161
  - temperature range ..... 134
  - tip and edge radii of teeth, recommendations ..... 137(T)
  - vs. quench and temper process ..... 24
  - white layer in nitrided gears ..... 137–140(F,T)
- Nitriding potential**, in controlled nitride process ..... 165–166
- Nitriding steels.** *See also* Nitrided gears;  
Nitriding.
  - alloying elements effect ..... 140
  - AMS quality ..... 163(T)
  - applications ..... 147–148
  - case crushing resistance ..... 140
  - case depth and cost factor ..... 145, 146(T)
  - case depth (ion nitriding) ..... 161(T)
  - case depth tolerance and cost factor .... 145, 146(T)
  - case depth vs. square root of ion-nitriding time ..... 161, 162(F)
  - case depth vs. treatment time ..... 161, 162(F)
  - case hardness (ion nitriding) ..... 163(T)
  - compositions for gears ..... 134(T)
  - core hardness (ion nitriding) ..... 160(T), 161(T), 163(T)
  - European ..... 147
  - European vs. U.S. compositions ..... 147
  - grain size (ion nitriding ) ..... 161(T)
  - heat treat distortion rating (ion nitriding) ..... 163(T)
  - mechanical properties ..... 137(T)
  - mechanical properties (ion nitriding) .... 163
  - microhardness traverses ..... 163, 164(F)
  - microstructure ..... 141(T), 142
  - nitriding temperature (ion nitriding) ..... 160(T), 163(T)
  - ring gear of epicyclic gearbox, ion plasma nitriding case study ..... 163–169(F)
  - surface coverage and cost factor ..... 145, 146(T)
  - surface hardness ..... 136–137(T)
  - surface hardness (ion nitriding) ..... 160(T), 161(T)
  - total case depth ..... 136
  - total case depth (ion nitriding) ..... 160(T)

- white layer composition (ion nitriding) ..... 160(T)
- white layer depth (ion nitriding) ..... 161(T)
- white layer thickness (ion nitriding) ..... 160(T)
- Nitrogen**
  - as addition to carbonitriding
    - atmosphere ..... 171
    - in nitriding atmosphere ..... 133
    - liquid, for chilling gears ..... 44
- Nitrogen-methanol furnace atmosphere system** ..... 34, 125, 127, 132
- Nonmetallic inclusions**
  - effect on fatigue strength of metal ..... 83, 84(F), 85
  - effect on hardenability ..... 47, 48
  - effect on mechanical properties ..... 78
  - in carburizing grade gear steels ..... 80
  - in European nitriding steels ..... 147
- Normalizing** ..... 22–23(T), 132
  - before induction hardening ..... 176
  - definition ..... 22–23
  - optimum temperature range ..... 86
  - prior to nitriding ..... 134
  - procedure, typical ..... 88
  - of ring gear in ion nitriding study,
    - distortion resulting ..... 165, 169(F)
    - to eliminate banding ..... 84
    - to minimize distortion ..... 86
    - to refine grain structure ..... 88
- Normalizing and annealing** ..... 22–23(T)
- Normalizing and tempering** ..... 23(T)
- “Nose” of S-curve** ..... 12
- Number of cycles to failure, of nitrided gears** ..... 142
- O**
- Out of roundness of gear pitch diameter** ..... 128, 130(F)
- Overt tempering, of gear tooth** ..... 111, 113(F), 114(F), 115(F)
- Oxide scale, prevention of** ..... 38
- P**
- Pack carburizing** ..... 33, 39
- Pearlite** ..... 8, 9, 11(F)
  - as final product after cooling ..... 13
  - fine ..... 10, 11, 12
  - in carburized and hardened gear microstructure ..... 126(F)
  - in carburized cases ..... 68
- Pearlite point** ..... 8
- Peen scan process** ..... 117
- Phase diagrams**
  - for carbon steels ..... 9(F)
  - iron-carbon ..... 7(F), 8, 10
- Pinion pitch diameter** ..... 60
- Pitch** ..... 30
- Pitch diameter (PD) runouts** ..... 100, 101–102
- Pitch errors** ..... 30
- Pitch line** ..... 56(F), 58, 59(F)
- Pitch line runouts** ..... 130–131
- Pitch line velocity** ..... 26, 97
- Pitch point** ..... 55–56(F), 59(F)
- Pitting** ..... 1, 55
- Pitting fatigue life**
  - of nitrided gears ..... 142
  - and shot peening ..... 114
- Pitting fatigue strength, vs. grain size** ..... 65–66
- Pitting life** ..... 53, 59
  - at any allowable contact stress that corresponds to a specific tooth
    - hardness ..... 106
    - equation in terms of stress cycles ..... 105
    - and honing and grinding ..... 112
    - minimum value for gears ..... 101
    - new ..... 105–107(F,T)
    - reduced by low surface hardness ..... 44
    - and retained austenite content ..... 73
    - and shot peening ..... 112, 114
    - and through hardening ..... 26
- Planet gears** ..... 153(F), 157, 158
- Plate covers, to mask gears for selective ion nitriding** ..... 160–161
- Plating, to prevent carbon penetration through tooth tip** ..... 33
- Poisson’s ratio** ..... 56
- Polishing** ..... 53
- Precipitation-hardening steels** ..... 28–29(T)
  - composition ..... 28(T)
- Preheating, of gears** ..... 90
- Preheating furnace** ..... 17
- Pre-heat-treat gear-cutting tools, modification to accommodate distortion** ..... 2, 3
- Pre-heat treatment, for induction hardening** ..... 176
- Pressure angle** ..... 60
  - effect on case depth during carburizing ..... 69
- Proeutectoid ferrite** ..... 68
- Profile conformance, to increase scuffing resistance** ..... 26
- Pure rolling** ..... 55–56



## Q

<b>Quality</b>	
of nitrided gear teeth .....	148
of steel, and heat treat distortion after carburizing and hardening .....	77–78
<b>Quench and tempered pretreatment,</b> for induction hardening .....	176
<b>Quench and temper process</b> .....	23–24(T)
effect on Brinell hardness range of gears .....	23(T), 24
power transmission applications .....	26
<b>Quenchant flow,</b> effect on heat treat distortion .....	81
<b>Quenchant speed,</b> effect on heat treat distortion .....	81
<b>Quenchant temperature,</b> effect on heat treat distortion .....	81
<b>Quench-hardening steels</b> .....	28–29(T)
composition .....	28(T)
<b>Quenching</b>	
after carburizing .....	37
after gas carburizing .....	35
after induction hardening .....	175, 176, 178
agitation rate .....	40
ausbay quenching .....	90
differential heat transfer rate .....	96
direct .....	38–39
hanging gears from fixturing rods ...	100(F)
press quench .....	88
and reheating of carburized gears ...	39–40
step quenching .....	90
surface hardness variations after .....	40
temperature, effect on retained austenite .....	73
<b>Quenching method,</b> effect on heat treat distortion .....	81
<b>Quench system,</b> for carburizing and hardening case study .....	125, 131

## R

<b>Rack</b>	
design and manufacture of .....	27–32(F,T)
furnaces for heat treatment .....	29
heat treating procedure .....	30–32(T)
manufacturing method for full-length racks .....	31
material selection .....	27–29(T)
<b>Rail industry applications,</b> railway power transmission gears .....	27
<b>Recarburizing</b> .....	42–43
<b>Reduction of area</b>	
carburizing grade gear steels ...	52(T), 85(T)
nitriding steels .....	137(T)

<b>References</b> .....	189–192
<b>Reheating,</b> after high-temperature carburizing .....	40
<b>Reishauer gear grinder</b> .....	110
<b>Residual compressive stress</b>	
of dual-frequency process induction hardening .....	183(F)
effect on cold treatment transformation result .....	76
<b>Residual stresses</b> .....	57, 76, 179, 183(F)
of shot peening .....	118, 120(F,T)
surface .....	58
<b>Residual tensile stress,</b> in induction hardening .....	179
<b>Retained austenite</b> .....	15
carbon potential effect .....	73
cold treatment effect .....	73–76
cooling rate effect .....	73
desirable level for gear teeth .....	50–51
disintegration with ion plasma nitriding .....	161
effect on bending fatigue strength .....	72, 75(F)
effect on gear performance, as carburizing problem .....	70–76(F)
effect on tooth surface hardness .....	103
effect on volume after hardening .....	77
excessive after recarburizing .....	43
and grind burn .....	108
and grind burn inspection .....	111
and hardening .....	37, 39
in carburized cases .....	68
in case microstructure .....	43
increased with deeper case .....	108
in reheated gears .....	40
measurement methods .....	76
metallographic standards for carburized, hardened, and tempered cases .....	70(F)
quench temperature effect .....	73
stabilized by tempering .....	76
subzero treatment effect .....	75
<b>Ring gear</b>	
dimensions .....	163, 165(F)
ion plasma nitriding case history .....	163–169(F)
<b>Rockwell hardness scale</b> .....	21, 22(T)
<b>Rockwell superficial hardness testing,</b> of overtempered areas (ASTM E 18) .....	111

## S

<b>Sandblasting,</b> to remove white layer .....	138
--	-----

- Scanning electron microscope**, to  
examine nitrided gear tooth  
failure ..... 154, 155(F), 156(F)
- Scoring life**, of gears ..... 152
- Scuffing**, of gears ..... 26
- S-curve** ..... 11, 12(F), 13  
and continuous cooling curves ..... 13, 14(F)  
and critical cooling rate ..... 14–15
- Section size**, effect on core hardness and  
tensile properties of carburized  
steels ..... 52(T)
- Section thickness**, and cooling rate ..... 17
- Selection of heat treat process for  
optimum gear design** ..... 185–188(T)
- Service life**, retained austenite controlled  
for maximum value ..... 73
- Shaper cutters** ..... 2  
development to include modification  
for contraction rate ..... 30, 31(F)  
to cut gear teeth in maraging steel  
forgings ..... 29
- Shear stress theory** ..... 58
- Shot peening**  
angle of shot impingement ..... 118  
of carburized and hardened  
gears ..... 111–121(F,T)  
coverage ..... 117–118, 120(T)  
intensity ..... 115, 116–117, 120(T)  
microprocessor-controlled ..... 118  
not required for nitrided gears ..... 141  
parameters recommended . 118, 119–120(T)  
principle of ..... 113, 117(F)  
residual stress ..... 118, 120(F,T)  
size of shot used ..... 115, 120(T)  
specifications ..... 119  
stress profile of carburized gear tooth  
root ground ..... 113, 118(F)  
tooth surface profile ..... 119, 121(F)  
type of shot used ..... 114–115, 120(T)
- Silica-type inclusions** ..... 84(F)
- Single case**, vs. carburizing cost ..... 123(T)
- Skin effect** ..... 175
- Slack-quenched steel** ..... 14
- Sliding** ..... 56
- S-N curve**, for nitrided  
gears ..... 142, 144(F), 157
- Solid carburizing** ..... 33
- Solidus curve** ..... 7
- Spalling** ..... 134
- Spheroidization** ..... 8
- Split transformation** ..... 11
- Spraying**, to prevent carbon penetration  
through tooth tip ..... 33
- Spur gears** ..... 100
- Star epicyclic gearbox**, internal ring gear  
case history, ion plasma  
nitriding ..... 163–169(F)
- Steels**  
deep-hardening ..... 46  
distortion ratings of through-hardened  
gears ..... 26(T)  
H-band ..... 46  
slack-quenched ..... 14  
surface hardness variation with  
tempering temperature of gears ..... 41  
through hardening effect on Brinell  
hardness range ..... 23(T)
- Step grinding** ..... 53
- Stock allowance** ..... 25
- Stress**, microcracking due to ..... 98
- Stress relief**  
before ion plasma nitriding ..... 163  
of gears before heat treatment ..... 78  
in normalizing procedure ..... 88
- Subzero treatment**, effect on retained  
austenite ..... 75
- Sulfide-type inclusions** ..... 84(F)
- Sulphur**, effect on machinability of AMS  
2300 steels ..... 78
- Sun pinion**, basic  
dimensions ..... 148, 150(F), 158
- Surface compressive stress** ..... 108  
after shot peening ..... 113
- Surface coverage**  
cost factors for nitriding steels ..... 145,  
145(T)  
and costs in design ..... 187(T)  
vs. carburizing cost ..... 123(T)
- Surface hardening** ..... 1
- Surface hardness**  
and actual stock removal, carburizing  
and hardening ..... 103–105(F)  
after grinding ..... 101  
during nitriding ..... 149–150  
and grind burn ..... 108  
induction-hardened materials . 178–180(F,T)  
of nitriding steels ..... 136–137(T)  
nitriding steels (ion nitriding) ..... 161(T)  
variations after quenching ..... 40  
variations with tempering  
temperature ..... 41(F)  
vs. case depth ..... 95, 96(F)  
of webbed gears ..... 95–96(F)
- Surface oxidation**  
during carburizing ..... 64  
metallographic standard for carburized,  
hardened and tempered cases ..... 70(F)
- T**
- Temperature**  
ambient ..... 36  
carburizing ..... 36

<b>Temperature (continued)</b>	
vs. grain size, carburized steels .....	66
<b>Temperature gradient</b> .....	77
<b>Temper brittleness</b> .....	24
<b>Tempered martensite</b>	
in nitrided gear microstructure .....	142(F)
microstructure of ring gear in ion nitriding study .....	165
<b>Temper etch method</b> , to inspect gear burns .....	109–110
<b>Tempering</b> .....	23–24(T)
after induction hardening .....	178
of carburized and hardened gears in case study .....	127
of carburized and quenched gears .....	40–42(F)
chromium content effect .....	49
as intermediate thermal treatment with cold treatment .....	76
metallographic standard .....	70(F)
metallographic standard for case carbides .....	71(F)
metallographic standards for core structure .....	72(F)
prior to cold treating .....	76
prior to nitriding .....	134
stabilizing retained austenite .....	76
temperature effect on core hardness of high alloy steels .....	42(F)
temperature range specification in drawing .....	25
temperature recommended for carburized and quenched gears .....	41
temperature variation with surface hardness .....	41(F)
timeliness effect on distortion .....	41
<b>Tempering embrittlement</b> .....	24
<b>Tempering temperature</b> , of carburizing grade gear steels .....	85(T)
<b>Tensile strength</b>	
of carburizing grade gear steels .....	52(T), 85(T)
nitriding steels .....	137(T)
<b>Tensile stress</b> , of nitrided gears .....	144
<b>Test bars</b> .....	90
<b>Tests</b> , of carburized forgings for distortion control .....	125–126(T)
<b>Thermal shock</b> .....	36, 39
in quench system of carburizing case study .....	125
microcracking due to .....	98
<b>Thermal stress</b> , after carburizing and hardening .....	77
<b>Thermocouple</b> , failure, effect on carburizing process .....	89, 90
<b>Thread chasing</b> .....	97–98
<b>Through hardening</b> .....	2, 3, 18, 22–32(F,T)
distortion from heat treating of gears .....	25–26
distortion of gears .....	25–26(T), 27
expansion due to heat treating .....	25–26
gear design guidelines .....	24–25
gear material guidelines .....	24–25
hardness measurement .....	25
limitations of gears .....	26
materials recommended .....	186(T)
use reduced on gears in last decade .....	3
vs. case hardening .....	188
<b>Time, temperature, and transformation (TTT) diagram</b> .....	11, 12(F)
<b>Tooth perpendicularity (lead error)</b> .....	30, 32(T)
<b>Tooth ratio</b> .....	60
<b>Torque-carrying capacity</b> .....	2
<b>Total case depth</b> .....	52, 58–59(F)
of nitriding steels .....	136
recommended for low-alloy steel gears .....	59–60(T)
<b>Toughness</b> , improved by tempering .....	23
<b>Transformation stress</b> , after carburizing and hardening .....	77
<b>Transformation temperature</b> .....	9–10
<b>Transgranular fatigue crack propagation</b> .....	154, 156(F)
<b>Triaxial tensile stress</b> .....	56
<b>TTT diagram</b> .....	11, 12(F)
<b>Tukon (Knoop) hardness scale</b> .....	22(T)
<b>Tukon type microhardness tester</b> .....	53
<b>Tungsten</b> , content effect on gear hardness and hardenability .....	50
<b>V</b>	
<b>Vacuum arc remelt (VAR) steels</b>	
Aerospace Material Specification 2300, highest cleanliness standard .....	78
Aerospace Material Specification 2304 quality steel, nonmetallic inclusions under strict control .....	78
benefits .....	82
costs .....	83–85(F)
distortion derating factors .....	107(T)
load carrying capacity .....	85
<b>Vacuum carburizing</b> .....	37
<b>Vacuum fusion technique</b> .....	82(T)
<b>Vanadium</b>	
content effect in nitriding steels .....	147
content effect on gear hardness and hardenability .....	49–50
<b>Vanadium nitrides</b> .....	133

<b>Vickers hardness scale</b> .....	21, 22(T)	produced during nitriding .....	152
<b>Volume</b> , change with heat treat distortion		two-stage process vs. one-stage	
of gears .....	77	process .....	140
<b>Volumetric expansion</b> , coefficient of .....	77		

## W

<b>Wear</b> , of gear teeth .....	1
<b>Wear life</b> , of nitrided gears .....	139–140
<b>Webbed construction</b> .....	81, 82(F)
<b>Webbed gear teeth</b> .....	95(F)
<b>White layer</b> .....	137–140(F,T)
depth, in nitriding steels (ion	
nitriding) .....	161(T)
depth, ring gear in ion nitriding case	
study .....	165, 167(F)
in controlled nitride process .....	166
of ion plasma nitriding .....	160

## X

<b>X-ray diffraction</b> , to measure retained	
austenite in carburized	
case .....	76

## Y

<b>Yield point</b> , of nitriding steels .....	137(T)
<b>Yield strength</b> , of carburizing grade gear	
steels .....	52(T), 85(T)



The Materials  
Information Society

**ASM International** is the society for materials engineers and scientists, a worldwide network dedicated to advancing industry, technology, and applications of metals and materials.

ASM International, Materials Park, Ohio, USA  
www.asminternational.org

This publication is copyright © ASM International®. All rights reserved.

Publication title	Product code
<b>Heat Treatment of Gears: A Practical Guide for Engineers</b>	<b>#06732G</b>

**To order products from ASM International:**

**Online** Visit [www.asminternational.org/bookstore](http://www.asminternational.org/bookstore)

**Telephone** 1-800-336-5152 (US) or 1-440-338-5151 (Outside US)

**Fax** 1-440-338-4634

**Mail** Customer Service, ASM International  
9639 Kinsman Rd, Materials Park, Ohio 44073-0002, USA

**Email** [CustomerService@asminternational.org](mailto:CustomerService@asminternational.org)

**In Europe** American Technical Publishers Ltd.  
27-29 Knowl Piece, Wilbury Way, Hitchin Hertfordshire SG4 0SX,  
United Kingdom  
Telephone: 01462 437933 (account holders), 01462 431525 (credit card)  
[www.ameritech.co.uk](http://www.ameritech.co.uk)

**In Japan** Neutrino Inc.  
Takahashi Bldg., 44-3 Fuda 1-chome, Chofu-Shi, Tokyo 182 Japan  
Telephone: 81 (0) 424 84 5550

**Terms of Use.** This publication is being made available in PDF format as a benefit to members and customers of ASM International. You may download and print a copy of this publication for your personal use only. Other use and distribution is prohibited without the express written permission of ASM International.

No warranties, express or implied, including, without limitation, warranties of merchantability or fitness for a particular purpose, are given in connection with this publication. Although this information is believed to be accurate by ASM, ASM cannot guarantee that favorable results will be obtained from the use of this publication alone. This publication is intended for use by persons having technical skill, at their sole discretion and risk. Since the conditions of product or material use are outside of ASM's control, ASM assumes no liability or obligation in connection with any use of this information. As with any material, evaluation of the material under end-use conditions prior to specification is essential. Therefore, specific testing under actual conditions is recommended.

Nothing contained in this publication shall be construed as a grant of any right of manufacture, sale, use, or reproduction, in connection with any method, process, apparatus, product, composition, or system, whether or not covered by letters patent, copyright, or trademark, and nothing contained in this publication shall be construed as a defense against any alleged infringement of letters patent, copyright, or trademark, or as a defense against liability for such infringement.